

1
2
W X

國立臺灣大學圖書館



2 2 3 8 2 2 7

613237536
(2002)

**2002
NATIONAL DEFENSE
REPORT**
REPUBLIC OF CHINA

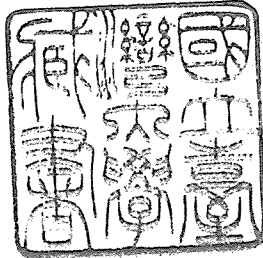

2238227

2002 NATIONAL DEFENSE REPORT

REPUBLIC OF CHINA

Translated by

Alice Y. F. Hsu, Fang Shu-hui, Hsiao Kuang-pei, Hsieh Kai-ti,
Lee Chun-chung, Lin Ju-yu, Lin Pei-jung, Joyce Cheng,
Su Tzi-yao, Wu Szu-chi, Ying Chung-hu, Yu Chia-ling

Revised by

Chen Ching-jenn, Chiang Hsi-ming, Hsiao Kuang-pei, Lin Min,
Liu Ching-shuen, Liu Lee-hsuan, Yeh An-sheng

Proofread by

Hsiao Kuang-pei, Huang Guo-shang, Huang Shu-fen,
Sun Wen-chi, Sung Chia-chu, Wu Chern-huei

Special Thanks to

Ph. D. Andrew Yang, Secretary General, CAPS

Composed by

Chang Chin-long

Copyright (c) 2002 by:

Military History & Translation Office, Ministry of National Defense
807 Pei-an Road, Taipei, Taiwan, ROC

All rights reserved

Printed in Taipei, Taiwan, ROC

July, 2002

GPN: 004013890217

ISBN: 957-02-6288-5 (Hard Cover)

957-02-6289-3 (Soft Cover)

Price: NT\$ 500 (Hard Cover) NT\$ 450 (Soft Cover)

Contents

IX • Preface

XIII • Introduction

XVI • Prologue

Part 1 International Security Environment and Military Situation

1 Summary

3 Chapter 1 International Security Environment

3 I. Security Challenges

4 II. Peacekeeping Efforts

5 III. Potential Threats

9 Chapter 2 Global Military Situation

9 I. General Military Situation

11 II. Regional Military Situation

13 Chapter 3 Military Situation in Asia

13 I. U.S. Security Strategy Toward Asia

14 II. Military Development in Asian Countries

23 III. Implication of Asia's Military Situation for the ROC

25 Chapter 4 Military Situation in the PRC

25 I. Strategic Environment

30 II. Military Strategy

33 III. Current Force

38 IV. National Defense Mobilization

38 V. Defense Budget

40 VI. Military Development

44 VII. Military Exercises

45 VIII. Military Diplomacy and Cooperation

46 IX. Implication of the PRC's Military Situation for the Asia-Pacific
Region and the ROC

18 Table 1-1 Current Military Strengths of Southeast Asian Nations

40 Table 1-2 Defense Expenditure of the PRC in the Last Decade

20 Figure 1-1 The Current Situation of the Spratley Islands

33 Figure 1-2 Estimated Armed Forces Strength Ratio of the PRC

34 Figure 1-3 Estimated Ground Forces Deployment of PLA

39 Figure 1-4 Statistics of the PRC Defense Budget from 1992 to 2001

Part 2 National Security and Defense Policy

49 Summary

51 Chapter 1 Overview of Security Situation

51 I. Security Environment

52 II. Analysis on the Situation of National Security

59 Chapter 2 National Security Strategy

59 I. Significance of National Security Strategy

59 II. Factors Involved in the Making of National Security Strategy

61 III. Conceptual Framework of National Security Strategy

63 Chapter 3 National Security Policy

67 Chapter 4 National Defense Policy and Military Strategy

67 I. Objectives of National Defense

67 II. Fundamental Concepts of National Defense

68 III. Implementation Guideline of the National Defense Policies

71 IV. Military Strategies

75 V. Organizational Structure

79 Chapter 5 Objectives for Force Restructuring

78 Table 2-1 Organizational Chart of Ministry of National Defense

60 Figure 2-1 The System of National Security Strategies

Part 3 National Defense Resources

85 Summary

87 Chapter 1 National Defense Manpower

87 I. Policy and Objectives

87 II. Quality and Age Structure of Servicemen

90 III. Recruitment

91 IV. Vision

93 Chapter 2 National Defense Funding

93 I. Objectives and Policies

94 II. Acquisition and Planning of National Defense Budgets

97 III. Allotment and Utilization of National Defense Budget

104 IV. Management and Supervision of National Defense Budget

104	V. Vision
107	Chapter 3 National Defense Material
107	I. National Defense Technology Industries
116	II. Acquisition of Weapons
122	III. Land for National Defense Usage
123	IV. Vision
91	Table 3-1 Enrollment Statistic Data from 1999 to 2001
88	Figure 3-1 Percentage Comparison of Different Servicemen, 2000
89	Figure 3-2 Education Status Analysis of the Armed Forces, 2001
89	Figure 3-3 Average Age Comparison of the ROC Armed Forces, 1999-2001
94	Figure 3-4 The Proportion of Defense Budget in Total Government Budget and GNP, FY1993-2002
95	Figure 3-5 Comparison of the Growth of Total Central Government Budget and Defense Budget, FY 1993-2002
96	Figure 3-6 The Ratio of Unclassified and Classified Defense Budget, FY 1993-2002
98	Figure 3-7 Budget Items of National Defense Budget in FY 2001
99	Figure 3-8 Defense Budget Sharing Structure by Component, FY 2001
100	Figure 3-9 Structure of Military Investment of National Defense Budget, FY 2001
101	Figure 3-10 Budget Items of National Defense Budget, FY 2002
102	Figure 3-11 Defense Budget Sharing Structure by Component, FY 2002
103	Figure 3-12 Categories of Military Investment of National Defense Budget, FY 2002
104	Figure 3-13 Budget Execution in the Second Half of FY 1999 and FY 2000
105	Figure 3-14 Budget Execution in FY 2001
120	Figure 3-15 The Procurement Projects in FY2001

Part 4 ROC Armed Forces

125	Summary
127	Chapter 1 Regular Forces
127	I. Army
128	II. Navy
130	III. Air Force
131	IV. Military Police
132	V. Electronic and Information Warfare Forces
134	VI. Vision
139	Chapter 2 Reserves

139	I. Army Reserves
139	II. Navy Reserves
140	III. Air Force Reserves
140	IV. Reserve Units of the Combined Logistics Command
141	V. Reserve Units of the Reserve Command
141	VI. Reserve Units of the Military Police Command
142	VII. Vision
143	Chapter 3 Logistic Support Forces
143	I. Combined Logistics Command
144	II. Reserve Command
146	III. Vision
Part 5 National Defense Management	
149	Summary
151	Chapter 1 Management of National Defense Human Resources
151	I. Objectives
151	II. Current Policies and Implementation Status
160	III. Vision
163	Chapter 2 Management of National Defense Regulations
163	I. Objectives and Policies
163	II. Implementation Status
169	III. Vision
171	Chapter 3 Management of National Defense Expenditures
171	I. Objectives and Policies
172	II. Implementation Status
174	III. Vision
175	Chapter 4 Management of Military Mobilization
175	I. Mobilization of the ROC Armed Forces
177	II. Mobilization of Military Supply Industries
178	III. Mobilization of Military Transportation
179	IV. Requisition of Required Military Materials
180	V. Mobilization for Assisting in Military Services
181	VI. Coordination Conferences for All-out Combat Capabilities

182	VII. Mobilization Exercises and Trainings
183	VIII. Improvements in Reserve Mobilization
185	IX. Vision
187	Chapter 5 Management of Logistics
187	I. Objectives and Policies
189	II. Implementation Status
199	III. Vision
201	Chapter 6 Management of Forces
201	I. Objectives
201	II. Implementation Status
212	III. Vision
215	Chapter 7 Management of Communications & Electronic Information
215	I. Objectives and Policies
215	II. Emphasis and Implementation Status
219	III. Vision
164	Table 5-1 Regulations and Rules Enacted from 2000 to 2002
165	Table 5-2 Regulations and Rules Amended from 2000 to 2002
166	Table 5-3 Laws and Regulations Abolished from 2000 to 2002
173	Table 5-4 Amended Regulations for Accounting Management of Defense Expenditures
213	Table 5-5 The List of "0800" Toll Free Numbers of the MND and Various Units for Consulting and Appealing
Part 6 Important National Defense Policy Implementation	
221	Summary
223	Chapter 1 Position and Mission of the ROC Armed Forces
223	I. Nationalization of the ROC Armed Forces
224	II. Position and Mission of the ROC Armed Forces
224	III. Loyalty, Unity, and Best Performance in Military Duties
225	IV. Vision
227	Chapter 2 Restructuring of National Defense Organization
227	I. Origin
228	II. Planning Concept
230	III. Overview of Highlights of the National Defense Law & the Organization

Law of the Ministry of National Defense

- 232 IV. Intended Results
- 235 V. Vision
- 237 Chapter 3 Implementation of All-out Defense**
- 237 I. Objectives
- 237 II. Implementation Status
- 239 III. Mobilization of All-out Defense
- 243 IV. Vision
- 245 Chapter 4 Military Education**
- 245** I. Objectives
- 245 II. Policy
- 250 III. Features of Military Professional Education
- 253 IV. Vision
- 255 Chapter 5 Training of the ROC Armed Forces**
- 255** I. Operational Exercises and Trainings
- 255 II. Verification of Results of Physical & Combat Trainings
- 259 III. Reconstruction of Training Bases
- 261 IV. Vision
- 263 Chapter 6 Military Exchange**
- 263** I. Military Exchange and Cooperation
- 263 II. Study of Cross-Strait Military Mutual Confidence Mechanism
- 267 III. Vision
- 269 Chapter 7 Accomplishments and Prospects of National Defense Technology**
- 269** I. Electronic Warfare System
- 273 II. Information Warfare System
- 274 III. Major Weapon Systems
- 277 IV. Key Know-how of National Defense Technology
- 279 V. Military-civilian Dual-use Technology
- 284 VI. Vision
- 285 Chapter 8 Human Rights Protection for Servicemen**
- 285** I. Purposes
- 285 II. Revision of the Criminal Law for the Army, Navy, and Air Force

286	III. Revision of the Court-Martial Jurisdiction Law
286	IV. Protecting the Rights for Servicemen
287	V. Vision
289	Chapter 9 Insurance, Welfare, and Medical Care
289	I. Insurance
289	II. Welfare
292	III. Medical Care
294	IV. Vision
295	Chapter 10 Rebuilding of Military Dependent Quarters
295	I. Purposes
295	II. Policy
296	III. Implementation Status
299	IV. Vision
256	Table 6-1 Main Exercises and Training of the ROC Armed Forces in FY 2001
240	Figure 6-1 Mechanism of National Mobilization
241	Figure 6-2 Mechanism of All-out Defense Mobilization Conference
242	Figure 6-3 Directive Mechanism of All-out Defense Mobilization Program
296	Figure 6-4 Organization Charts of Authorities for Rebuilding Military Dependents' Quarters
297	Figure 6-5 Rebuilding Plan of Military Dependents' Quarters
Part 7 ROC Armed Forces and Society	
301	Summary
303	Chapter 1 Transparentization of National Defense Affairs
303	I. Objectives
304	II. Timely Explanations of Policies
305	III. Active Communication and Coordination
306	IV. Vision
309	Chapter 2 Protecting the Rights of the People
309	I. Objectives
309	II. Concrete Policies and Measures
314	III. Vision
315	Chapter 3 Providing Service to the People
315	I. Joint Efforts to Maintain Social Security

315	II. Disaster Relief and Rescue
317	III. Rescuing People in Distress
318	IV. Supporting Epidemic Prevention
320	V. Promotion of the Amity between the ROC Armed Forces and the People
324	VI. Vision
313	Table 7-1 People's Appeal Cases in 2002
317	Table 7-2 Statistics of Emergency Rescue by the ROC Armed Forces from 2000 to 2002
318	Table 7-3 Statistics of Calamity Rescue Efforts Conducted by the ROC Armed Forces from 2000 to 2002
319	Figure 7-1 The Procedure of Investigating Epidemics by the ROC Armed Forces

Preface

The essence of maintaining national security is not merely to establish a military force, but also to obtain a strong strength to defend the nation through the support and commitment from the people. Consequently, the Ministry of National Defense (MND) is dedicated itself to the transparentization of national defense affairs by publishing the National Defense Report periodically with an aim at elaborating concepts in national defense and results in policy-implementation so as to win the support from the people. It is expected that through these efforts the people may have a clear understanding on the current national defense policies, then extend their precious support to the Ministry, and participate in the national defense affairs so as to reach a comprehensive consensus on all-out defense.

The National Defense Law and the Organization Law of the Ministry of National Defense took effect on March 1, 2002. These two laws incorporate concepts like "convergence of military administration system and military command system, and civilian control of the military," which have constituted a major reform in our national defense organization. This achievement has demonstrated the resolute adherence of the ROC Armed Forces to pursue legalization in national defense affairs; furthermore, it has laid down a solid foundation for "all-out defense" and "nationalization of the ROC Armed Forces," which have imposed unprecedented influences on the military. At the juncture of the implementation of these two laws, the 2002 National Defense Report obviously is exceptionally meaningful, and it will offer an in-depth analysis on concepts and visions of the implementation of these two laws so as to show our determination to lead our national defense organs toward democratization.

During the preparation period of the Report, the United States suffered terrorist attacks on September 11, 2001; thus, the concerns over national security have once again attracted spotlights around the globe. Despite of being an abstract concept, national security efforts are aimed at assuring "national survival," which means to maintain "the security of territory, the

people and their living style," and prevent "threats of aggression." The ROC Armed Forces has been long enduring intimidations from the "verbal attacks and saber rattling" from the People's Republic of China (PRC), and our endeavor to maintain combat readiness is indeed full of challenges. Especially, the People's Liberation Army (PLA) is vigorously transforming itself under its strategic guideline of "winnig a local war under high-tech conditions," and the threat it is posing is more alarming to our national survival and development. In order to negate the increasing threats from the PRC's military satellites, technology of ballistic missile, and information warfare, the ROC Armed Forces will assume a posture of "effective deterrence, resolute defense" under the fundamental concepts of "prevention of war," "maintaining stability in the Taiwan Strait," and "defending the national soil." Besides, it will spare no efforts to follow the guideline of "preempting information & electronic superiorities, keeping hostile unlimited warfare at bay, combining operations to commmand the air and the sea, assuring safety of ground operations, and defeating intruding enemies, " to continuously strengthen its prowess in information & electronic arenas, and integrate weapon systems of the ROC Armed Forces so as to establish a "compact but delicate, highly capable" and modernized military force.

Owing to the fast development of modern technology, the nature of war has changed from converging forces to converging knowledge and technology. As a result, improving the quality of military personnel and demonstrating the efficiency of precision weapons play key roles to perform combat capabilities. Facing such directions, the ROC Armed Forces has to grasp the contemporary trends, get rid of stereotypes, and create innovative initiatives. With an eye to adapting changes in national financial structure and carrying on the modernization of national defense, the ROC Armed Forces will fine-tune its organization through "adjusting high echelon organization" and "streamlining force structure" so that it can reasonably trim its personnel expenses, and flexibly regulate military investment

and operating expenses so as to substantively enhance its combat capabilities. However, the most important facet of the force reduction efforts is to "broadly withhold reserve force." Based on "the regulations for preparation of all-out defense mobilization," the MND will promote the concept of "the combination of national defense and the people's livelihood" in the future. It is expected that through gaining cohesion from the people, the concept of "all-out defense" can be realized to establish an overall defense capability with the people's full participation. Only after maintaining superiority in "tangible combat strength" and "intangible psychological awareness" dare the enemy not rashly wage a war so that the goal of "prevention of war" can thus be achieved.

In conclusion, I would like to express my sincere appreciation to the advisors and staff members involved because the Report cannot be made public without their dedication. Besides, I shall say the diligence and the hard work that the ROC Armed Forces has shown have achieved positive results because the content of the Report cannot be enriched without its commitment to national defense. In addition, it is expected that people from all walks of life can offer comments and guidances, and render concerns and support to the national defense affairs so as to motivate the ROC Armed Forces to pursue improvements, which can provide a more solid and sound foundation for the everlasting survival and development of the Republic of China.



Tang Yiau-ming

Minister of National Defense, ROC
July 2002

2002
NATIONAL DEFENSE REPORT

Introduction

1. Following the steps of the previous five editions, the 2002 National Defense Report was circumspectly completed by the MND in accordance with the national status quo, national defense situations and policies implementation of policies. Especially, organizational changes, new defense policy concepts, courses and prospectives after the passage of the "National Defense Law" and "Organization Law of the Ministry of National Defense" are incorporated within this report. Aside from Preface, this report is divided into 7 parts - "International Security Environment and Military Situation," "National Security and Defense Policy," "National Defense Resources," "ROC Armed Forces," "National Defense Management," "Important National Defense Policy Implementation," and "ROC Armed Forces and Society." Relevant statistics and data start from July 2000 to June 2002.

Part 1. International Security Environment and Military Situation

This part provides an overview of international security environment and international military status, highlighting the threats to security, regional development status, arms transfer and proliferation, trends in the development of military technology and the change of the nature of war. Among which, the PRC's status and development of the PLA are described in detail so that the current security environment of the ROC can be clearly portrayed to be a concrete basis for defense policy-making.

Part 2. National Security and Defense Policy

From the prospective of national interests and goals, national security strategies and policies are made in accordance with analysis regarding the ROC's national security. As a major part of the report, part 2 elaborates the ROC's defense policies, military strategies, force restructuring status as well as the concept of "all-out defense."

Part 3. National Defense Resources

This part lists the available resources of manpower, material, and finance for national defense purposes, explains current policies regarding these

resources and provides analysis on the reasonable requirement of defense expenditure.

Part 4. ROC Armed Forces

This part describes the overall status of the ROC Armed Forces, including the information regarding missions, current status, organizations, major weapon systems of regular forces, logistic support units and reserves. Especially, it's the first time to incorporate electronic and information warfare units within the Report.

Part 5. National Defense Management

This part explains how the ROC Armed Forces adopts modern corporate management principles to its national defense management. In this part, human resources, regulations, expenditures, mobilization, logistics, forces, communications and electronic information are of great concerns within the domain of national defense management.

Part 6. Important National Defense Policy Implementation

This part summarizes major reforms and administrative programs of the past two years, especially those having great influence on the military reforms. In this part, information regarding restructuring of defense organizations, unit trainings, military exchanges, defense technologies and human rights for servicemen is provided in order to make the general public have a clear understanding on these programs.

Part 7. ROC Armed Forces and Society

This part serves to detail the importance of relation between Armed Forces and the society. Facing rapid social changes, the Armed Forces, following the demand for transparency, civil rights and broad civil service, maintains benign interaction with the general public.

2. At present, the interests of the ROC are as follows: assurance to national survival and development, preservation of security and social welfare, and protection of democracy and basic human rights.
3. Currently, the military development of the PRC still gives high priority to

responding to Taiwan issue and foreign interventions that may involve the two sides of the Taiwan Strait. As a result, strategies, tactics and armament developments of the PRC emphasize on obtaining electromagnetic superiority, preempting the command of the air and the sea, and conducting joint landing operations and fighting-off an aircraft carrier group. Because of its thirst to military modernization, the PRC has not only been continuously importing new armaments, but also expanding military expenditures. Therefore, the PRC indeed is posing a great threat to the ROC as time goes.

4. In order to be responsive to the international strategic environment and the PRC's military threat, the ROC's basic concepts towards current defense policy are "prevention of war," "maintaining stability in the Taiwan Strait," and "defending the national soil," while its guidelines are "enhancing all-out defense," "legalizing national defense affairs," "establishing modern national defense capabilities," "creating crisis management mechanism," "promoting regional security cooperation" and "realizing three assurances policy."
5. After the enactment of the "National Defense Law" and "Organization Law of the Ministry of National Defense," the concepts of "convergence of military administration system and military command system," "civilian control of the military" and "professional division of labor among military administration, military command and military armament systems" are thus realized. Due to the newly established defense mechanism as "responsibility corresponding with authority" and "expertises corresponding with relevant level," it's hoped that the ROC Armed Forces can fully focus on the combat trainings and readiness, thus forming a modernized and competent force.
6. Aside from transferring defense technologies into domestic private sectors so as to help form an autonomous defense force, the defense technol-

- ogy policy of the ROC will not permit obtaining, producing and fielding NBC (nuclear, biological and chemical) weapons, and will firmly follow international conventions in this regard.
7. Considering restraints in national security and governmental financial resources, current drafting policy of the ROC Armed Forces shall adopt coexisted recruitment-conscription system, which is suitable for our national status quo. In the future, such policy may be gradually adjusted to address adoption of recruitment system with conscription system as supplement. Besides, paying taxes has been the consensus of the ROC Armed Forces. However, in light of the special nature of the military undertaking, the MND will submit a thorough taxation plan, which will not decrease salaries of the servicemen, to meet the governmental policy.
 8. Compared to the climbing military budget of the PRC, which even tripled during the last decade, the ROC's military budget has been on the decline and the military balance between the two sides is truly tilting. In line with the growth of overall national economic development, the MND expects its military budget can be sufficiently kept so as to maintain the combat readiness of the ROC Armed Forces and the national security.
 9. When disaster arises, the ROC Armed Forces always actively conducts relevant rescue missions and disaster relief operations in the first place. In order to eliminate further casualties and damages, the ROC Armed Forces will spare no efforts to assist the reconstruction works so as to realize the spirit of organic community, create a close relationship with the general public, and at last achieve the goal of all-out defense.

Prologue

The Republic of China (ROC), founded on the "Three Principles of the People," shall be a democratic republic of the people, to be governed by the people and for the people. It will unswervingly strive to attain to freedom, democracy, and even distribution of wealth.

With this premise, as well as the current condition that the two sides of the Taiwan Strait, namely the ROC and the People's Republic of China (PRC), are under separate rules, the national interests of the ROC at this stage are

- * ensuring its survival and development;
- * maintaining the security and wellbeing of its people; and
- * ensuring a democratic institution and basic human rights.

To secure the said interests will require strong national power as a backbone, accompanied by political stability, prosperous economy, social

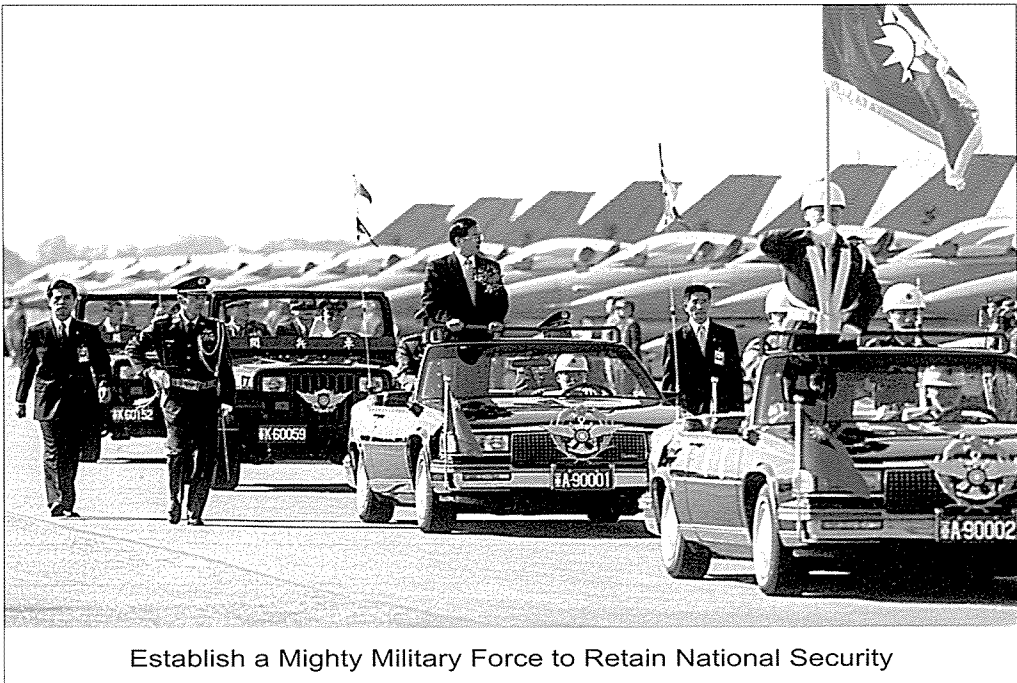

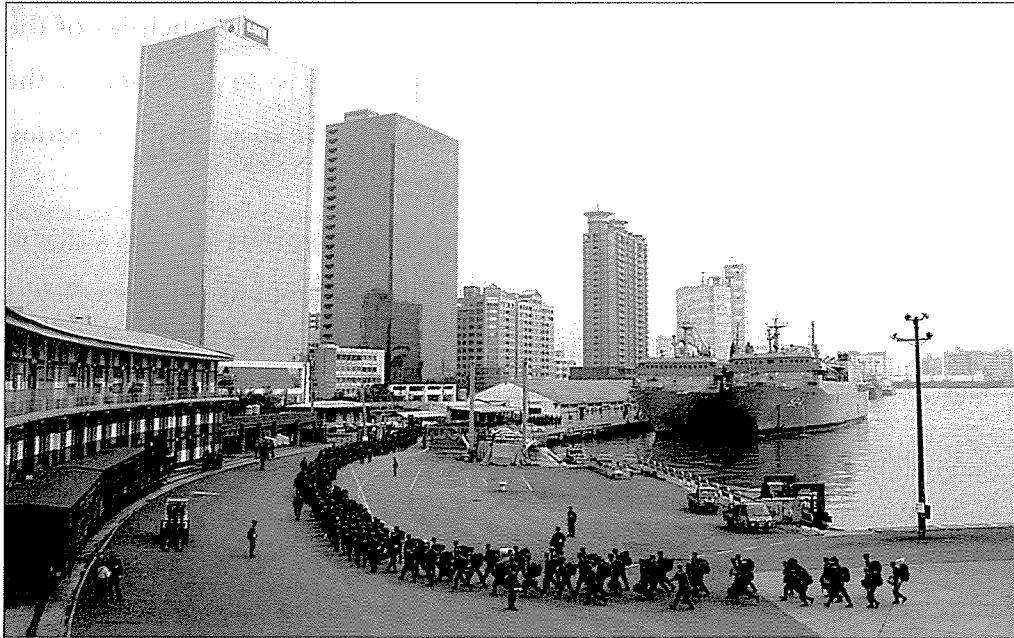

National Survival and Development Depend on a Strong National Power

stability, pragmatic diplomacy, innovative science and technology, as well as a powerful armed forces with credible deterrence. Only when the said interests are insured can the people in Taiwan enjoy a peaceful life and pursue their respective personal achievement; the society develop and progress; the country be managed in a sustainable fashion. Ultimately, the ROC wishes to be able to make contributions to peace of the human race.

PART ONE |
INTERNATIONAL SECURITY ENVIRONMENT
AND MILITARY SITUATION

Summary

1. At the onset of the 21st century, the international environment manifests itself in a pattern of multilateral cooperation. The desire to gain substantive economic benefits has taken the place of confrontations and conflicts. The concept of security indeed has expanded beyond a single military or political perspective to include economic, energy, environmental protection, and technological implications.
2. The terrorist attacks on the U.S. homeland September 11th, 2001 stunned the world and greatly influenced international security. Strategic planning of many countries has also been affected. Threats from terrorism have created a sense of worry in international community.
3. In the global stage, potential threats contain several natures, such as political, economic and military ones, and could well be thrown in as unpredictable factors in international security. Ostensibly, the international security environment maintains its way to develop peace and stability. However, owing to interwoven problems of any kind, the international situations still wobble, and the uncertainties will thus wrap the prospective of the global security.
4. In Asia, the U.S., Japan, Russia and the PRC, all have respective but conflicting interests in this region. Furthermore, reconciliation between the two Koreas remains variable, the impasse between India and Pakistan is hard to resolve as well as the situation of the Taiwan Strait seems ever-changing, casting tantalizing variables to the regional security in Asia. However, every nation in this region still pursues reasonable ways to maintain peace and stability.
5. The PRC's publicly acknowledged defense expenditure is RMB \$ 160 billion in 2002, which increases 17.6% from RMB \$141.1 billion in 2001 and remains a double-digit growth. In accordance with changes in military strategy, the PRC improved the overall capabilities of the PLA Navy, Air Force and Second Artillery Corps and established a rapid response force, which are expected to transform the PLA into an offensive force capable

- of offshore operations. In addition, the PLA's constant military exercises in peripheral waters have been aggravating concerns from countries in the region toward the PRC's ambition in expanding its military strength.
6. The urgency of resolving "Taiwan Issue" has prompted the PRC to redirect its military attention toward southeastern coastal areas---an act creating worries among the people on Taiwan and seriously affecting the ROC's psychological defense. Moreover, the PLA is exploring assets and techniques for conducting information and asymmetric warfare, which are expected to diversify and sharpen the PRC's invasive activities into the ROC. The PRC's threat against the ROC's security is ever increasing.

International Security Environment

I. Security Challenges

At the onset of the 21st century, the international environment manifests itself in a pattern of multilateral cooperation. The desire to gain substantive economic benefits has taken the place of confrontations and conflicts. The overall international environment, though still fraught with uncertainties, has unrolled positive developments to the comfort of people around the globe.

However, people should remain mindful that the security environment could still be challenged by those dangerous, complicated and ever-changing factors throughout the world. Although global population comprises different races and ethnic groups, fast maturing information and internet technologies have connected the world into a global village. Disturbances in any region could very likely spread in no time to all parts of the world, exerting unpredictable impact.

In the post-cold war era, the global environment has transformed from a bi-polar confrontation into a situation of one superpower with multi-powers. The nature of their relations can interchange from competition to cooperation without clear clarification. The concept of security indeed has expanded beyond a single military or political perspective to include economic, energy, environmental protection, and technological implications.

Regional conflicts stemmed from fights over race, religious beliefs, territory, and resources remain challenges to global security. The terrorist attacks on the U.S. homeland on September 11, 2001 (911 incident) stunned the world and greatly influenced international security. Strategic planning of many countries has also been affected. Threats from terrorism have created a sense of worry in international community.

Other factors such as the proliferation of dangerous military technologies,

transnational crimes, drug trafficking, flows of refugees, are also challenging international security and threatening the lives and wellbeing of mankind.

II. Peacekeeping Efforts

The intertwining struggles over regional interests still bring about constant disputes and conflicts in parts of the world. Therefore, as we are entering the 21st century, the use of military power continues to be the sole means of peacekeeping. The respectable United Nations is still the most important moderator in international disputes. The independence movement in the East Timor of Southeast Asia, for example, was intervened by the UN when the world body sent in peacekeeping troops and helped convene a transitional Cabinet. With the policy of transferring the administrative and legislative powers to the people of East Timor within a definite timeframe, it hopes to facilitate a smooth process of building East Timor as an independent country.

After the 911 incident, the U.S.- and Britain-led allied forces toppled Taliban regime of the Afghanistan. The UN also played a leading role in establishing an interim administration in the country. The international community no doubt recognizes UN authority and its effectiveness to integrate, coordinate, and perform peacekeeping missions. It will surely continue to be the highest institution in the settlement of international disputes.

While the role of the UN in peacekeeping continues to expand, regional organizations are another source of crucial efforts in international peacekeeping missions. In light of new security challenges in the new century, regional alliances, such as North Atlantic Treaty Organization, European Union, Association of South East Asian Nations, Organization of African Unity, have to bear heavier responsibilities to cope with the situation. Bilateral or multilateral dialogues—the four party talks in East Asia, ASEAN

plus 1, or plus 3, Conference on Interaction and Confidence-Building Measures in Asia to name a few—can also be means of peacekeeping. In addition, formal or informal summits among heads of state have occasionally made positive contribution to regional situation.

III. Potential Threats

Although the world is developing toward a constructive and positive direction, several potential threats could well be thrown in as unpredictable factors in international security.

1. Potential Threats of Political Nature

Disputes over territorial sovereignty and overlapping territorial waters have always been one major cause of potential threats of political nature. Examples include the conflicts regarding Kashmir between India and Pakistan, sovereignty disputes over Spratly Islands, etc.

Racial and religious conflicts as well as separatism are also major sources of disturbances. The barriers and conflicts result from different races and religions, leading to emerging separatism and, in turn, regional war. Confrontation between Kosovo and Yugoslavia on the Balkan Peninsula; clashes between Israelis and Palestinians; skirmishes between Muslims and Christians; independence movement in Aceh Province of Indonesia; issues of the Kurds in Turkey and Iraq; and the independence-prone Albanians in Macedonia—incidents such as these remain factors influencing regional security.

The 911 incident has proven that paranoiac behaviors of religious fanatics could amount to great danger and impact on global security environment. Past terrorist activities were mostly supported and schemed by a few isolated countries. Now some countries in certain regions have joined in by covertly giving support to terrorism, constituting threats to security in such regions.

Countries all over the world agree that a stable international environ-

ment not only benefit their economic development and people's livelihood but is the only environment in which poverty can be eradicated and mutual prosperity achieved. However, as long as religious bickering and racial confrontation, along with separatism, are still prevailing, regional turmoil will persist in the short term.

2.Potential Threats of Economic Nature

Economic globalization is in the trend. Economic competitions are gradually replacing military confrontation. However, opposing elements involved in the process should not go unnoticed. First of all, continuing disparity in wealth between the rich and the poor is the one. Among World Trade Organization members, richer countries enjoy an average capital income of over US\$ 20,000, while poorer countries garner less than US\$ 1000. This serves to be a clear example. In this modern age when trade liberalization is highly stressed, the wider the gap is, the deeper the distrust among countries would be. This could be a potential threat for political, economic, and social development.

Secondly, many countries are trying very hard to gain accession into the WTO. Their hope is to be included in the global economic system, broaden their market access, and pursue economic prosperity. If not, monopolization of trusts could lead to economies scrambling for resources and plunge the world economy into another predicament. Moreover, the impact of globalization has triggered anti-globalization movement. Voices calling for inward-looking orientation are burgeoning. If the two opposing forces of pro- and anti-globalization clashed with each other, there could be consequences that serve neither side's interests.

Although the shadow cast by the 1997 financial crisis initiated from Thailand is gradually receding, the uncertain prospect of the global economy could still repeat the same plight, which could be another serious blow to countries with political instability and rising debt. In addition, bubble

economies, resulted from overestimating economic growth and tax revenue and overoptimistic investment and financial policies, seem to be re-emerging in certain countries. If such trend is not prevented in time, the results could range from sending a country into economic failure to threatening world economy by causing a chain reaction.

3.Potential Threats of Military Nature

Potential threats of military nature include arms race and problems pertaining to the proliferation and control of weapons of mass destruction (WMD), namely nuclear, biological and chemical (NBC) weapons. The lethality of NBC weapons has long caused international attention on their proliferation. Even though the Cold War has ended, a few countries are still aggressively trying to purchase, research, and develop NBC weapons, or searching for related technologies and raw materials. The international community still cannot get rid of the shadow of being caught in the horror of war.

Although the U.S., Russia, France, Britain, and The PRC made a joint declaration in 1998 to reiterate the intention of gradually cutting down nuclear arsenal and living up to the obligations and responsibilities under treaties banning nuclear weapons. The United States and Russia further signed the Moscow Treaty (a new nuclear arms reduction treaty) in May 2002, which are expected to slash each side's 6,000 active strategic nuclear warhead stocks to a total number between 1,700 and 2,200 over the next decade. However, there was no definite timeframe for phasing out the warhead stocks in this Treaty, of which the effect still remains to be seen. Countries such as North Korea, Iran, Iraq, India, and Pakistan have even stepped up research and development on such weapons and adversely affected international security and regional environment.

Nuclear weapons proliferation, aside from its military significance, also bears political implication. Nuclear-armed countries often try to flex

muscles with such technologies in an attempt to raise their international status. Under the circumstances, defusing threats of this nature would take countries adopting measures to reduce hostility or signing compulsory international conventions. The purpose is to limit or deny access to acquire nuclear weapons, gradually reduce existing nuclear arsenals and ultimately ease nuclear threats against global security.

4. Other Forms of Potential Threats

Global warming is crucial in that it dictates changes in global environment and possible natural disasters. The 1997 Kyoto Protocol put limitations on the emission of carbon dioxide. Although an agreement had been reached in November 2001, it remains to be seen whether signatories will truly abide by the limitations, especially among industrialized countries. In addition, transnational crimes such as drug trafficking, human trafficking, pirates, arms smuggling, and illicit trade of war materials have also created disturbances in countries and areas. These problems could even bring dangers to regional security as a whole, and destabilize the international community.

Global Military Situation

I. General Military Situation

In the beginning of the 21st century, regional conflicts, weapons proliferation, and speedy technological advancement have forced changes in war patterns. The pattern of international situation evolves in an intangible way, but can still be analyzed in the following aspects:

1. Regional Conflicts

In the past decade, military conflicts have continued after the demise of the Cold War. Chechnya in Central Asia, India and Pakistan in South Asia, Iraq of the Persian Gulf, Israel and Palestine in the Middle East, Yugoslavia, Kosovo, and Macedonia on the Balkans, have all seen military conflicts that directly and indirectly affect regional situation. Disputes of the two Koreas, the two sides of the Taiwan Strait, and South China Sea are also crucial factors affecting the security of the Asia-Pacific region.

The 911 incident in the U.S. prompted a global anti-terrorism campaign, which indirectly altered strategic balance in Central Asia, or even the whole Asia, as well as the global power structure. In the future, religious confrontations and terrorism-triggered conflicts will be the focal point of international attention.

2. Weapons Proliferation and Transfer

Countries around the world have been engaged in arms expansion to ensure its interests and security. The accelerating weapons proliferation in recent years enabled many countries to possess hi-tech, low-cost weapons of great danger, which could have serious implications for regional security. Examples include the PRC's export of high-grade steel, navigational guidance system, and missile technologies to Pakistan. The communist regime even provided technologies of NBC weapons and missile to

North Korea, Iran, Iraq, etc. These acts have all threatened to alter regional military balance. The 911 incident surfaced the fact that countries supporting terrorism all wish to be or have already been in possession of WMD. Therefore, the global campaign against terrorism will inevitably involve efforts in the obstruction of WMD proliferation and transfer.

3. Military Technology Advancement

Rapid advancement in science and technology has served as the engine of military technology development. Technologies in different fields such as computers, telecommunications, nuclear energy, biotechnology, chemistry, aviation, have reinforced one another in their utilization. Small, sophisticated, and highly lethal NBC weapons have been employed in military use. These developments have transformed the pattern of conventional wars into a widely different one. Moreover, the continuation of the concept of "Star War" and the development of "Theater Missile Defense System" could stretch battlefields into space and also result in a changing war pattern.

4. Changes in the Essence of War

The integrated employment of NBC weapons, precision-guided weapons systems, internet technologies, and virtual realities have initiated substantive changes in the concept, pattern and means of war, such as the asymmetric warfare and all-out defense. Also, the theory of "unlimited warfare" served as another impact as it brought forth combat skills of "fight against the big with the small, beat the many with the few, and counter regular warfare with guerrilla warfare." Furthermore, the use of the cyberspace has broadened the scope of Information Warfare. The EP-3 incident of April 2001 that triggered a cyber competition between the U.S. and the PRC testified to the significance of Information Warfare as well as information security. Technological advancement is bound to change fu-

ture war patterns around the globe, shorten the distances across the international community, and blur the lines between the front line and the rear areas. The evolvement of future war patterns hence will be even more intangible.

II. Regional Military Situation

Although hit by the 911 terrorist attacks, the U.S. still remains in the status as a global superpower and a world leader. The U.S.-led allied forces have attacked and toppled the Taliban regime in Afghanistan. With assistance from the UN and international community, Afghanistan has begun the process of reconstructing its political structure.

The PRC in recent years has been experiencing rapid economic and military progress, setting the foundation to be a regional power. However, its non-democratic mindset could still be a threat to the region. Russia's political and military strength has been affected by its longstanding economic sluggishness. The retaining strategic and tactical nuclear weapons, however, still gave the country certain influence in the region.

Japan Diet passed "the New Guidelines for U.S.-Japan Defense Cooperation" and related statutes to enhance the U.S.-Japan military cooperation in case of incidents in "situations in areas surrounding Japan"—an act inducing strong reactions from the PRC. In October 2001, Japan took advantage of situation at the time and passed "the Anti-Terrorism Special Measures Law," further broadening legal basis for Japan's participation in overseas military missions. This is expected to create certain impact on future patterns of defense cooperation as well as the security environment in the Asia-Pacific region.

The relations between the two Koreas and Japan seemed to be easing. Yet, Korean Peninsula's unification process was not able to produce any major breakthrough because North Korea's inconsistency in its intentions. The world is also keeping an eye on India's efforts in developing informa-

tion technology and nuclear prowess. India is poised to be even more influential in Asia with its potential in those two areas.

Bloody clashes between Israel and Palestine, resumed since September 2000, could not be quelled despite multiple efforts of international mediation and became the obstacle to peace in the region. The EU is gearing up to form a rapid reaction force, which is expected to start performing regional humanitarian relief missions in 2003. The EU is expected to have capabilities in maintaining regional security and in partaking of peacekeeping missions. NATO, in order to ease Russia's suspicion of its eastward expansion, is trying to promote exchanges, increase bilateral cooperation, deepen military ties, and build a foundation of mutual trust with Russia. The rapprochement process between the two sides is a positive development of the security environment in Europe.

Generally speaking, the international security environment is developing toward peace and stability. Yet, the complexity of related issues would still cause disturbances and remain a source of uncertainty and instability in the global security environment.

Military Situation in Asia

I. U.S. Security Strategy Toward Asia

The goal of the U.S. global strategy is to ensure its national security and economic interests, while promoting democracy and peace around the world. In “the Report of the Quadrennial Defense Review,” released in September 2001, the U.S. Department of Defense drew a new blueprint for national defense strategy, stressing homeland security as the top priority and emphasizing capabilities in response to surprise attacks and terrorist activities. As to Asia, the U.S. consistently emphasizes its stance of maintaining regional stability and balance in the region.

U.S. military deployment in the Asia-Pacific region focuses on building a multilateral security network, reinforcing forward deployment and power projection capability, enhancing military alliances with Japan, South Korea and Australia, and maintaining regional security and U.S. interests in the Asia-Pacific region. In addition, the U.S. is building intelligence exchange and military consultation mechanisms through bilateral or multilateral military exercises, purposing to strengthen regional alliances.

Due to a possible scenario that a military adversary with abundant resources could emerge in Asia, the U.S. is reinforcing its contingency response ability in the West Pacific and Northeast Asia. The U.S. is also considering the idea of adding a few emergency bases in the Pacific and Indian Ocean to work with regional allies in maintaining regional peace. Besides, the U.S. is also promoting military cooperation with Southeast Asian countries to broaden multilateral defense and security cooperation mechanisms.

In terms of Central and South Asia, the U.S., through multilateral efforts and various cooperative programs, attempts to maintain regional peace, curbs proliferation of NBC weapon technologies, and keeps terrorist activities in check.

II. Military Development in Asian Countries

1. Northeast Asia

(1) Japan

Japan passed “the Fourth Defense Build-up Plan” in December 2000, stressing “sufficiency in responding to various situations, improving defense capabilities, creating a more stable security environment, and building an appropriate self-defense force” that is efficient, small, powerful and sophisticated. Besides decisions to purchase advanced equipment such as shipboard helicopter destroyers, Kongo-class destroyers and air-refueling planes, the plan also specified duties of the self-defense force and emphasized making international contributions such as disaster relief operations.

After the 911 incident, Japanese Diet passed “the Anti-Terrorism Special Measures Law,” allowing the Self Defense Forces to deploy overseas to support U.S. logistic missions. The measures have provided a legal basis for Japan’s overseas operations, representing profound and long-term influence over military situation in the Asia-Pacific region.

Japanese Self Defense Forces is numbered at 236,000, consisting of 149,000 of the Ground Self-Defense Force, 43,000 of the Maritime Self-Defense Force, and 44,000 of the Air Self-Defense Force. The main weapons systems include 1,070 main battle tanks (MBTs), 16 submarines, 55 main surface combatants and 331 combat planes.

(2) South Korea

South Korea has been engaging in a vigorous process of military modernization, planning to acquire new-generation fighters, warships, air defense missiles, early warning aircraft, and tone up C³I capabilities. Under the premise of avoiding arms race and maintaining peace in East Asia, South Korea is improving overall defense capabilities and establishing a 21st century armed forces to work with U.S. in maintaining regional stability.

The Korean Peninsula has long been a hot spot that threatened stability in Asia. South Korean government in recent years has been promoting "Sunshine Policy." The government and private sector of the two Koreas have both tried to promote exchanges and cooperative programs, hoping to see gradual alleviation of military standoff and possibility of an accidental conflict, while accelerating the process of unification. However, while the U.S. Bush administration is reviewing its Asia-Pacific policy, the PRC and Russia take advantage of the situation to intervene in the affairs of the Korean Peninsula. Moreover, the opposing views expressed between the ruling and oppositions in South Korea and North Korea's reconsideration of its stance have stalled interactions and created uncertainties for the vision of unification.

South Korea's total force is about 690,000, comprising 560,000 of the Army, 67,000 of the Navy, and 63,000 of the Air Force. The main weapons and equipment are 2,250 MBTs, over a dozen submarines, some 170 combat ships, and 520 combat planes.

(3) North Korea

Using its nuclear weapons and ballistic missiles as bargaining chips, and at the same time seeking international aid to ease its economic plight, North Korea has won diplomatic recognition from the U.S. and Japan and successfully sending itself onto the international stage.

Most of North Korea's defense budget was used for arms expansion. Its transfer of missile equipment and technologies into South Asia and the Middle East also added to regional instability. In recent years, the U.S. and Japan are trying eagerly to conduct dialogues with North Korea, urging it to stop exporting missile technologies and conform to international norms. The effect, however, still remains to be seen.

North Korea has a total force of 1,170,000, comprising the Army's 1,000,000, the Navy's 60,000 and the Air Force's 110,000. The main weapons and equipment are 3,800 MBTs, 50 submarines, 430 combat ships,

and 850 combat planes.

(4)Russia

After the demise of former Soviet Union, Russia took over the position as an international legal person, but was unable to maintain past international status due to economic recession and declining national power. After President Putin's assumption of office, there have been positive signs indicating that political and economic crises are turning for the better. With NATO's active eastward expansion, Russia is anxious to make use of mechanisms such as "Shanghai Cooperation Organization" and "The PRC-Russia Good-neighborly Treaty of Friendship and Cooperation" to prove that its strategic significance did not decline with the collapse of former Soviet Union. After the 911 incident, Russia rendered strong support for military campaign against terrorism. In such a friendly atmosphere, the U.S. and Russia had signed "the Moscow Treaty" in May 2002, reaching an accord that the each side will reduce nuclear warhead stocks to a total number between 1,700 and 2,200. The development of future U.S.-Russia relations is worthy of attention.

In order to improve its economic condition, Russia has been selling weapons and equipment to the PRC and the third world countries. Besides improving domestic economy, developing defense industry, and replenishing arms stocks, those arms deals also served strategic purposes of maintaining Russia's influence and involvement in regional affairs. Russia's current force is about 1,200,000, comprising 150,000 of Strategic Deterrent Force, 440,000 of the Army, 200,000 of the Navy, 210,000 of the Air Force, and 200,000 of command and logistic personnel. The main weapons and equipment are 21,970 tanks, 67 submarines, one aircraft carrier, 34 main surface combatants, and 2,733 combat planes.

2.Southeast Asia

Southeast Asia holds the major juncture between the Pacific and Indian

Ocean. Countries in the region have been focusing their attention on economic development. Though once hit hard by a financial crisis, most of the countries have gradually recovered economically, and are planning to phase in military modernization programs. For force structure of Southeast Asian countries, please refer to Table 1-1.

The Philippines and Indonesia experienced political power transfer in January and July 2001, respectively. The ensuing political instability damaged domestic order and investment climate. However, situations in the two countries have been gradually improving.

There have been incidents of ethnic and religious conflicts in Indonesia for the past few years. The independence movement in East Timor even prompted the UN to send peacekeeping troops into the area and helped establish a transitional government for political power transfer and, ultimately, completing the independence process.

The U.S.-led military operations after the 911 incident provoked Muslims in the region to voice support for Afghanistan. Anti-U.S. sentiments were heightened as a result, especially in Indonesia and Malaysia. Fortunately, the situation did not deteriorate further.

Southeast Asian countries have been conducting joint military exercises with the U.S. and other countries to enhance their overall defense capabilities. They have also been strengthening bilateral and multilateral dialogues in the region. The PRC was also included in those dialogues for the benefit of increasing mutual trust, mitigating hostilities, and avoiding possible conflicts.

3.South China Sea Disputes

South China Sea is blessed with abundant oil and natural gas reserve. It is an important fishing area and holds sea lines of communication connecting the Middle East and East Asia. The unique geographical position gives the area strategic significance, involving interests of many countries.

Table 1-1
Current Military Strengths of Southeast Asian Nations

Unit: TS for "Troop Strength" in Approximate Number of Effectiveness in Parentheses

Service Nation	Total troop Strength	Army	Navy	Air Force
Indonesia	297,000	(TS 230,000) 275 Light Tanks	(TS 40,000) 2 Subs 17 Frigates 36 Patrols	(TS 27,000) 108 Fighters 42 Helicopters
Philippines	106,000	(TS 66,000) 40 Light Tanks	(TS 24,000) 60 Patrols 9 Amph Vessels	(TS 16,000) 47 Fighters 97 Armed Helicopters (AHs)
Singapore	60,500	(TS 50,000) 63 MBTs 350 Light Tanks	(TS 4,500) 1 Sub 6 Amph Vessels 24 Patrols	(TS 6,000) 136 Fighters 20 AHs
Malaysia	96,000	(TS 80,000) 26 Light tanks 10 Helicopters	(TS 8,000) 4 Main Combatant Vessels 2 Amph Vessels 41 Partols	(TS 8,000) 84 Fighters 46 Helicopters
Thailand	301,000	(TS 190,000) 50 MBTs 145 Light Tanks	(TS 68,000) 1 Helicopter Carrier 14 Frigates 9 Amph Vessels 88 Patrols	(TS 43,000) 153 Fighters 42 Helicopters
Brunei	5,000	(TS 3,900) 16 Light Tanks	(TS 700) 6 Patrols	(TS 400) 5 AHs
Laos	29,100	(TS 25,000) 30 MBTs 25 Light Tanks	(TS 600) 16 Patrols	(TS 3,500) 14 Fighters 27 Helicopters
Vietnam	484,000	(TS 412,000) 45 MBTs 300 Light Tanks	(TS 42,000) 2 Subs 6 Frigates 42 Patrols	(TS 30,000) 189 Fighters 26 AHs
Cambodia	95,000	(TS 90,000) 100 MBTs	(TS 3,000) 4 Patrols	(TS 2,000) 24 Fighters
Myanmar	344,000	(TS 325,000) 100 MBTs 105 Light tanks	(TS 10,000) 68 Patrols	(TS 9,000) 83 Fighters 66 Helicopters

Unit: Person

Source: "The Military Balance: 2000-2001", Int'l Inst. of Strategic Studies, London

When compounded with intertwining historical sentiments, the area often became a focal point of regional conflicts.

There are a total of 192 island reefs in South China Sea. Countries involved

in sovereignty disputes over 48 island reefs are the ROC (occupies Itu Aba Island), the PRC (occupies 8 islands), Vietnam (occupies 27 islands), the Philippines (occupies 9 islands), Malaysia (occupies 3 islands), and Brunei (claims sovereignty over Louisa Reef). The current situation of the Spratly Islands is shown in Chart 1-1. Vietnam stations the largest number of troops in the area—over 2,000—followed by the PRC’s 600 troops, and then the Philippines’ 100 plus troops.

Those countries declared their sovereignty by concretely occupying islands, leading to incidents such as the armed conflicts between the PRC and Vietnam on Paracel Islands and Spratly Islands in 1974 and 1988 respectively. In order to alleviate disputes, ASEAN countries advocated a South China Sea Code of Conduct. However, incongruous stances of countries and conflicts of interests diminished chance of progress in the short run. On this issue, the PRC supports the idea of “setting aside sovereignty disputes and jointly exploiting resources in the area.” Its approach to the disputes is keeping a low profile and actively participating in ASEAN affairs. The U.S. and Japan, though not directly involved in the disputes, pay much attention on the situation. The U.S. has been reiterating a peaceful resolution and stressing free passage of sea lines of communication (SLOC) in South China Sea. The superpower also tries to strengthen relations with ASEAN countries, thus continues to be influential over the issue. Japan, with “the U.S.-Japan Security Treaty”, stressed free passage of SLOCs as well. It enthusiastically participates in ASEAN dialogue, attempting to reduce the PRC’s influence and protect its own interests. Other countries such as Russia, New Zealand, Australia, are also expressing concerns over the issue by involving in regional economic activities.

4.South Asia

(1) India

Although the U.S. has increased financial aids to Pakistan out of the need

Figure 1-1 The Current Situation of the Spratly Islands

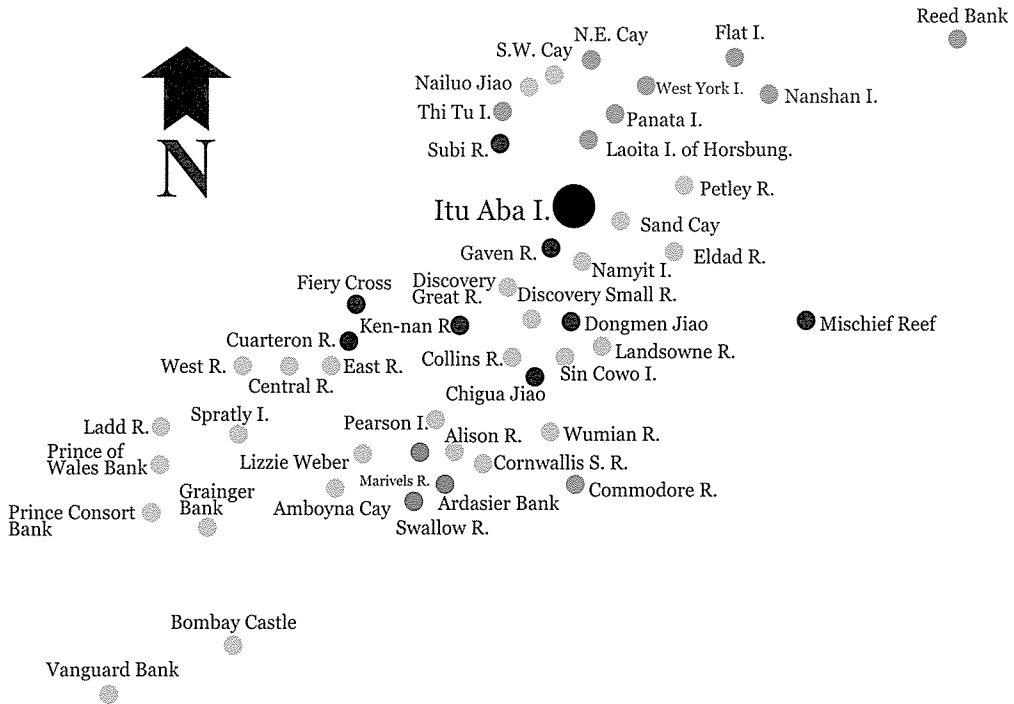

Nation Division	ROC	PRC	Vietnam	Philippines	Malaysia
Islands Being Occupied	1	8	27	9	3
Color	●	●	●	●	●
Current Forces Stationed	10	590	2,020	102	88
Reason for Occupation	Sovereignty Claim	Sovereignty Claim	Sovereignty Claim	Sovereignty Claim, Economy Development	Sovereignty Claim, Economy Development

Note: The personnel of the Coast Guard Administration of the Executive Yuan deployed on the occupied island are not included in the ROC Armed Forces.

for anti-terrorism campaign, the established Washington-New Delhi partnership will unlikely be affected. India has substantially increased defense budget for two consecutive years to cope with the bulky organization of its military—which ranked as the 4th largest in the world. It is planning to purchase advanced fighters, early-warning aircraft, air-refueling planes, high-altitude unmanned aerial vehicles, and Russia-made T-90 tanks, etc.

The policy orientation of “consolidating the subcontinents, marching toward Indian Ocean, developing a nuclear force” guides New Delhi in the struggle to achieve as a military power and a regional power. Through military exercises, India showcased its nuclear and traditional forces in front of the countries in South Asia, endeavoring to boost its international influence. India’s military exercise dubbed “Operation Complete Victory” of May 2001 served as a warning for the PRC and Pakistan, cautioning that any intruding military operations into its border will prompt rapid reactions from India. The exercise also told the world that India still retains traditional warfare capabilities despite of being nuclear capable.

India’s total force is 1,303,000, comprising 1100,000 of the Army, 53,000 of the Navy, and 150,000 of the Air Force. The main weapons and equipment are 3,414 MBTs, 16 submarines, one aircraft carrier, 25 main surface combatants, and 774 combat planes.

(2) Pakistan

Pakistan has long enjoyed cordial relations with the PRC, from whom it received assistance to develop nuclear weapons and missiles. The military strength of the country cannot be overlooked. After the 911 incident, Pakistani president expressed support for anti-terrorism activities, thus won the U.S. relaxing restrictions and granting financial aids. In the future, the evolvement of Pakistan-PRC-U.S. relations will continue to affect peace and stability in South Asia.

Pakistan has a total force of 612,000, comprising 550,000 of the Army, 22,000 of the Navy, and 40,000 of the Air Force. The main weapons and equipment are 2,285 MBTs, 10 submarines, 8 main surface combatants, and 353 combat planes.

5. Central Asia

Following the 911 incident, Afghanistan became the target of global campaign against terrorism, leading to complete collapse of the Taliban regime. Under UN leadership, different ethnic groups in Afghanistan agreed to establish “a transitional government”, so as to redesign a political prospect for the war-torn country. However, complicated factions in the country posed as uncertainties in the reconstruction process. The future of Afghanistan is still uncertain.

With the outbreak of the 911 incident, Kazakhstan, Uzbekistan, Kyrgyzstan, Turkmenistan, and Tajikistan were courted earnestly by powerful nations—the U.S., the PRC, and Russia. These Central Asian countries have thus become more strategically important in the international community. Traditionally, Russia plays the leading role in Central Asia’s military, economic, and diplomatic arenas. However, the anti-terror campaign brought Uzbekistan to sign a military cooperation agreement with the U.S., thus becoming a major U.S. military partner in Central Asia. Tajikistan also signed an agreement with the U.S., making its military bases available for the superpower. Kyrgyzstan allowed U.S. troops to use its airfield. Kazakhstan allowed its air space and land passable for the U.S. transports. Obviously, U.S. military involvement in Central Asia has achieved a historical breakthrough.

Central Asia has served as a back door for the PRC. The promotion of “Shanghai Five” dialogue mechanism and the establishment of “Shanghai Cooperation Organization” (Note 1) have shown how the PRC attached great importance to the region. The elevation of strategic status and the

abundance of natural resources are bound to bring Central Asia to the center stage of struggles among leading powers.

Note 1: In 1996, heads of state from the PRC, Russia, Kazakhstan, Kyrgyzstan, and Tajikistan gathered in Shanghai and established the organization of “Shanghai Five” with an aim to strengthen economic cooperation and jointly fight against terrorism. On June 14, 2001, a meeting was held in Shanghai, where Uzbekistan was formally admitted as a member. On July 5, heads of state of the six member countries issued a “Dushanbe Statement” in Tajik capital; renaming “Shanghai Five” into “Shanghai Cooperation Organization” to further strengthen cooperation.

III. Implication of Asia’s Military Situation for the ROC

The U.S., Japan, the PRC and Russia compete conflicting interests in Asia, reconciliation between the two Koreas remains variable, the impasse between India and Pakistan is hard to resolve as well as the situation of Taiwan Strait seems ever-changing, casting tantalizing variables to the regional security in Asia. Asian countries, though caught by global economic recession, still prioritize defense build-up. The 911 incident has made homeland security and prevention against terrorist attacks a new focal point of national defense. Regional balance could be altered accordingly.

The U.S. still maintains 100,000 troops in the Asia-Pacific region. Through combined military exercises with Japan and South Korea, the superpower remains influential in the region. Japan, besides establishing a small, sophisticated and efficient self-defense force, made use of the situation after the 911 incident and passed “the Anti-Terrorism Special Measures Law” for dispatching self-defense troops to perform overseas missions—a move bound to affect Japan’s interaction with countries in the region. South Korea is also boosting its defense force and at the same time trying to improve relations with North Korea and to accelerate unification process. The PRC continues to strengthen traditional force and strategic deterrent capabilities. The communist regime is developing strategic partnership with North Korea and Russia in an attempt to counter U.S. influence, augment its national

power and raise its international status. Russia has completed the plan for force reduction, but its national power can no longer compare with past glories due to persisting economic recession. Moscow might have to resort to its strategic nuclear weapons and arms export to regain military superiority and remain influential in the region.

Asian countries have all been devoting themselves to promote regional peace and stability. Southeast Asian countries, through ASEAN Foreign Ministers Meeting and ASEAN Regional Forum, periodically hold meetings among foreign ministers and conduct multilateral security dialogue. The PRC, Japan, South Korea have all been included in those dialogues for the purpose of strengthening mutual trust and consensus. The 911 incident prompted countries to join in an anti-terrorism alliance, which bears a positive meaning to regional peace and stability. The PRC's successful bid for hosting the 2008 Olympics was welcomed by all countries, which deem it a guarantee of near-term peace. However, a non-democratic communist China that suppresses separatism in the name of anti-terror cause could still threaten security in the Taiwan Strait. Asia's overall military situation does not pose as an immediate pressure for the ROC, but could still present uncertainties for military balance and regional security.

Military Situation in the PRC

I. Strategic Environment

Under the slogan of globalization, the PRC has been attracting capital from East Asian countries to fulfill its ambition of building an East Asian economic circle with itself at the core. Politically, the communist regime is shaping itself into a regional power by participating in various bilateral dialogues and establishing strategic partnership with other countries. The aim is to pierce the picture of the U.S. as the sole superpower and prevent it from dominating global affairs, while raising Beijing's international standing and directing the world order toward a multi-polar system. Especially since the implementation of "Reform and Open" policy, a solid foundation has been laid for pursuing the goals of modernization in agriculture, industry, and technology. "The fourth defense modernization plan" is also in the full swing. The PRC is preparing itself to be one of the leading powers of the multi-polar system in the future. The strategic environment that Beijing is faced with is analyzed as follows.

1. External Environment

(1) The United States

Beijing and Washington have long held major differences regarding issues on Taiwan, Tibet, commerce, religion, and human rights. Accidental bombing of the embassy compound in Belgrade in May 1999 and the collision between a U.S. surveillance aircraft and a Chinese fighter in April 2001 twice heightened tension between the two. Nevertheless, the stakes in overall strategy and economic development have been keeping the two sides on a right track leading to constructive relations. Beijing's U.S. policy in the future will continue to follow the guidelines set by Chinese President Jiang Zemin in 1990, which laid out principles of "in-

crease trust, reduce trouble, expand cooperation, and avoid confrontation.”

(2)Russia

While suffering domestic political and economic instabilities, Russia's overall national power declined substantially. To solidify Russia's standing in the Asia-Pacific region and to save its defense industry with capital from the PRC, President Putin, soon after his assumption of office, signed the PRC into Russia's strategic partner. Besides siding with Beijing on many international issues, Moscow has stepped up military cooperation. The PRC has also been taking the advantage to grab economic benefits and accelerate military modernization with the help of Russia's high-performance weapons and defense technologies. President Jiang visited Russia in July 2001 to sign “the PRC-Russia Good-neighborly Treaty of Friendship and Cooperation,” marking a step forward of relations. While there are no serious conflicts of interests and a stabilized situation at the borderland remains mutual desire, the two sides are expected to continue strengthening their cooperative relations.

(3)Japan

Relations between Japan and the PRC have long been volatile because of historical background and odds over “Taiwan issue.” More recent frictions of Japan's participation in the U.S.-led TMD system, Prime Minister Junichiro Koizumi's pro-U.S. stance and his insistence on visiting the Yasukuni war shrine and the falsification of the history textbook on Japan's invasion into the PRC have all had Beijing react with doubts and strong protest. Despite so, while Japan will rely on the PRC's assistance to resolve disputes regarding the Four Northern Islands and to gain a seat at the U.N. Security Council, the PRC also depends on Japan for economic and trade benefits to enhance overall national power. Under the circumstances, it is not likely to see too much tension in the relations.

(4)The European Union

Over a course of five decades, the EU finally completed economic

integration. In pursuit of “economic interests” and “integrated security”, the EU will further integrate political power of member countries, while reaching eastward to promote relations with the PRC. Also for the benefit of economic development, the PRC is likewise enthusiastic in entering European market and attracting capital from the region. The interactions between the two sides have thus been fairly frequent.

(5) Korean Peninsula

After the Korean summit, the tension on the Korean Peninsula has been moderating. This has a direct influence over the U.S. strategy toward Asia-Pacific area. The strategic environment in Northeast Asia has also been changed. A peaceful Korean Peninsula is in the interest of the PRC. And the unification of the two Koreas will challenge the legitimacy of U. S. military deployment on the peninsula. The PRC is thus giving every effort to urge Kim Jong-il’s reciprocal visit to Seoul to resume dialogue with South Korea. It can be anticipated that the PRC will use its influence to meddle in Korean affairs, seeking the maximum political interests.

(6) Southeast Asian Countries

“The ASEAN” and “ARF” are regional organizations established by Southeast Asian countries to strengthen cooperative relations based on concepts of integration and cooperative security. The PRC organized “Boao Forum” for Asia on Hainan Island in February 2001 to promote economic exchanges among Asian countries—an initiative that has won support from a few Southeast Asian countries. In November of the same year, the PRC Premier Zhu Rongji visited Brunei to attend meetings of “ASEAN plus three (leaders of ASEAN countries plus the PRC, Japan and South Korea)” and “ASEAN plus one (the ‘eleven plus one’ leaders meeting of the PRC and ASEAN countries).” A consensus was reached in the meetings to establish an ASEAN-PRC free trade zone in ten years. To maintain border security, crack down criminal activities, and increase influence over Southeast Asian countries, the PRC will certainly

strengthen political and economic cooperation with ASEAN countries to secure existing interests in the region.

(7)South Asian Countries

Since Pakistan separated from India and became an independent state in 1947, four large-scale military conflicts had occurred between the two countries mainly due to the disputes over Kashmir's sovereignty and religious differences. The PRC, since its relations with India deteriorated in the 1960s, has been providing aid for Pakistan as a means to curb India's hegemonic ambition—a policy that made India and Pakistan a major flashpoint in South Asia with their ethnic, religious and territorial disputes. The two countries each conducted nuclear tests respectively in May 1998, rendering a probability of nuclear war in the region. The U.S. enhanced relations with India in the wake of the events—an act watched carefully by the world. In December 2001, an explosion took place in India's parliament. Indian government pointed its finger directly at Pakistani terrorists. The two sides increased troops at the border, escalating tension in the area. However, the U.S.-Pakistani relations turning closer in the wake of the 911 incident brought impact on ties between Pakistan and the PRC. Whether disputes in this area can be resolved to the benefit of regional peace will have to rely on the chance of successful mediation by the major powers such as the PRC, U.S. and Russia. The security and stability of the PRC's southeastern border will also be affected accordingly.

(8)Central Asian Countries

The abundant oil reserve and constant religious and racial disputes have made Central Asia a region with the highest possibility of a full-scale conflict. Especially after the 911 incident, Afghanistan became the main battlefield of an anti-terror war, further complicating situation in the region. Despite doubts that the U.S. is expanding influence into Central Asia, the PRC still voiced support for the U.S. in fighting terrorism

with an eye on political and economic interests and the opportunity to curb independence movement in Xinjiang Province. To broaden its influence in Central Asia, the PRC, aside from making use of the existing mechanism of “Shanghai Cooperation Organization,” will try to secure ties with allies by increasing economic aid to the region.

(9)South-Pacific Island Countries

South-Pacific island countries are mostly small, loosely populated countries that had historically been colonized or under trusteeship of the U. S., Britain or Australia. Among them, Palau, Marshall Islands and Nauru have formal diplomatic ties with the ROC and are also important fisheries and stations of Taiwan’s deep-sea fishing industry. Countries around the world are feeling increasing need for ocean resources, especially the PRC, who uses them to develop a blue-ocean navy and squeezes the ROC internationally. Beijing is playing money diplomacy to lure countries in this area, such as Tonga, Fiji and Papua New Guinea, to exert its influence and chip away Taiwan’s established diplomatic ties with countries in this area.

(10)The Taiwan Strait

Since the Democratic Progressive Party (DPP) became ruling party in the ROC government, the PRC has been adopting a low-profile attitude of “listen to the words and watch the deeds” in terms of cross-strait relations. Beijing has used every bit of its power, trying to pressure Taiwan into accepting the “one-China” policy on its own term. In December 2000, the PRC released its Defense White Paper stating “Taiwan’s indefinite procrastination of negotiation” as one of the conditions to use force against Taiwan. The PRC President Jiang Zemin declared in the 5th Plenum of the 15th Party Congress that “unification of the motherland” is one of the three pillar missions for the PRC in the new century. After the return of Hong Kong and Macao, the urgency in resolving “Taiwan issue” has emerged. Militarily, the PRC is staging frequent exercises aim-

ing at “countering the U.S. and Japan, preventing Taiwan independence. ” Under the circumstance, a crisis of military confrontation could still be triggered in the Strait.

2. Internal Environment

The PRC is facing manifold internal problems. Politically, separatist movement of ethnic minorities in Xinjiang, Tibet, and Inner Mongolia gave rise to one another. “Issues of Falun Gong activities” and human rights have not been resolved, either, exhibiting obvious inability of the PRC over domestic issues. Economically, discrepancy between economic policies and industrial development, institutional imbalance, and corporate earnings being perennially in the red have caused problems such as disharmony in regional economy and widening poverty gap. Despite the western areas being developed with great exertion and WTO membership obtained, easing those economic problems remained a challenge not sure to be surmounted. Socially, the policy to reform state-owned enterprises has caused a hike in the number of unemployed workers to 12 million people. The “illiteracy flow” drifting between rural and urban areas also amounted to 80 million people. In addition, an unhealthy mentality of seeking financial gain is pervading throughout the society in both public and private sectors, resulting in worsening problems of graft and corruption. In order to stabilize domestic situation and resolve existing problems, Beijing authorities are bound to rely even more heavily on its armed forces. Once domestic problems become a threat to political regime, it is highly likely that the PRC will try to divert internal dissatisfaction by taking outbound military actions.

II. Military Strategy

The Persian Gulf war and Kosovo war have left the PLA deeply impressed with western countries’ professional elite forces and high-tech weaponry

capable of conducting “stand-off and beyond-visual-range (BVR) precision strikes.” The ensuing revolution in military affairs created an even stronger impact on the PLA leaders’ military thinking. High technology has been recognized as the key to victory in modern warfare.

The Central Military Commission (CMC) held an enlarged meeting in January 1993 to adjust the orientation of military strategy, bringing forth the principle that the core of military preparation lies in employing modern technologies to win a local war, especially a local war under hi-tech conditions. The main endeavors are as follows,

(1) Strategy Directions

The PRC is focusing most of its attentions on economic development, attempting to strengthen military might through growing financial power. In terms of military strategy, Beijing stresses the avoidance of initiating a war, especially a large-scale war. When a war is inevitable, it will be restrained from escalating into a nuclear war or medium-scale war. Therefore, Beijing is trying to establish capabilities for winning a localized hi-tech war under its control. The major directions of possible operations are: 1) southeast coastal areas of the Chinese mainland; 2) South China Sea; 3) Sino-Indian border areas.

(2) The Strategy for Territorial Waters

Military modernization has substantially enhanced the PLA’s force projection capability. Accompanied with upgraded national power and future strategic planning, the PRC has taken actual steps to manage territorial waters. Regarding the southeastern front, attempts were made to prevent U.S. and Japanese intervention into the Taiwan Strait. The PRC wishes to widen its strategic defense depth from “the first island chain” into “the second island chain” (islands from Bonin Islands along the center line of the Pacific, through the island of Iwo Jima, to Mariana Islands). For southern front, gradual steps were taken to strengthen its Navy and Air Force joint distant capabilities over South China Sea, while securing

the sovereignty of the island reefs in the attempt to include South China Sea as its territorial waters and control abundant resources in the region. The PRC's naval strategy of active defense has therefore been transformed from "coastal defense" to "off-shore defense" and is gradually marching toward the blue ocean.

(3) Focus of Military Development

The PLA is actively engaging in military modernization. Besides improving personnel quality, developing capabilities of its Navy and Air Force is prioritized. To enhance the Army's overall combat capabilities, strengthen the Second Artillery Force's capability and establish a rapid response force will also be stressed.

(4) Upgrading Strategic Deterrent Capability

In terms of conventional force, the PRC is focusing on improving precision and lethality of ballistic missiles, which are to enter into mass production, while developing cruise missiles and submarine-launched missiles, so as to boost up strategic deterrent capability. The launch of several reconnaissance, communications and navigation satellites aimed at enhancing the PLA's C³ISR capability in joint operations. The "aero-space strategy" is also being developed in theory.

In terms of unconventional force, the theories of "asymmetric warfare" and "unlimited warfare" put forth by some in the PLA both stressed blurring the lines between battlefield and non-battlefield when faced with an eminent adversary, using various military or non-military means to create advantages and snatch victory.

When facing modern warfare or envisioning future hi-tech warfare, the concept of the PRC's military strategy, though premised on hi-tech conditions, still insists on following the guidance of Mao Zedong's military philosophy and Deng Xiaoping's ideas of new-era military buildup. There remains the traditional strategic for thinking about ways for inferior to prevail over the superior and are still emphasizing the deterrent

power of the “People’s War.”

III. Current Force

Despite on-going force streamlining, the PRC’s armed forces are still comprised of the regular PLA force, People’s Armed Police, militia, and the PLA reserve force.

1.The PLA

(1)The total forceof the PLA is about 2,320,320, comprising of Army: 1,505,935, Navy: 347,305, Air Force: 339,350, Second Artillery: 128,000. Estimated ratios of breakdowns are shown in Figure 1-2.

(2)The PLA’s current force deployment is guided by the strategic guideline of “winning a campaign in remote area quickly, wining the first campaign decisively”, conceiving potential threats according to geo-strategic nature of the Chinese mainland. The “theater strategy” is mapped

Figure 1-2 Estimated Armed Forces Strength Ratio of the PRC

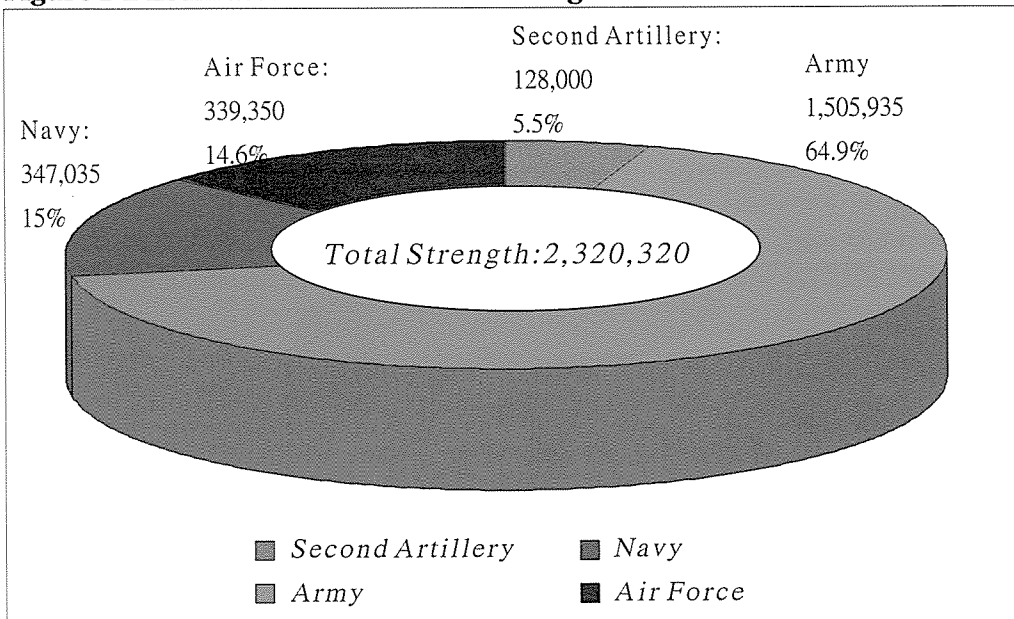

out based on demarcation of the seven military regions and deployment of the PLA Army, Navy, Air Forces and Second Artillery. For assessment on the PLA deployment, please refer to Figure 1-3.

(3)The PLA has an arsenal of over 500 DF-series short, medium, long-range, and intercontinental missiles. The DF-15 (M-9) missiles are deployed in Leping of Jiangxi Province. The forward deployment sites are scattered around areas in Jiangxi and Fujian Province. The modified DF-11 (M-11) missiles can cover the whole island of Taiwan if firing from their present launching sites in Fujian. Missiles deployed in these areas are clearly for potential Taiwan targets, and the number is increasing. It is estimated that, by 2005, the deployed missiles targeting at Taiwan will increase to around 600.

(4)After taking over Hong Kong and Macao, units were established under Guangzhou Military Region to be officially stationed in the two areas.

Figure 1-3 Estimated Ground Forces Deployment of PLA

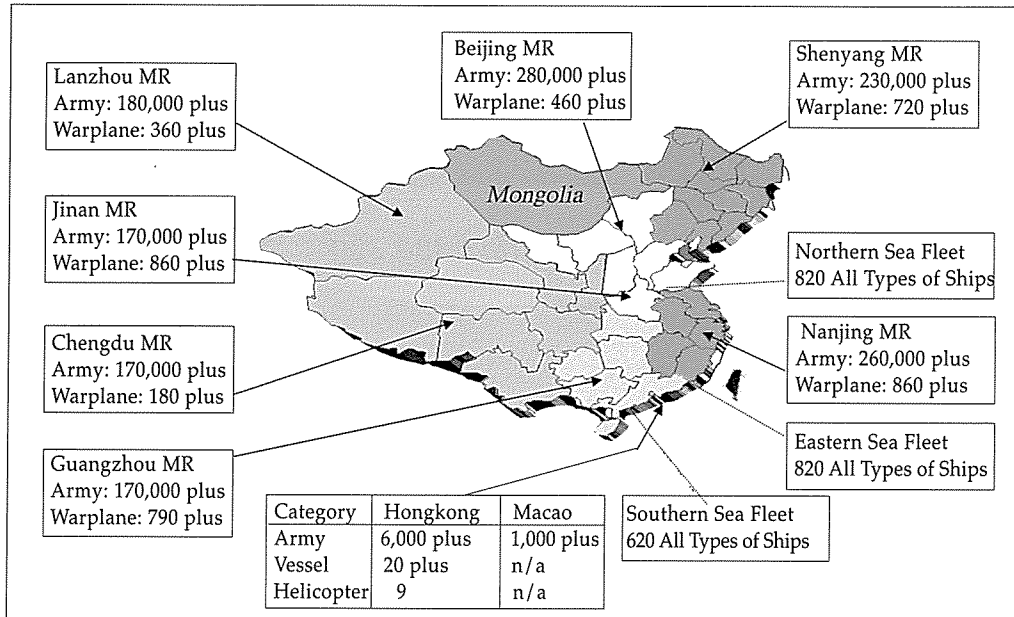

The 6,000 troops in Hong Kong have been equipped with 21 armored personnel carrier vehicles, 9 helicopters, and over 20 naval vessels. The 1,000 troops in Macao were equipped with 10 armored personnel carrier vehicles and over 60 vehicles of other kinds. The two specially-organized units comprising of army, navy and air force were aimed at demonstrating the PRC's resumption of jurisdiction over the area's land, waters and air space, while testifying the ability to implement "one country, two systems" policy and to maintain the PRC's territorial integrity. The two units will mainly be performing duties of anti-submarine missions, patrolling, anti-smuggling, anti-human smuggling, anti-insurgency missions and urban warfare.

2.The People's Armed Police

The People's Armed Police (PAP) has a total force of over 930,000 personnel. It performs missions of both public security and military nature. In response to domestic situation and the need to transform international profile, the PRC, concurrent with arms reduction effort, is transferring part of its armed forces to a expanded armed police force, attempting to alleviate pressure from the theory of "China as a threat" circulated through the international community. PAP units are grouped into five categories: internal garrison, forest protection, transportation, gold, and utilities. Their peacetime duties are to protect crucial establishments and key officials, maintain social order, respond to emergencies, and protect strategically important resources such as forests and mines. In wartime, they will fall under military command to be in charge of maintaining battlefield order, anti-infiltration, and sentry and patrol missions, which can be categorized as "support battle line, secure home front" missions, assisting regular troops in defense operations.

The use of military means in cracking down on "the Tiananmen movement" of 1989 invited severe international condemnation and boycott. The

role of the PAP has since become even more important. The Central Military Commission declared in 1994 "if domestic instability occurs, the PAP will be the main force to be deployed." Suppression most of the independence movements in Tibet and Xinjiang and Falun Gong activities was carried out by the PAP, indicating the PAP as the chief force in maintaining internal stability.

(1)Command Structure

The PAP is under the command of both the Central Military Commission and the State Council. In the "Regulations Governing the Work of the PLA's Armed Police Force Commands" promulgated in June 1997, the headquarters was elevated from the level of "Military Districts" to that of "Military Region." Since 1997, the PLA has been transferring 14 field divisions under the command of the PAP, renaming them as "armed police mobile divisions," to be in charge of responding to emergencies across the mainland.

(2)Future development

The role of the PAP is set in-between a democratic country's military police and police force. It is equipped mainly with light arms. Because of the unique nature of duties, the PAP has been given mobile vehicles such as wheeled armored vehicles, command vehicles, and detection vehicles. Aerial reconnaissance units equipped with airships and helicopters were also established. Compared to the public security police force, the PAP has better capabilities in long-range mobile deployment and emergency response. Some of the headquarter-level units have participated in exercises of the PLA, therefore capable of suppressing large-scale domestic insurgencies in peacetime and supporting combat operations in wartime.

3.Militia and Reserve Units

In 1997, the PRC promulgated "Defense Education Law" and set out prin-

ciples for human and material mobilization in the “Defense Law,” further institutionalizing militia and reserve units; establishing “People’s Armed Department” at local governments; strengthening basic militia facilities and emergency militia units; and intensifying training of militia and reserve units.

(1)Militia

The manufacturing sectors in districts, villages and towns were grouped as militia in a so-called “labor-military combination” manner, engaging in economic production in peacetime and, in wartime, bearing duties of rear-area defense operations, reinforcement mobilization, supporting frontline operations, and logistic support. The PRC has been reinforcing maritime militia units with a focus on strategically important areas of southeast coastline. In recent large-scale landing operation exercises, maritime militia has mobilized large number of civilian boats.

(2)Reserves

The PRC is now expanding this reservist force, establishing a division in a province, a regiment in a region, a battalion in a county, and a company in a township. The reserves, numbered over a million now, comprise mostly of discharged or retired PLA officers and soldiers, who have better military know-how than the militia and have been the main force in the PLA mobilization. It was found that some of the dissolved PLA units were reorganized as reserve divisions and regiments, absorbing excessive personnel under arms reduction policy. The reserves have also been professionalized as a multi-functional force with independent units of artillery, anti-artillery guns, tanks, communications, pontoons, transportation, vessels, etc. The Second Artillery units are “non-equipped formations” serving as the PRC’s main mobilized force.

IV. National Defense Mobilization

Guided by the mindset of “People’s War,” the PRC’s national defense mobilization follows principles of “unifying the military and civilians, linking peacetime and wartime, cultivating soldiers’ quality in the people.” The militia and reserve units are organized in peacetime to facilitate wartime mobilization. The mobilization follows a central leadership with the military regions responsible for organization and coordination and provincial/municipal authorities in charge of execution of missions. Mobilization institutions are established at governments of all levels by local sectors and military authorities of the same level. Currently, there is at least one division- or regiment-level reserve unit in each county. These units, in peacetime, are under the command of military regions. In wartime, they can join PLA operations after being properly organized and equipped. Also, each city and county has its people armed department with key missions of drafting and mobilizing, city defense, and air defense.

When faced with a war, mobilization will be conducted in six major areas of arming, economy, air defense, science and technology, politics, and combat-ready transportation. To enhance management and mobilization effectiveness, the PRC Central Government established “National Defense Mobilization Commission” in 1994 with officials from the Central Military Commission, General Staff Headquarters, and State Council. Strategic material depots and mobilization offices at local governments were also established. In 1997, provincial- and county-level National Defense Mobilization Commissions were also established to take charge of local mobilization affairs. A complete structure has since been in place.

V. Defense Budget

The PRC’s publicly acknowledged defense expenditure was RMB \$ 160 billion in 2002, which increased 17.6% from the previous year. The PRC

claimed that the budget increase was used on maintaining the operation of certain PLA components after the ban on engaging in commercial activities; looking after retired officers; giving a pay raise to military personnel; covering expenditure on the troops stationed in Macao; and acquiring hi-tech weapons and systems to cope with future warfare. For official figures of the PRC's defense budget over the years, please referred to Table 1-2 and Figure 1-4.

The PRC's defense budget is drafted by General Logistics Department. It comprises three major categories: personnel expenses, operation & maintenance and cost of weapons and equipment, each taking one third of the total budget. However, there is in fact a considerable sum of expenditure concealed in non-military budgets, such as the budgets for non-military organizations including the Commission of Science, Technology and Industry for National Defense, Aerospace Industry General Corporation, Light Industry General Association, Ministry of Power Industry, Ministry of Machine-Building (Electronics) Industry, Ministry of Metallurgical Industry,

Figure 1-4 Statistics of the PRC Defense Budget from 1992 to 2001

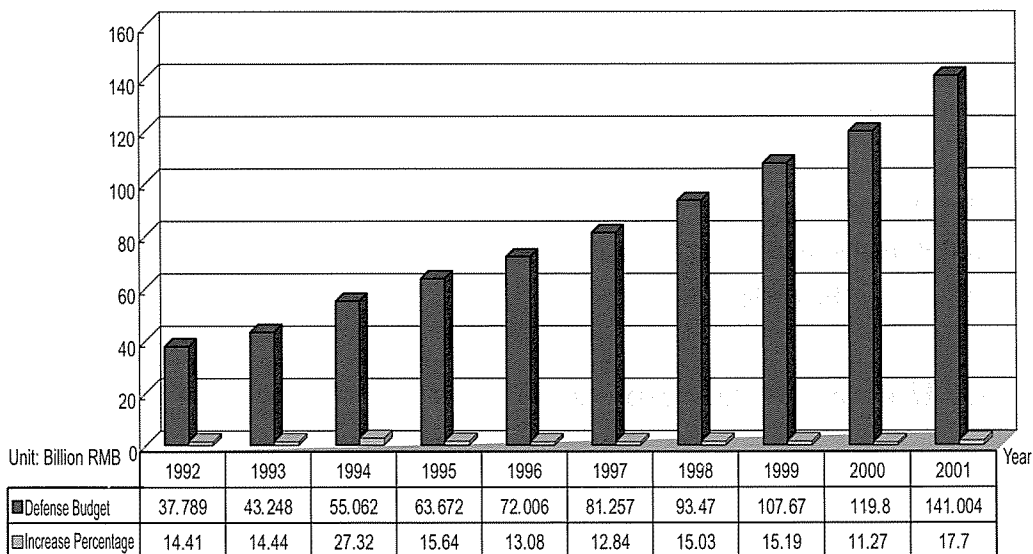

Table 1-2 Defense Expenditure of the PRC in the Last Decade

Unit: Billion RMB \$

Year	Defense Budget (DB) (Total Increase Rate)	Total Financial Expenditure(TFE) (Total Increase Rate)	Gross National Product (GNP) (Total Increase Rate)	US\$(Billion)	Exchange Rate
1992	37.789 (up 14.41%)	442.646 (8.54%)	2,393.6 (1.58%)	6.630	1:5.51
1993	43.248 (up 14.44%)	498.247 (8.68%)	3,516.1 (1.23)	7.457	1:5.76
1994	55.062 (up 27.32%)	581.976 (9.46%)	4,380.0 (1.26%)	6.330	1:8.70
1995	63.672 (up 15.64%)	681.219 (9.35%)	5,765.0 (1.10%)	7.581	1: 8.40
1996	72.006 (up 13.08%)	791.275 (9.10%)	6,793.0 (1.06%)	8.572	1: 8.29
1997	81.257 (up12.84%)	923.375 (8.80%)	7,454.8 (1.09%)	9.801	1: 8.29
1998	93.470 (15.03%)	1,077.1 (8.66%)	7,955.3 (1.17%)	11.201	1: 8.29
1999	107.670 (15.19%)	1,313.7 (8.20%)	8,205.4 (1.31%)	12.898	1: 8.29
2000	119.800 (11.27%)	1,587.46 (7.54%)	8,940.4 (1.34%)	14.451	1: 8.29
2001	141.004 (17.70%)	1,735.83 (8.12%)	9,566.2 (1.47%)	17.009	1: 8.29

Ministry of Civil Affairs (for retirement pension), Ministry of Finance. The non-military categories include basic infrastructure, city maintenance, culture and education, scientific research, and sanitation. According to estimates by U.S. Arms Control and Disarmament Agency, the PRC's 2002 actual defense spending can amount to RMB \$ 498 billion, three to four times higher than the official number.

VI. Military Development

In the post-Cold War era, global strategic environment went through drastic changes. Past military threats from continental borders that the PRC has faced with are now gradually being replaced by those from strategic alli-

ance and sea containment formed by the major powers including the U.S., Japan and India. Accordingly, the PRC's military deployment is now shifting its focus from the inland areas to coastal areas. Besides continuing development of strategic nuclear deterrent force, the PLA is streamlining ground troops, strengthening the capabilities of its Navy and Air Force, as well as the Second Artillery.

In terms of military deployment, the PLA is developing a new “**three offenses and three defenses**” tactics which means countering stealth aircraft, cruise missiles and armed helicopters and defending against adversary surveillance and reconnaissance, electronic jamming and precision strikes. The idea is to prevent advanced countries from using their superior air power and electronic/information warfare capabilities to compress the strategic depth of the mainland. The PRC's guidelines for “**off-shore defense strategy**” are as follows,

1. Yellow Sea and East Sea

Competitors in this area are the U.S., Japan, and South Korea. The priority is to deploy strategic deterrent force of nuclear submarines, Sukoi series fighters, FBC-1 fighter-bombers, DF series medium- and long-range ballistic missiles, etc.

2. South China Sea

The main issue in this area is the sovereignty disputes over certain islands. The priority is to develop rapid deployment, long range power projection for obtaining air superiority and sea control capabilities, such as Marine Corps, air-refueling planes, and upgraded F-8 fighters capable of air refueling.

3. First Island Chain

The key to implement the off-shore defense strategy for consolidating “the first island chain” is the resolution of the “Taiwan Issue.” Deployment along the southeastern coastline, which is increasing year by year, is therefore focused on the PLA's Navy, Air Force and Second Artillery

equipped with short-range ballistic missiles, advanced warships, submarines, landing ships and Sukoi series fighters capable of conducting depth strikes to pose threats to its adversary.

In the wake of the Persian Gulf War, the PRC has been facing challenges of the Revolution in Military Affairs. After extensive research and verification, the PRC concluded several new-century military development theories, such as "In modern warfare, all powers must be centered on employing its integrated air, ground, naval, space, electronic warfare forces to conduct multi-faceted strikes against the enemy." "Employing distant precision-strike firepower to launch stand-off, non-linear deep strikes against the enemy." and "Recognizing the significance of information warfare superiority, thus information protection and countermeasures must be developed." According to those theories, organization streamlining, training reforms, and high military technology development have been striding forward. Compared to the antiquated weapons systems decades ago, the PLA's current organization and equipment have been greatly improved. However, there is still a long way to go before catching up with advanced countries in terms of the development and management of information technologies. "Transitional problems" such as a technological bottleneck and shortage of hi-tech manpower have to be surmounted first before an enhancement in joint operation command and control and electronic countermeasures can be achieved.

In recent years, the PLA's effort in information warfare has been focused on electronic warfare, while at the same time developing software, hardware, tactics and combat skills in key areas of C² warfare, cyber warfare, and psychological warfare. An auto-command system across services and an information countermeasure system were also established to strengthen C⁴ISR capabilities. Measures to launch electromagnetic pulse (EMP) attacks, computer virus attacks, and hacker infiltration were also explored, so as to obtain secrets, deceive the enemy, and paralyze enemy C² system. The

development of techniques in information psychological warfare can be used in launching exaggerated propaganda, spreading misinformation, and creating false impression for the purpose of intimidation, thus misleading the enemy's decision-making and undermining enemy morale. Combined knowledge from areas of strategy, intelligence, electronics, C², cyberspace, psychology is used in the PLA's information warfare. If effective, enemy's leadership and command mechanism of political, economic, military authorities could be seriously disturbed or paralyzed, leading to enemy's collapse even before a war starts.

The PLA also emphasizes the R&D of hi-tech armament and weapons systems, while increasing acquisitions of related equipment and technologies from Russia, Europe, U.S. and Israel, etc. The ground troops have started to convert to newly developed armor, extended-range artillery, rockets, armed helicopters, air defense missiles and machine guns, tactical ballistic missiles, etc. The PLA Navy has been equipped with Russia-made Sovremenny-class destroyers and high-performance silent Kilo-class submarines. Domestic R&D on advanced submarines, large combat ships, and an aircraft carrier has also been initiated. The PLA Air Force has been introducing Russia-made Sukoi fighters, airborne early-warning (AEW) aircraft, heavy transport aircraft, and air-refueling planes. Other weapon systems are expected to complete R&D phase and enter into service, such as multi-functional fighters, electronic countermeasure aircraft, unmanned reconnaissance aerial vehicles, area air defense missiles, medium-range air to air missiles, anti-radiation missiles, air-launched cruise missiles, etc. The Second Artillery is phasing out old fixed-site missiles with vehicle-mounted mobile-launched missiles, so as to increase survivability and rapid response ability. In addition, the General Ordnance Department has put several reconnaissance, communications, meteorological, and positioning satellites in space. This dual-use satellite system has provided as an assurance of the C⁴ISR capability indispensable for the PLA joint operations in the Asia-

Pacific region.

The PLA's development still focuses on the "Taiwan Issue" and possible, which will possibly attract foreign intervention. Therefore, an emphasis has been laid on the tactics, combat skills, and weaponry required for conducting landing, sea-denial, air domination, electromagnetic superiority and airborne operations as well as performing urban and mountain combats. In an situation where the PRC's defense expenditure and combat capabilities continue to increase with the ever-growing economic power and overall national power, the implications will not only be the threats against Taiwan but also an emerging arms race among Asia-Pacific countries, which will adversely affect regional peace and stability.

VII. Military Exercises

To cope with global military development and in line with the strategic guideline of "winning local wars under the modern high technology conditions" and its tactical thinking about being "equally well on the offensive and defensive," the PRC is continuing to strengthen training methods and improve training efficiency. It also focuses training exercises on the new "three attacks, three defenses" tactics, mobile contingency operation, sea-crossing landing operation, logistic support assurance, and joint operation capabilities. The attempt is to enhance the efficiency of the joint command and improve its overall combat capabilities.

Since 2000, except Nanjing and Guangzhou Military Region where joint amphibious landing exercises were specifically targeted, all other exercises were routine annual training activities with emphases on mobilization, rapid response, cyber warfare, information warfare and airborne operations. The intensity and targeting of those exercises has demonstrated an ever-improving joint operation capability, which is another increasing threat that the ROC cannot ignore.

VIII. Military Diplomacy and Cooperation

The goals of the PRC's military diplomacy can be categorized as "stressing one-China," "refuting the theory of China as a threat," "demonstrating military information transparency," "acquiring hi-tech weapon to strengthen its military capabilities" and "blocking Taiwan's weapons acquisition channels." Aspects involved include exchange visits of academics, exchange of port calls, exchange of researches, military exchanges, weapons transactions, and technological cooperation. The scope covers the manifestation of security policies, the acquisition of materiel and weapons, the enhancement of bilateral relations, and intensification of interaction. This military diplomacy can serve as positive catalyst in improving The PRC's international relations and maintaining globally security.

The PRC's military diplomacy is premised on national security and national interests. Establishing friendly relations with neighboring countries is one of the top priorities. Exchange visits were also required to bring about functional benefits. Forming a strategic partnership with Russia, for example, was aimed at improving its border security. Developing bilateral ties with the U.S. is for the benefit of raising its international status. These efforts have been the priorities of The PRC's military diplomacy in recent years.

Beijing's high-ranking officials visited over 120 countries around the world, including Russia and Greece in the past two years. Their counterparts from over 150 countries, such as the U.S., UK, Japan, Germany, Russia, were also invited to visit the PRC. Leaders from the Central Military Commission, General Staff Headquarters, General Political Department, General Logistics Department, and military delegations led by general officers from all services have all participated in military exchanges. The highest profile contact would be the U.S.-PRC military exchanges. In addition, the PRC has also been active on the stage of warship diplomacy. These activities, besides training seamen's ocean sailing capabilities, bear multiple functions

of flaunting national power, familiarizing with foreign militaries, sending regards to overseas Chinese communities, and displaying weapons systems equipped on board to promote weapons export.

The PRC's military diplomacy is oriented toward being "omnidirectional, multi-level, and broad-sphere." Besides consistently trying to establish "good-neighboring" relations with peripheral countries, the PRC is endeavoring to set up channels for exchanges and cooperation with major countries in the international community. Beijing has been developing military relations with a total of 13 countries. Especially alerting is the purchase from Russia of Su-27s and Su-30s and Sovremenny-class destroyers equipped with Sunburn missiles. Moreover, The PRC is exporting weapons to countries such as Egypt and Pakistan, attempting to consolidate bilateral relations and expand global influence. With broadening scope of foreign contacts, the PLA is having more says regarding the communist regime's foreign affairs.

IX. Implication of the PRC's military situation for the Asia-Pacific region and the ROC

1. Implications for the Asia-Pacific Region

In accordance with changes in military strategy, the PRC's defense budget has been increasing year by year to accelerate the process of military modernization. The improved PLA Navy, Air Force, Second Artillery and the establishment of a rapid response force are expected to transform the PLA into an offensive force capable of offshore operations. In addition, the PLA's constant military exercises in peripheral waters have been aggravating concerns from countries in the region toward the PRC's ambition in expanding its armament. The PRC's increasing military might and deeper involvement in Asia-Pacific affairs have had serious impact on the strategy and military affairs of countries in the region.

The U.S. is seeing the PRC as its principal regional competitor. Though

yet to be able to match up to the U.S., the PRC can still, in its peripheral area, obstruct U.S. political and military initiatives. Japan has shifted its defense focus from the north to the west front to cope with military threat from the PRC. Southeast Asian countries are, on the one hand, seeking to mitigate the PRC's threat by strengthening multi-lateral dialogues through security mechanisms such as the ARF. On the other hand, they have all been trying to boost up defense capabilities, thus maintaining the momentum of an arms race.

2.Implications for the ROC

The PRC has been devoted to modernization of its military. As Beijing increases military expenditures, acquires advanced weapons and equipment, sharpens defense R&D, and improves personnel training, its military threat against the ROC, boosted by existing quantitative edge and continuing qualitative enhancement, should be monitored even more closely.

The PRC deems high technologies the key to winning a modern war. Its strategic concepts revolve around winning a local war under hi-tech conditions, while stressing a new military strategy of "rapid and effective response to conflicts." Namely, the PLA must seize the initiative and launch overwhelming attacks against the enemy and be capable of ending a war at the earliest possible stage. The strategic guideline of "winning a campaign in remote area quickly, winning the first campaign decisively" has taken shape. It can be anticipated that, in the coming decade till 2010, the PLA will continue to strengthen its capabilities of its Navy, Air Force and improve its joint operation capability. By transforming "continental defense" into "peripheral defense," the PLA wishes to prevent foreign intervention into the Taiwan Strait.

The urgency of resolving "Taiwan Issue" has prompted the PRC to redirect its military attention toward southeastern coastal areas—an act creating

worries among the people on Taiwan and seriously affecting the ROC's psychological defense. Moreover, the PLA is exploring assets and techniques for conducting information and asymmetric warfare, which are expected to diversify and sharpen the PRC's invasion into the ROC. The PRC's threat against the ROC's security is ever increasing.

PART TWO
NATIONAL SECURITY
AND DEFENSE POLICY

Summary

1. In recent years, the Comprehensive National Power (CNP) of the PRC has increased continuously with its fast-growing economy. In addition, it has spared no efforts in expanding military force, thus posing greater threats to our national security in political, military, economic and diplomatic dimensions. Thus, our survival and development are confronted with these gruesome threats.
2. The current national security strategies aim to ensure national security and sustainable development through the utilization of political, economic, diplomatic, military, psychological, and technological means to fully exert the national power and maintain national interests based on values of freedom, democracy, human rights and equal distribution of wealth.
3. The national defense of the ROC aims to strengthen national power, establish defense force, defend national security and maintain national interests; the principles of the current national policies include "prevention of war," "maintaining stability in the Taiwan Strait," and "defending the national soil."
4. Major guidelines of current national policies include: strengthening all-out defense, institutionizing national defense organizations, developing modernized national defense, establishing crisis management mechanism, promoting regional security cooperation, and implementing the "three assurances" policy.
5. Based on its strategic concept of "effective deterrence, resolute defense," the defensive operations of the ROC Armed Forces are aimed at preempting "command of the air and the sea, conducting ground defensive operations, " and best performing joint combat capabilities. On the premise of obtaining information & electronic superiorities, keeping hostile unlimited warfare at bay, combining operations to command the air and the sea, ensuring ground operations, and defeating intruding enemy, the MND is working hard to establish a compact but delicate, quick responsive,

and highly efficient precision strike capability, so as to pose a strong posture of effective deterrence.

6. Currently, the modernization of the ROC Armed Forces and restructuring of each service are the focal points of the restructuring efforts undertaken by the MND. Each service will concentrate on developing of capabilities with its own characteristic so as to improve the ROC Armed Forces' comprehensive capabilities to conduct joint operations.

Overview of Security Situation

I. Security Environment

1. External Environment

The ROC's national security is affected by changes in the international situation; however, its major threat comes from the Beijing regime, which has never renounced the use of force against the ROC as a means to resolving cross-strait issues. According to its "one China" principle, the PRC has kept trying to obstruct our foreign initiatives in the international community by claiming time and again that the PRC represents the sole "China." As a result, our national security and interests have come under tremendous threats.

Located halfway in the West Pacific's "First Island Chain," Taiwan serves as a gateway to Pacific Ocean to the PRC, and is in a controlling position over the Taiwan Strait, the Bashi Channel, and the adjoining Pacific waters, connecting the southernmost end of Northeast Asia and the northern end of Southeast Asia and the South China Sea. Therefore, Taiwan is of immense geostrategic significance to the PRC's eastward expansion.

After the collapse of the former Soviet Union, the PRC switched its strategic focus from its northern frontiers to the southeastern waters in an attempt to pierce into the containment posture led by the United States, working vigorously to expand its force to the southern and northern waters of West Pacific. The act has constituted substantial threats to the sea lifeline and national security of the ROC and other countries in the Asian-Pacific region. Moreover, the increasing economic power of the PRC for the last decade has laid a solid foundation for the PLA; therefore, our national security is faced with severer challenges in this regard.

2. Domestic Environment

Aside from military threat from the PRC, menaces to our national security include domestic destabilizing factors. Some of our people, for example, are confusing foes with friends, or divided on the issue of national identity, undermining the unity of people against external threats. Furthermore, our economy is overly dependent on external trade and most of the resources needed are imported from abroad. This suggests that we are susceptible to shortage of essential strategic supplies as a result of disturbances from sea and air blockades by the enemy, which might heavily constrain the daily necessity of the general public and the normal functioning of society, jeopardize our internal stability, and ultimately convulse our national defense and security.

II. Analysis on the Situation of National Security

In recent years, the Comprehensive National Power (CNP) of the PRC has increased continuously with its fast-growing economy. In addition, it has spared no efforts in expanding military force, posing greater threats to our national security in political, military, economic and diplomatic dimensions. Thus, our survival and development are confronted with gruesome threats.

1. Political Threats

The Constitution of the PRC pronounces clearly in its preface that Taiwan is a part of the sacred land of China and the unification of China shall be the sacred responsibility of all Chinese people, including the people in Taiwan. In a speech to the 5th Plenum of the 9th National People's Congress (NPC), the PRC's Premier Zhu Rongji delivered the so-called "on China, three phases" (Note 2) theory for the first time; however, such rhetoric showed no softening of Beijing's policy towards Taipei. The PRC's goal of "unification of the motherland," along with "national survival" and "national development," has always been specified as the "national interests" of the PRC.

Note 2: The PRC has altered its perception of “one China” from the saying of “There is only one China, Taiwan is a part of China, and the sovereignty and territory of China cannot be severed.” to “There is only one China, mainland China and Taiwan belong to China, and the sovereignty and territory of China cannot be severed.”

At present, the major disagreement between two sides of the Strait is the conception on so-called “one China.” Ranking officials in Beijing regime have never made any concessions in this respect on account of nationalism and the mentality of “great unification.” Considering factors involving “mutual equality status,” “international development space” and “national security,” our government is not likely to fully accept the concept of “one China” defined by Beijing in the short term so as to avoid losing bargaining chips for future talks. Improvement of cross-strait relations can hardly take place in the near future unless two sides bring forth new concepts together and break away from the inherent bondage of the original conceptual framework.

On 21 February 2002, during a summit with the US President George W. Bush, the PRC President Jiang Zemin still stressed that the policy of “peaceful unification and one China, two systems” acts as the guideline to resolve the Taiwan issue. It’s obvious that the PRC has never been rid of using “double-faceted peace-war” strategy in this regard. Even though countries and organizations like the U.S., European Parliament, etc., have expressed concerns regarding peaceful resolution over the Taiwan issue, the PRC will still continue to force us to make more room for negotiations through the manipulation of nationalism, the appeal that “unification of the motherland” as a historical responsibility, and the increase of threats via military force.

With the approaching of the 16th Party Congress, leaders in Beijing are taking rather conservative approaches in mapping out the PRC’s policies toward Taiwan. As the PRC continues to enhance military preparedness, it is bound to impose much more verbal attacks and saber rattling to Taiwan.

The PRC's white paper on the "One China Principle and Taiwan Issue" has specified that "if Taiwan authorities refuse indefinitely to resolve the issue on cross-strait unification peacefully by virtue of negotiations, the PRC's government shall be forced to resort to all possible drastic measures, including the use of force, to maintain the sovereignty and territorial integrity of China so as to achieve unification." Obviously, Beijing is losing patience on "peaceful unification."

2. Military Threats

As the PRC continues to expand its military power, it has been working to update advanced weapons for its traditional combat power, and develop the so-called "asymmetric warfare capability," including space, electronic, information and acupuncture (precision attack) warfare, namely the capabilities of conducting the initial battle and the first strike in wars against the ROC. Furthermore, as a practitioner of "unlimited warfare," the PRC has never renounced the use of force against our country, and its capability to wage such a war is definitely worthy of our attention.

(1) Asymmetric Warfare Capability

In terms of space war, the PRC has successfully developed a strategic micro satellite known as "killer satellite," which is expected to be fielded by 2005. It can be used in high-tech space war and is capable of completely interrupting GPS signals as well as destroying airborne targets. Concerning information and electronic warfare, the PRC is working on the development of new electronic equipment to form a partial dominance in wars and seize electromagnetic superiority in wartime. Regarding information warfare, by 2010, the PRC's military will have possessed the key technologies capable of paralyzing C³I systems and spreading highly dangerous Internet viruses. At the same time, it will possess electromagnetic pulse weaponry and logic bombs, and establish information warfare simulation center and information warfare troops to demoralize

the ROC armed forces and destroy our chain of command.

As for acupuncture (precision attack) warfare, the U.S. military estimates that by circa 2010, approximately 50% of the PRC's cruise missiles might have achieved a CEP of 5 to 10 meters, and ballistic missiles 30 to 45 meters, constituting significant threats to our governmental administrations and military command establishments.

Furthermore, the PLA military academics have developed a so-called "unlimited warfare" theory to address a pattern of offensive, which surpasses any conventional boundary and concept of war. This theory encompasses using all necessary means, including interoperable weaponry and techniques in information warfare, financial warfare, terrorism, bio-chemical warfare, and all kinds of battle. Despite of not being a standard doctrine of the PLA, "unlimited warfare" theory has indeed posed a potential threat to our national security, and our defensive posture could be deeply compromised by the PLA's random use of military and non-military means.

(2) Conventional Operational Capability

The PRC still attaches great importance to developing its conventional operational capability. For instance, the PLAAF continues to purchase Russian-built advanced AEW aircraft, Su-27 and Su-30 series fighters, and domestic-built high performance fighters; the PLAN has acquired Russian-built Sovremenny destroyers and Kilo-class submarines and possesses domestic-built destroyers and submarines. It is estimated that the PRC's traditional air and naval combat power might qualitatively surpass that of ours by 2010.

3. Economic threats

The fast growth of cross-strait trade over the past few years has led to the ROC's gradual dependence on the PRC for trade. According to statistics of 2001, investment from the ROC private sectors in the Chinese main-

land reaches US\$ 2,670,000,000. It's obvious that our overdependence on the PRC for trade and the growing investments of the ROC's private sector in the PRC will slow down the improvement of the ROC's industries, which will hollow out eventually. In terms of external trade, our exports will face competition from the PRC's products. In the event that the PRC uses "trade" as a tool, it might successfully exert influence on the ROC by posing economic threats through means of "compelling officials with the people's power, manipulating political affairs with trade, and forcing unification with direct links," and such threats may well take a toll on our national security.

In international trade, we have long been isolated from economic cooperation in the Asia Pacific region. Under the vehement opposition of the PRC, we are nearly excluded from governmental organization conferences in East Asia (except for the APEC) and constantly edged out of economic activities in this region. The initiative of creating the PRC-ASEAN free trade zone proposed by Beijing particularly will put us in danger of being "marginalized." Under such situation, we will lose tremendous economic interests and advantage in the developing East Asia economic zone in the future.

4. Psychological Intimidation

"Verbal attacks and saber rattling" has always been the PRC's strategy to create social unrest and a sense of insecurity within our nation. As the PRC continues to upgrade its CNP and engulfs the results of its economic success into military infrastructure, the military status between the two sides of the Taiwan Strait may well off-balance. Furthermore, the PRC will increase the uses of psychological intimidation, like spreading negative media reports regarding our military exercises, and dispersing rumors and unfounded information, to yield a beneficial condition for its future attacks on our nation. Besides, it will also create fishery disputes, or dis-

patch armed fishing boats to disrupt our normal shipping activities; use fighters and naval vessels crossing the median of the Taiwan Strait, or test fire ballistic missiles toward the neighboring area of Taiwan to challenge our perseverance; activate rear infiltration or sabotage activities to disturb our stock market and damage our military and economic infrastructure, and create unrest in our society. Such vicious intentions will very likely impair the security and morale of our people.

5. Diplomatic blockade

The PRC has never changed its policy to blockade and isolate us in the international community. Living by the belief of “one China,” it persists in shoving and shutting us out of both governmental and non-governmental organizations (NGOs) as well as international forums by posing political threats to our friendly countries, luring them with promise of economic gain, and imposing diplomatic pressures on them. It also tries to interfere with arms sales of other countries to the ROC and make use of propaganda and media to produce misleading information. Its incessant attempts to blockade and isolate us internationally by means of diplomacy have sabotaged the fundamental security of our nation.

2002
NATIONAL DEFENSE REPORT

National Security Strategy

I. Significance of National Security Strategy

“National security” herein refers to sustaining national survival and development, ensuring national sovereignty and interests, elevating the nation’s international status, and safeguarding the well-being of the citizens; and “strategy” refers to buildup of strength, and the art of creating and utilizing advantageous options for the purpose of attaining the maximum success and favorable results in achieving desired goals. In short, “national security strategy” refers to the all-inclusive approaches or major plans for fulfilling national goals by way of political, economic, military, psychological, technological and diplomatic means. The framework and system of national security strategies is shown in Figure 2-1.

II. Factors Involved in the Making of National Security Strategy

1. National interests

“National interests” are the foremost needs of a nation and the foundation of national goal and grand strategy. The ROC’s national security strategies are specifically made to safeguard the following national interests:

- (1) Ensuring National survival and development.
- (2) Maintaining people’s safety and well-being.
- (3) Protecting democratic system and fundamental human rights.

2. National goals

“National Goals” refer to the specific goals a nation aspiring to achieve. They include permanent goals and goals in stages. With an aim to promote, support or defend national interests, they are usually categorized as economic, security and political goals. Article 1 of Constitution of the ROC

Figure 2-1 The System of National Security Strategies

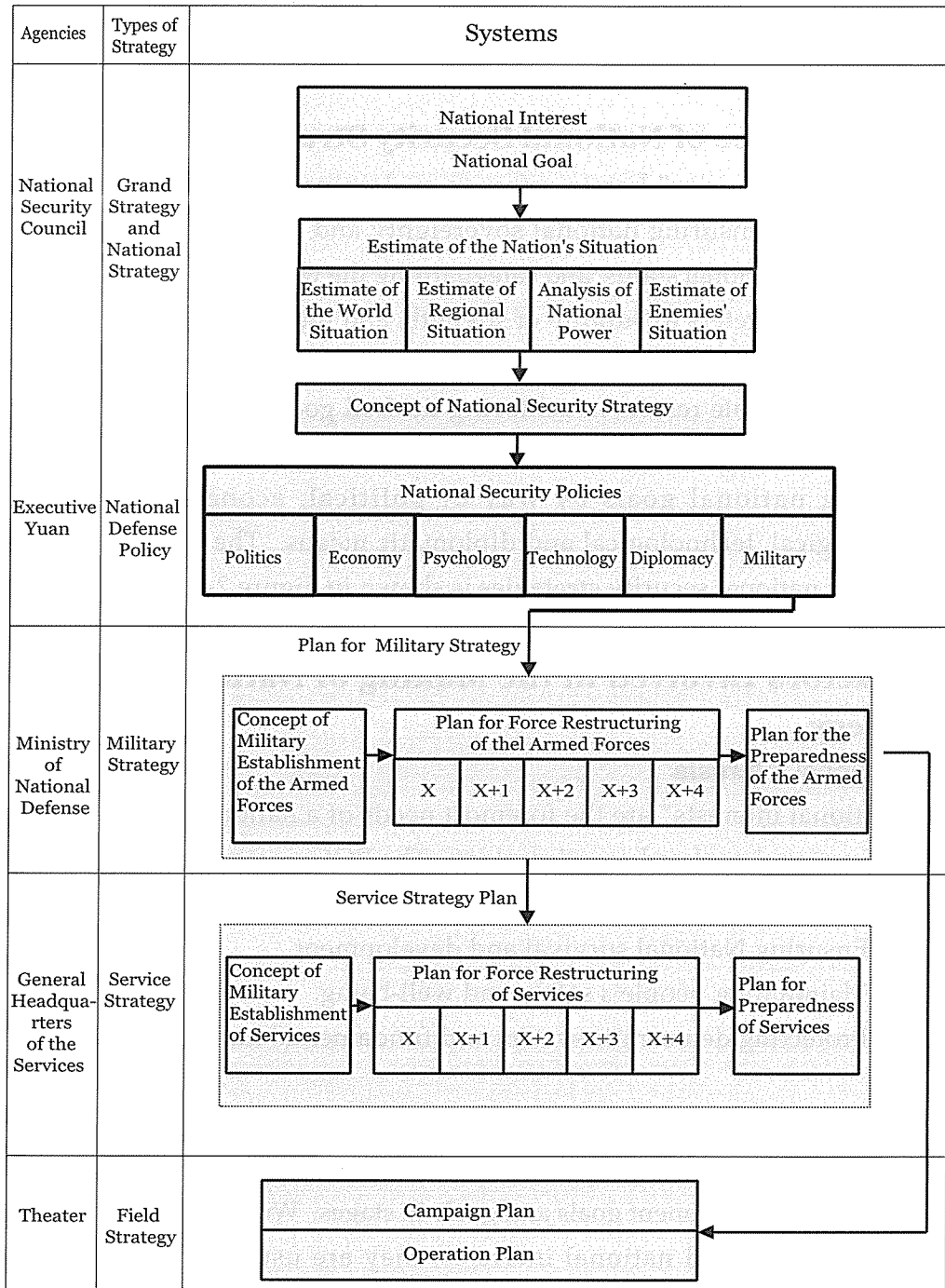

Note: Force Restructuring Plan spans 5 years. X indicates the plan for base year.

states that “The Republic of China, founded on the Three Principles of the People, shall be a democratic republic of the people, to be governed by the people, and for the people.” It clearly identifies that establishing a modern country of the people, to be governed by the people, and for the people, is the perpetual national goal of the ROC. However, in light of the fact that the country is now governed by two political entities, and for the interest of the nation at present, (specific) national goals in stages have to be identified. The current goals of the ROC are as follows:

- (1) Ensuring the independence and integrity of national sovereignty.
- (2) Maintaining stable relations across the Taiwan Strait and promoting peace and stability of the Asian-Pacific region.
- (3) Maintaining prosperity and economic growth and ensuring national survival and development.
- (4) Taking root on Taiwan and eyeing the global market.

III. Conceptual Framework of National Security Strategy

The current national security strategy aims to ensure national security and sustainable development through the utilization of political, economic, diplomatic, military, psychological, and technological means to perform national power to the fullest, and maintain national interests following the ways of pursuing freedom, democracy, human rights and equal distribution of wealth.

In political dimension: upholding democratic constitutional system, maintaining legal system aloof, promoting restructuring of governmental organizations, advocating neutralization of civil servants, protecting fundamental human rights, and improving welfare of the people.

In cross-strait dimension: opening up channels for peaceful cross-strait talks, expanding cross-strait exchanges, and promoting co-existence and mutual prosperity.

In economic dimension: promoting upgrade of industries, focusing on en-

vironmental issues, boosting economy, and enhancing comprehensive national power.

In diplomatic dimension: promoting three major policies of promoting “democratic human rights,” “economic coprosperity” and “peace & security,” and realizing the all-people diplomacy concept.

In military dimension: establishing all-out defense capabilities, strengthening all-out psychological defense, continuing national defense reforms, realizing nationalization of the ROC Armed Forces, and establishing a compact but delicate, and highly capable force.

In technological dimension: enhancing technological development, promoting research of state-of-the-art science, and creating technological advantages.

National Security Policy

National security policies are national defense policies in a broad sense, consisting of political, economic, military, psychological, technological, and diplomatic policies. Such policies are proposed by relevant government agencies, integrated by the Executive Yuan and promulgated by the President. Comparatively, national defense policies are national security policies in a narrow sense, namely military policies, which constitute the major part of national security policies. They are formulated and implemented by the MND.

According to Article 3 of Chapter 1 of the National Defense Law, the national defense of the Republic of China involves military defense, all-out defense and other political, economic, psychological, and technological affairs that may directly or indirectly contribute to the protection of the nation; Article 10 of Chapter 2 specifies that the Executive Yuan shall formulate national defense policies and integrate national resources; and in accordance with Article 11, the Ministry of National Defense, which is in charge of affairs of national defense, shall put forward suggestions pertaining to national policies and formulate military strategies. In compliance with the above-mentioned articles, the MND hereby brings forth the following suggestions pertaining to our national security:

1. Establish sound cross-strait policies and promote benign interaction between two sides of the Taiwan Strait

We have to put aside disputes, expand the scale of cooperation, promote exchange, strengthen mutual trust and assure stability between two sides of the Taiwan Strait. Based on the principle of “good-will reconciliation, proactive cooperation, and perpetual peace,” we have to create benign interactions across the strait to continue pushing for the normalization of cross-strait relations. Besides, we have to promote communications and exchanges on the existing foundation, and even out differences between the two sides with concerted efforts to cement mutual trust and seek perpetual peace.

2. Actively practice all-people diplomacy and expand international space

Gaining international status is vital to our national security. In order to strengthen ties with friendly nations and improve substantive relations with countries without diplomatic ties, we have to follow diplomatic strategies like “all people diplomacy (with participation of all people)” and “plural diplomacy” to promote “democracy-based diplomacy” and “human rights-based diplomacy.” In addition, we have to actively participate in international organizations via the liberalization and globalization of trade, and expand our contributions to the international community in an effort to do our part for the whole world.

3. Develop sound economic base and take deep root in Taiwan’s global prospective

We have to assist industries in overcoming present hurdles, develop knowledge-based economy through innovative approaches so as to improve the overall economic base within the nation. Besides we also have to enlarge infrastructures, promote deregulations, consolidate financial industries, and improve investment environments. In addition, we have to establish national land protection systems, enhance environmental education, and balance environment and development. Based on the concept of “consider Taiwan firstly, and broaden global prospective,” we will adopt active open policies and effective management to carry on the promotions of interactions in trade across the strait.

4. Promote the people’s participation in national defense affairs and reach the consense on all-out defense

In order to recognize that “national defense and national security are duties of everyone, and everyone is responsible for establishing national defense infrastructure,” we have to bring up a consense of survival, which is “concerned, supported, and participated by all the people. Furthermore,

under the impulse of psychological build-up, we have to improve our awareness, maintain the spirit of organic community and cohesion, so as to form an unbreakable force to defend our nation.

5. Promote R&D to attract investment and create superiority via advanced technologies

In order to promote R&D to attract investment and create superiority via advanced technologies, we have to

- (1) Map out “Plans for National Science Development”, develop national science and technology, and promote comprehensive development of technologies.
- (2) Foster academic cooperation in technology between governmental agencies to promote forward-looking research of defense technologies.
- (3) Push for research of state-of-the-art science, introduce high-tech industries and promote research, development, and innovation.
- (4) Devote to the development of space technology, promote research of major state-of-the-art technologies for private sectors and national defense, and create edge in major technologies to boost the comprehensive national power.

6. Establish a force with autonomous defense technologies and maintain security via all-out defense concept

In order to establish a force with autonomous defense technologies and maintain security via all-out defense concept, we have to:

- (1) Utilize limited national defense resources, formulate goals for the development of national defense technology as a whole, enhance independence in the research and development of national defense technology, and build up high-tech a defense force featuring a posture of effective deterrence and resolute defense.
- (2) Establish a well-defined mobilization mechanism, solidify civil defense system, strengthen the general public’s psychological defense, es-

establish all-out defense mechanism, and best perform intangible combat capabilities; obtain defensive strength from the people, combine operations in peacetime and wartime, consolidate defense capability, and at last prevent war from happening.

7. Realize democracy to protect human rights and develop a clean and effective government with sound systems

We have to abide by the constitutional system; establish consensus of national policy; assure democratic development, enhance social welfare; carry out human rights education and safeguard fundamental human rights; ban corruption and prevent irregularities, establish a government that is incorruptible, efficient, visionary, vibrant, highly flexible and responsive, take initiatives for national development, and consolidate comprehensive national power. Besides, with our experience in pursuing ideals of democracy, freedom, and human rights, we also have to enhance exchanges with peace- and democracy-loving countries so as to promote a democratic model for our neighboring countries.

Under the current circumstance where the PRC does not rule out the possibility of using force against Taiwan, formulating national security strategies as consensus and guidance for future national development to cope with a wide range of present and potential threats is a prerequisite for ensuring our national survival and sustainable development.

The current national defense policies of our country have taken into account prospective threats from enemies and changes in strategic environments, evaluation of available national resources, as well as the advice from all. These policies comply with national interests and goals, and adhere to the concept of "all-out defense." The ROC Armed Forces will abide by these policies to propose military policies, outline strategies, and build an elite military force to perform combat capabilities, as well as achieve the goals of safeguarding the lives and properties of the people and maintaining everlasting peace and stability of our nation.

National Defense Policy and Military Strategy

I.Objectives of National Defense

Article 137 of the Constitution of the Republic of China stipulates that “The national defense of the Republic of China aim to safeguard national security and maintain world peace.” Furthermore, Article 1 of Chapter 1 of the National Defense Law stipulates that “The national defense of the Republic of China shall, through the utilization of national resources and the establishment of defense forces, achieve its objective of defending the nation’s security and maintaining world peace.” These two articles have manifested the objectives of our national defense.

II.Fundamental Concepts of National Defense

In response to internaional strategic enviroment and the military threats from the PRC, the current national defense policy of our nation is based on concepts of “prevention of war,” “maintaining stability in the Taiwan Strait,” and “defending the national soil.” These concepts are explained as follows:

1. Prevention of war: preparedness of the national defense aims to build a sustainable defense capability to avoid conflicts and wars.
2. Maintaining stability in the Taiwan Strait: through dialogue and exchange of security issues between two sides of the Taiwan Strait, we hope to promote transparency in military affairs on both sides to increase mutual understanding so as to maintain stability and security in this region.
3. Defending the national soil: we have to uphold “truce but no fear of war, be militarily prepared but not provocative” concept, establish a force with capabilities to conduct “effective deterrence, resolute defense.” If the enemy were to activate intrusions, we will surely do our best to safeguard the nation.

III. Implementation Guideline of the National Defense Policies

1. Strengthen all-out defense

In this regard, the MND has to:

- (1) Effectively utilize human, material, and financial resources of the nation to support combat preparedness, and strengthen all-out defense capabilities, in accordance with the the policy of the “combination of national defense and the people’s livelihood,” which adopts the Constitution of the ROC as its foundation, military infrastructure as its core, economic infrasructure as its backdrop, and psychological infrastructure as its impulse.
- (2) Establish a national defense strength with natures of “omnidirectional development,” “participation of the people,” “integral defense” and “being trusted by the people.”
- (3) Promote operations pertaining to the implementation of the regulations for preparation of all-out defense mobilization.

2. Institutionalize National Defense Organizations

In this regard, the MND has to:

- (1) Uphold the concepts to nationalize the ROC Armed Forces:

Demand the ROC Armed Forces to live by principles of democracy, abide by the Constitution, refrain from undue deeds, transcend individual, regional, and partisan interests, and pledge loyalty to the nation and care for the people; ensure the ROC Armed Forces remain neutral and concentrate on its duties and combat preparedness so as to form a modernized professional military force.

- (2) Implement the National Defense Law and the Organization Law of the Ministry of National Defense:

Establish functions of “converging military administration system and military command system,” “civilian control of the military,” and “professional division of military administration, military command, and

military armament," in accordance with these two laws so as to focus the ROC Armed Forces' attention solely on combat trainings and preparedness.

3. Develop Modernized National Defense

In this regard, the MND has to:

- (1) Establish an excellent and modernized military force to best perform the concept of "effective deterrence, resolute defense;" devote itself to the rationalization of the organizational structure of the ROC Armed Forces.
- (2) Expand channels for recruiting personnel of talent; improve quality of its manpower; apply concepts of business administration to increase administrative efficiency.
- (3) Maintain the lead in defense technology and information & electronic warfare; enhance integration of weapon platforms of the ROC Armed Forces and efficiency of the joint operations; dedicate to developing autonomous defense technologies so as to create an efficient and modernized defense force.
- (4) Combine with the transformation of the ROC Armed Forces to refine the overall organization and structure of the current force.

4. Establish Crisis Management Mechanism

In this regard, the MND has to:

- (1) Cement the concept of "omnidirectional security," which stresses on increasing the capability to "react on emergency, make quick response and launch instant operations" to counter emergencies.
- (2) Establish risk and crisis management mechanisms for the ROC Armed Forces to cope with possible threats from terrorist activities or hostile unlimited warfare.
- (3) Response to the global anti-terrorism campaign and support the

government's policy to fulfill its duty as a member of international community.

5. Promote Regional Security Cooperation

In this regard, the MND has to:

- (1) Expand cultural and trade relations with international community in line with the government's policy; secure leeway for strategic alliance with friendly countries to assure the national survival and development.
- (2) Promote regional military exchange; seek military strategic cooperation with friendly countries, broaden the channels of military intelligence, prevent conflicts and lower the incidence of war.
- (3) Support the government's policy to pursue talks and exchanges with the Chinese Mainland to establish a military mutual trust mechanism, which is aimed at the transparentization of military conditions on the both sides so as to avoid misjudgments that lead to wars, and seek perpetual peace in the Taiwan Strait.
- (4) Coordinate the government's policy-implementation to actively promote regional security cooperation and interaction.

6. Implement the "Three Assurances" Policy

In this regard, the MND has to:

- (1) In aspect of guaranteeing safety for the forces: implement safety precaution measures; improve management mechanism; perform supervision functions; enhance psychological assistance to the forces so as to reduce unnecessary attritions and casualties in the ROC Armed Forces.
- (2) In aspect of giving servicemen a steady life: strive for legalization of servicemen's salary, wellbeing, preferential measures for dependents, and compensation for injuries or deaths on duty, so as to offer an well-founded caring mechanism for servicemen, and elevate their dignity and status.
- (3) In aspect of providing military dependents better living standard: en-

hance active correspondance and assistance to military dependents through interaction with them; provide them with more information or message from the military so as to comfort their worries.

IV. Military Strategies

1. Conceptual framework for defensive operations of the ROC Armed Forces

(1) Strategic conceptual framework

Based on the strategic conceptual framework of “effective deterrence, resolute defense,” at the onset of war, the defensive operations of the ROC Armed Forces shall adopt superior air and naval operations, selecting advantageous airspace and waters, to defeat incoming enemies in stages so as to ensure national security. The whole process of the operations will be coordinated with information, electronic, and special operations so as to disrupt and damage the operations and comat plannings of the enemy. Furthermore, the ROC Armed Forces will conduct operations to attack enemy’s key nodes of C⁴ISR so as to eliminate the enemy’s ability to launch its joint operations.

(2) Effective Deterrence

To pursue this effort, the MND has to:

- a. Establish an early warning system for war
- b. Set up a highly efficient mechanism and capability of joint operations
- c. Enhance offensive and defensive capabilities to conduct information and electronic operations
- d. Maintain air superiority and naval dominance; restructure a decisive ground force
- e. Improve capabilities to react on emergency, make quick response and launch instant operations
- f. Strengthen mobilization capability

g. Force the enemy into a status of “bewildering of uncertainty to win and heavy casualty” so as not to rashly invade Taiwan.

(3) Resolute Defense

To pursue this effort, the MND has to pursue:

- a. Information and electronic operations: protecting forces and defending enemies; utilizing hard-kill and soft-kill measures; inflicting key-node attacks
- b. Strategic durable operations (anti-ballistic missile): conducting active and passive defensive operations as well as C⁴ISR operations.
- c. Operations to command the air: securing surveillance and reconnaissance operations; combining counter-air operations; dogfighting timely.
- d. Operations to command the sea: countering blockades; maneuvering naval barricades; coordinating air and ground operations.
- e. Ground operations: keeping hostile unlimited warfare at bay; maintaining quick-reaction and maneuverability; defeating enemies in areas; counterattacking incessantly.
- f. All-out defense: establishing a all-out defense strength with natures of “omnidirectional development,” “participation of the people,” “integral defense” and “being trusted by the people.”

(4) Concepts of the use of force by the ROC Armed Forces

The concepts of the use of force by the ROC Armed Forces are as follows:

- a. Striving for superiority in information and electronic warfare and enhancing preempting and countering measures in order to dissolve the enemy’s attempts to seize electro-magnetic advantages during combat.
- b. Proposing responsive initiatives to counter hostile asymmetric operations, and actively establishing NBC protection capability.
- c. Acquiring and sustaining local air superiority in the Taiwan Strait in accordance with the guidance of integrated air-defense and counter-air operations, keeping awareness of hostile ballistic missile and aerial attacks so as to decrease attrition of the ROC Armed Forces in combat.

- d. Maintaining free passage of SLOCs via anti-blockade operations, and conducting mobile barricade operations in combination of aerial and naval assets as well as coastal firepower so as to defeat incoming enemy naval vessels, and win the dominance of the sea.
- e. Concentrating precision firepower of the ROC Armed Forces under the guideline of defeating incoming enemies and ensuring ground safety, combining air and ground mobile attack capabilities to defeat enemies on the beachheads and landing zones.
- f. Carrying out mobilization of reserves to help maintain a sustainable combat strength of the regular forces under the guideline of “regular forces responsible for front attacks, reserve forces for rear defenses.”

2. Conceptual framework for joint operations of the ROC Armed Forces

In the future, the force restructuring efforts of the ROC Armed Forces will focus on the improvement of “integrated capabilities of joint operations of the ROC Armed Forces.” The goal of the efforts is to establish an interoperable environment to share intelligence and information for the forces so as to grasp air superiority and sea dominance, and win the first battle. Once the enemy adopts full invasion with sea, air, and land forces, then the ROC Armed Forces, taking advantage of inherent barrier of the Taiwan Strait, will conduct operations to control the air, command the sea, and precede ground defense accordingly, so as to perform joint operations of the ROC Armed Forces to defeat the enemy in airspace and waters, which are beneficial for our defensive operations.

(1) Joint operations to command the air

“Automation of C², and establishing a precise air defense capability” are the goals to conduct joint operations to command the air. In line with the acquisition of the new generation aircraft, it’s imperative to enhance electronic warfare and early warning capabilities to improve the joint air defense operations.

(2) Joint operations to command the sea

“Adopting missiles as major shipboard weaponry, automation of C², conducting 3-Dimensional anti-submarine operations” are the goals to conduct joint operations to command the sea. It’s imperative to establish a naval capability to command the sea, which focuses on anti-blockade, anti-submarine, and naval barricade operations so as to maintain free passage of SLOCs both in peacetime and wartime.

(3) Ground defensive operations

“Mechanization, automation, and 3-dimension” are the goals to conduct ground defensive operations. It’s imperative to improve capabilities of ground surveillance and reconnaissance, mobile attacks, C², and logistic support so as to enhance overall strength of the ROC Armed Forces to defeat enemy on coastal areas.

3. Conceptual Framework for the Establishment of the Armed Forces**(1) Establishment of the armed forces**

Under the guideline of “obtaining information & electronic superiorities, keeping hostile unlimited warfare at bay, combining operations to command the air and the sea, ensuring ground operations, and defeating intruding enemy,” the MND is working hard to establish a compact but delicate, quick responsive, and highly efficient precision strike capability, so as to pose a strong posture of effective deterrence.

a. Guideline to acquire weapon systems

In line with the policy of “domestic built products as major consideration, foreign products as the supplement,” it’s imperative to promote R&D of defense technology to establish an autonomous defense industrial base for expanding sources for acquisition, and thus realizing the goals to modernize the ROC Armed Forces.

b. Guideline to restructure force mechanism

Under the principle of “lowering the amount of military personnel

but improving the quality of them, and enhancing overall combat capability,” it’s imperative to implement force refining program to fine-tune the force structure and to decrease the necessary amount of the ROC Armed Forces.

V. Organizational structure

1. The Ministry of National Defense

The MND is in charge of all the affairs pertaining to national defense. The Minister directs and oversees the national defense system formed by the three systems responsible for military administration, military command, and military armament. The Minister, considering the requirement of national defense, shall formulate defense policies and military strategies, organize a formidable military force, and fulfill defense missions.

2. Military administration system (MND HQs)

Under the minister, the military administration system is composed of 14 units, including Strategic Planning Department, Manpower Department, Resource Department, Legal Service Department, Judge Advocates Department, Reserve Affairs Department, Office of the Minister, Military History and Translation Office, Integration & Evaluation Office, Office of Inspector General, Appeal Committee, Council for Protection of Rights for Servicemen, Personnel Office, Accounting Office. Besides, there are (General) Political Warfare Bureau, Comptroller Bureau, Medical Bureau, Army GHQs, Navy GHQs, Air Force GHQs, Combined Logistic Command, Reserve Command, Military Police Command and the various military organizations (such as military academies, military courts and Inspection offices and military prisons) under the command of the Minister.

3. Military command system (The General Staff Headquarters, GSH)

(1) There are 7 staff-level units under this system, including Office of

Training & Doctrine Development for Joint Operation, Office of DCGS/personnel, Office of DCGS/intelligence, Office of DCGS/operation & planning, Office of DCGS/logistics, Office of DCGS/communication & electronics, and Office of Military Affairs.

(2) The military command system constitutes the minister's command staff units and is the command mechanism for joint military operations, responsible for identifying requirements for the establishment and combat readiness the ROC Armed Forces, making suggestions on the allotment of defense resources, overseeing armament preparedness, training troops, setting order of battle, drawing up plans for operations, and matters concerning military command to implement joint operations of the armed forces.

(3) Plans to conduct joint operation (including that of each service) are all conceived by the GSH. The acquisition of weapon systems for each service (including operational requirements) has to consider to perform joint operations, and is also planned by the GSH.

4. Military armament system (Military Armament Bureau)

(1) According to Legislative Yuan's additional resolution, "the MND can allocate necessary personnel to Military Armament Bureau in accordance with the prior authorized organization chart." Military Armament Bureau has 5 divisions, 3 offices, and 8 other staff-level units; furthermore, CSIST, Procurement Center, Engineering & Estate Center and Logistic & Production Center are also under the bureau's command.

(2) The military armament system constitutes the minister's armament staff units and is responsible for proposing policies regarding armament procurement, development of defense technology industries, technology exchanges and cooperation between military and private sectors and integrated logistics, etc., so as to fulfill the requirement of military

administration and command system.

5. General headquarters (GHQs) of three services (Army, Navy and Air Force)

The GHQs of three services of the ROC Armed Forces fall under the jurisdiction of the MND, in charge of the implementation of military administration and armament affairs. They are responsible for the basic and specialized training of subordinate military units, as well as the maintenance and preparedness of armament. Pursuant to the orders of the minister, these three services and their relevant agencies constitute the backdrop for the GSH to conduct its command demands.

6. Organizational Chart of the Ministry of National Defense (Table 2-1)

Table 2-1 Organizational Chart of Ministry of National Defense

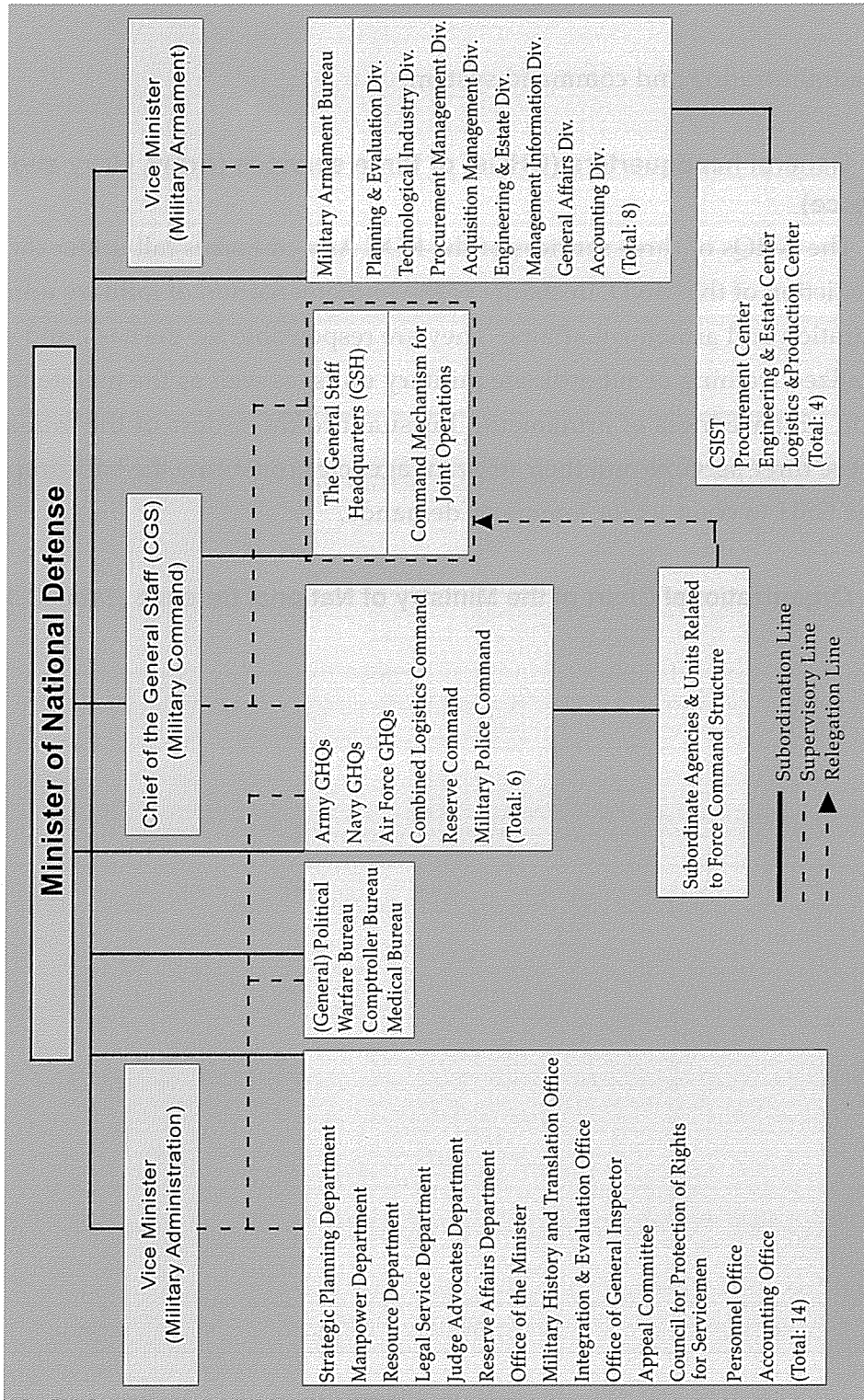

Objectives for Force Restructuring

Under the strategic guidance of “effective deterrence, resolute defense,” currently, the modernization of the Armed Forces and restructuring of each service are the focal points of the restructuring efforts undertaken by the MND. Each service will concentrate on developing of capabilities with its own characteristic so as to improve the Armed Forces’ comprehensive capabilities to conduct joint operations.

1. ROC Army

Major objectives include enhancing automation of C², adopting 3-dimensional operations, and mechanizing military equipment. In order to pursue these objectives, the ROC Army has to:

- (1) Develop information and electronic warfare system and elevate the



Establish Anti-aircraft Missile Systems to Boost Air Defense Capability

efficiency of battlefield management, under the integrated guideline for conducting joint operation of the ROC Armed Forces.

(2) Improve tangible and intangible combat capabilities ranging from reconnaissance, mobility, C², supply, strike, and morale.

(3) Build air defense missile batteries to improve overall air defense capability.

(4) Combine operations of using helicopter and armored vehicles to integrate ground and air defense.

(5) Install new types of self-propelled artillery, rockets and anti-armor weaponry to strengthen firepower of ground forces.

(6) Acquire wheeled, tracked, and armoured vehicles to improve ground defense capability.

2. ROC Navy

Major objectives include enhancing automation of C², adopting 3-dimensional approach to conduct anti-submarine operations, and adopting missiles as major shipboard weaponry. In order to pursue these objectives, the ROC Navy has to:

(1) anti-submarine, mine-deploying and minesweeping capabilities Enhance 3-dimensional information and electronic warfare system in line with joint operation system of the ROC Armed Forces so as to improve overall air defense operations and countermeasure capabilities.

(2) Construct a new generation of battle ships, destroyers, large fast attack missile boats to secure the command of sea, form an effective mobile surface force, and strengthen anti-blockade capability of the ROC Navy.

(3) Construct a viable submarine force and acquire submarine-launched weapon; improve aerial anti-submarine, mine-deploying and minesweeping capabilities; strengthen 3-dimensional anti-submarine, mine-deploying and minesweeping capabilities.

(4) Improve deployment coastal firepower, strengthen post defense, and



Enhancement of Coastal and Post Defenses

reinforce sea control.

(5) Continue acquiring air defense and anti-armor weaponry as well as mechanical equipment for Marine Corps so as to increase its capabilities of quick response and restoration warfare.

3. ROC Air force

Major objectives include enhancing automation of C², and improve attacking precision. In order to pursue these objectives, the ROC Air Force has to:

(1) Develop long-range reconnaissance capabilities, and build up a comprehensive radar intelligence network to increase early warning timespan and develop early warning and counterattack capabilities of surface-to-surface missiles in line with joint operation system of the ROC Armed Forces.

(2) Acquire and improve surveillance & reconnaissance, and electronic



Establishment of a Strong Tactical Air Force to Attain Air Superiority

warfare capabilities so as to effectively support combat operations.

(3) Improve air defense operations of “precise engagement;” using Automated C² system as its core, integrate Recce aircraft, AEW aircraft, EW aircraft, high performance fighters, and anti-air artillery (AAA).

(4) Establish a tactical air force with a new generation of aircraft to obtain air superiority, and join with the other services to carry out anti-blockade and anti-landing operations.

(5) Integrate various AAA weapon platforms so as to boost the efficiency of joint air defense operations.

4. Combined Logistics Command

Major objectives include adoption of management of enterprise and automated production. In order to pursue these objectives, the Combined Logistics Command has to:

(1) Promote using information management system and improve mate-

rial management to upgrade quality and lower cost.

(2) Establish automated production line, improve productivity and quality, lower costs so as to elevate manufacturing capability of weapon, equipment and munitions up to global standard.

(3) Improve existing weapon systems and develop new ammunition to increase self- production capability.

(4) Develop special materials to improve protection of the military personnel.

(5) Develop precision materials and components to enter global market.

5. Reserve Command

Major objectives include digitalization of mobilization management, and refining reserve forces. In order to pursue these objectives, the Reserve Command has to:

(1) Establish comprehensive management information system and communication network in line with the planning of electronic warfare system of the ROC Armed Forces.

(2) Adjust organizational structure, and improve civil defense and mobilization, management, training and service of reservists.

(3) Inspect and complete the distribution of weapons to reserve force so as to establish fundamental combat capabilities of reserve forces.

(4) Enhance mobilization activities, commissioning process of reservists, and speed of restoration of combat power to increase the combat readiness of mobilization.

(5) Set up mobilization warehouse and training bases for reservists to refine their combat capabilities.

(6) Establish a centralized image database of reservists to improve the management of information on them.

6. Military Police Command

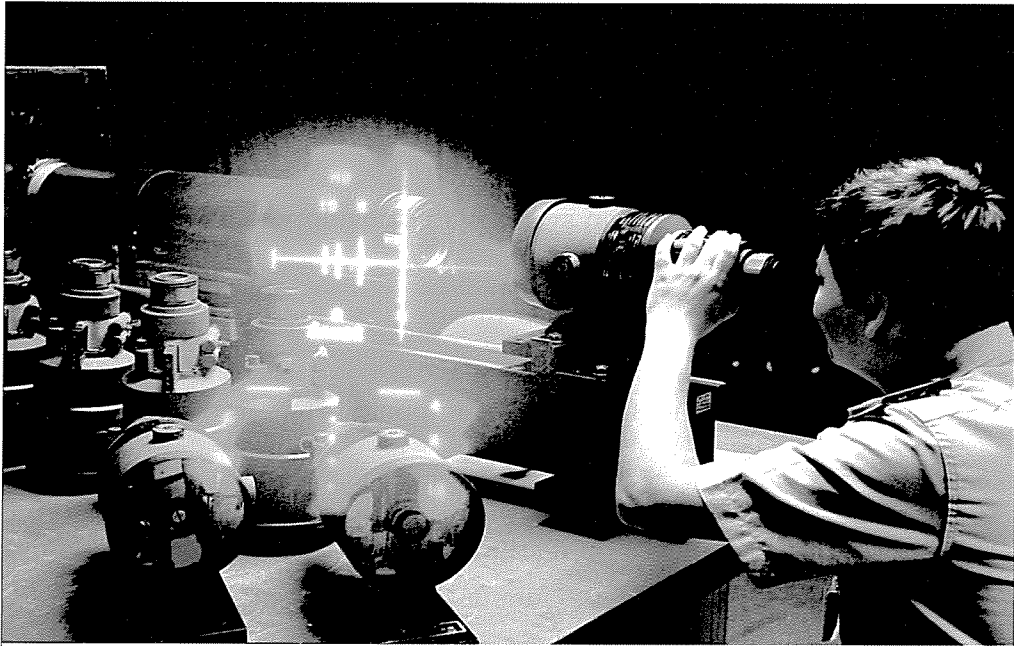

Develop Precision Material and Upgrade R&D Capabilities

Major objectives include automation of C², and mobility, the digitalization of security measures. In order to pursue these objectives, the Military Police Command has to:

- (1) Develop comprehensive information operating system and update communication equipment to improve its C⁴ISR capabilities.
- (2) Enhance capabilities of mobility, strike, protection, and preventing & handling rallies.
- (3) Construct precise, light and fast armament, and provide sufficient supplies of specialized equipment and mobile vehicles for the purpose of surveillance, evidence collection, inspection, explosion prevention and security and protection.
- (4) Improve NBC equipment to enhance its defense and protection.

PART THREE
NATIONAL DEFENSE RESOURCES

Summary

1. The ROC Armed Forces, in enforcing its streamlining policy, aims to build a modernized military force that is "compact, delicate, and highly capable." Based on this principle, the MND shall make timely review on updating the criteria for disqualifying conscripts and setting higher standards in physical conditions for new conscripts. By filtering out the unsuitable and unqualified conscripts, the quality of servicemen will be significantly improved.
2. Owing to the dwindling national defense budget of the ROC, skyrocketing personnel expenses and maintenance costs of the next-generation weapons, the course of the force restructuring has been thus greatly affected. In contrast, the national defense budget for the PRC has grown by 283.83% in the last decade. The MND earnestly hopes that while the government strives to achieve the steady expansion of national economy, it may keep the national defense budget on a reasonable level to achieve the goals of maintaining combat readiness and ensuring national security.
3. The national defense technological policies of the ROC are: to delegate the capacity of defense technology to private sectors by widely cooperating with related industries, government, academia and research institutes; to continue improving the capacity of R&D of defense technology and critical weapon systems to achieve the goal of autonomous national defense; to observe international conventions and government policies by upholding the principles of "no-obtaining, no-producing, and no-fielding of NBC weapons."
4. In line with government's free trade, internationalization, and civil supervision policies, the MND will establish a legalized, transparentized, fair, and reasonable acquisition environment. Pursuant to the Government Procurement Law and related regulations, the acquisition principles of the ROC Armed Forces are as follows: 1) considering domestic products first, and 2) procuring products from diversifying regions of production.

5. In order to satisfy the needs for national economic development, and make the best of military properties, the MND will assess the utilization of its land properties on the premise of without impact on the its combat readiness status. The policies in this regard are "merging smaller barrack compounds with large ones," "moving barracks and training sites from urban areas to slight mountain slope areas or suburban areas." In line with these policies, the MND will release empty or waste barrack compounds to public usage.

National Defense Manpower

I. Objectives and Policies

In line with national goals and requirements for social and economic developments, as well as its strategic concepts and guidance, the MND will thoroughly analyze its national defense manpower in the hope of exploiting credible human resources, cultivating capable military cadres, and allocating military personnel properly and efficiently so as to maintain a constant and reasonable military force in peacetime, perform mobilization capacity in wartime, and thus reach the goal to maintain national security.

Considering the fluctuation in international environment and domestic political and economic situations, the ROC Armed Forces has been working hard to fine-tune its national defense manpower policies accordingly. These manpower policies, in concert with efforts of restructuring the national defense organs, adjusting national defense strategies and replacing obsolete weapons, aimed at properly streamlining national defense manpower, enhancing the quality of military personnel, and establishing a “compact but delicate, highly capable” and modernized military force.

II. Quality and Age Structure of Servicemen

The ROC Armed Forces, in enforcing its streamlining policy, aims to build a modernized military force that is “compact, delicate, and highly capable.” Based on this principle, the MND shall make timely review on updating the criteria for disqualifying conscripts and setting higher standards in physical conditions for new conscripts. By filtering out the unsuitable and unqualified conscripts, the quality of servicemen will be significantly improved (Figure 3-1).

With the prevailing of secondary and high level education nationwide, the educational level of the servicemen is also rising. According to the data of

Figure 3-1 Percentage Comparison of Different Servicemen, 2000

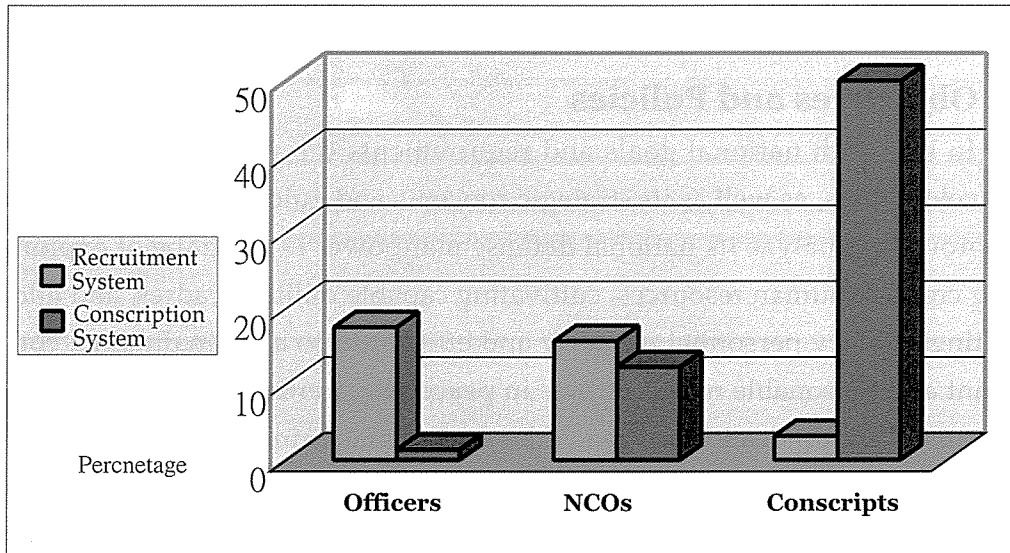

Education Status Analysis of the ROC Armed Forces in 2001 (Figure 3-2), there is 84.8% of the total number with the educational level of senior high school and above, and 43.66% with college and above (including graduate school).

According to the age structure of year 2001, the average age of servicemen is 25.2, among them, 31.31 for officers, 24.72 for NCOs, and 22.01 for conscripts (Figure 3-3).

As for the female military personnel, current percentage of female officers is 4%, and 3.1% for female NCOs. The employment of female manpower has shown significant effectiveness in promoting the overall combat capability.

Basically, young and highly educated are the distinctive characteristics of present servicemen. Thus, after joining the active service with complete military training, this high-quality manpower will dramatically enhance the military buildup and combat readiness of the ROC Armed Forces.

Figure 3-2 Education Status Analysis of the ROC Armed Forces, 2001

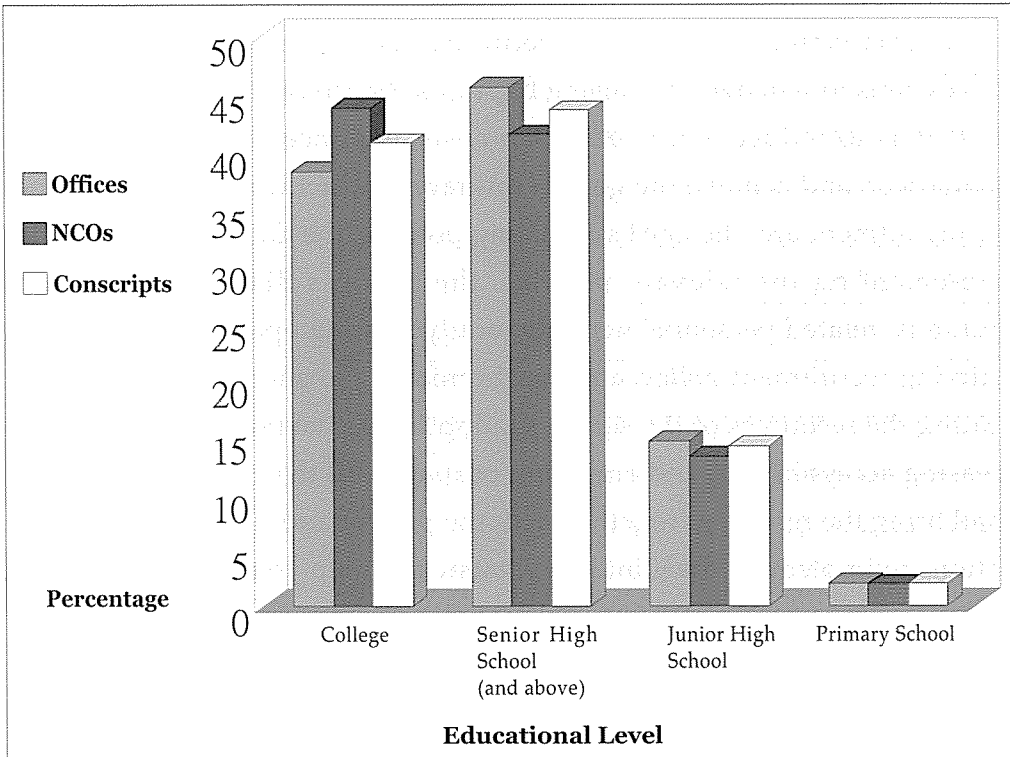
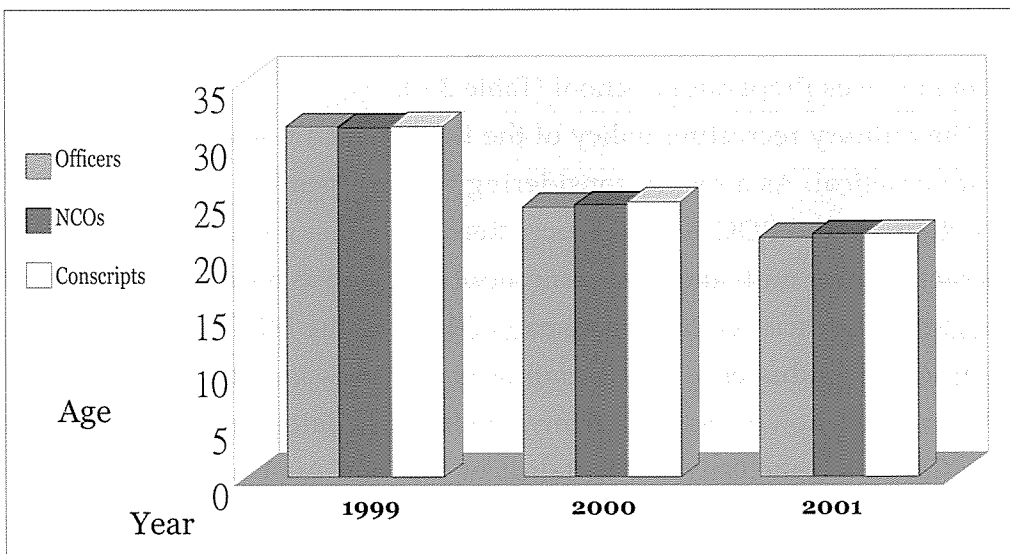

Figure 3-3 Average Age Comparison of the ROC Armed Forces, 1999-2001



III. Recruitment

By establishing a specialized recruiting organization, the ROC Armed Forces aims to win over promising high-quality candidates to join the military so as to reduce extra education costs, enhance the performance of manpower, and achieve the goal of military restructuring. The guidelines for recruitment are: the GSH stipulating policies, the GHQs of each service implementing the relevant policies, the services dispatching liaisons mutually, related personnel working jointly, sharing operational resources, unifying recruitment policy, and synchronizing the pace of action. By integrating the resources of the services, adopting active marketing policy, increasing accessibilities and enriching propaganda, the ROC Armed Forces shall bring the resources together with the private and government organizations to implement the joint recruitment and help young people gaining comprehensive information for a prospective military career.

Currently, there are 13 military recruiting programs, including Regular Class (academy), Technical Class (junior college), Professional Female Officer (NCO) Class, Specialized Officer (NCO) Class, Regular NCO Class, Navy Petty Officer Class, Air Force Professional Flight Class, Junior College for Sergeants, Reserve Officer Training Corp (ROTC) and Chung-Cheng Armed Forces Preparatory School (Table 3-1).

The military recruiting policy of the ROC Armed Forces will tend to be more practical. As a result, considering the necessary scale of manpower distribution, the ROC Armed Forces needs to enlist more high-quality career recruits for mid- and long-term service, as well as a small proportion of short-term conscripts. In a time span of 3 years, the MND plans to recruit high school graduates to join the military, and be assigned in the Motorized Infantry Battalion of the ROC Army, the Infantry Battalion of the ROC Marine Corps and the Garrison Battalion of the ROC Air Force to run experimental career recruits program. The MND will annually conduct reviews on this program. If the result turns out to be fine, this program will not only

go on, but also increase the scale of career recruits. By the time, it's planned that the proportion of conscription will decrease to 40%, and pursuing recruitment system will become the primary source to enlist personnel with conscription system as a supplement so as to meet the requirement of all-out mobilization in wartime and accomplish missions to ensure the national security.

IV. Vision

While planning the application of national defense manpower, the MND

Table 3-1 Enrollment Statistic Data from 1999 to 2001

Items		Regular Class (Academy)	Technical Class (College)	Chung-Cheng Armed Forces Preparatory School	NCO Class	Female NCO Class	Specialized Officer Class	Specialize NCO Class	Total
1999	Required number	1,467 (78)	2,772	605	4,556	186	1,612	6,478	17,685
	Applie nuber	18,864		3,103	8,380	6,742	1,674	11,241	50,004
	Passed number	1,231 (70)	1,102	528	2,626	133	967	4,707	11,294
	Enrollment Rati	83%	49%	87%	58%	72%	60%	73%	64%
2000	Required number	1,367 (89)	1,866	600	2,769	191	1,797	7,985	16,575
	Applie nuber	15,801		2,971	6,059	5,736	2,246	14,229	47,042
	Passed number	1,181 (84)	1,200	547	1,415	144	1,515	5,973	11,975
	Enrollment Rati	86%	64%	91%	51%	75%	84%	75%	72%
2001	Required number	1,376 (106)	1,713	575	2,823	304	2,063	5,928	14,782
	Applie nuber	20,088		2,706	8,865	7,816	6,967	21,909	72,015
	Passed number	1,099 (84)	1,563	516	2,319	226	1,036	4,067	10,826
	Enrollment Rati	80%	91%	90%	82%	50%	50%	69%	73%

shall consider the factors of military development and force restructuring, as well as the demands of national comprehensive development to make the most efficient allocation and application of manpower. Regarding future application of national defense manpower, the MND will devote itself to improving working environment for military personnel, maintaining a rational salary standard, elevating the social status of servicemen and utilizing recruiting institutions to expand the military manpower resources. Besides, in order to realize its streamlining policy, the MND will adjust the structure of the ROC Armed Forces and expand its sphere to utilize civil resources so as to supplement the regular military force. Furthermore, the specialty of every military personnel will be properly utilized so that servicemen can truly plan their individual military career, which may best perform their specialty. The MND will do its best to fine-tune its requirements for manpower, eliminate unnecessary personnel by coordinating force restructuring and weapon upgrading efforts, as well as using scientific methods.

National Defense Funding

I. Objectives and Policies

There are many concerns involved in the formation of national defense funding policies: the overall national economic development, governmental financial capability, national security, as well as budgetary system of the ROC Armed Forces. The objectives of the policies are to effectively support combat readiness and achieve the defined national defense goals. The guidelines of the policies include three domains: budget acquiring and planning, budget distribution and allotment, and budget management and assessment.

1. Budget acquiring and planning: Complying with the mid- and long-term Planning, Programming and Budgeting System (PPBS), the mid-term budget-line appropriated by the Executive Yuan, the priorities of military buildup and preparedness, and the principle of “planning after the acquiring budget,” the MND will complete the mid-term budgetary administration plan, which will be submitted to the Executive Yuan for auditing, so as to refine the mid-term plan for national defense funding.

2. Budget application and allotment: In line with the PPBS of the ROC Armed Forces and the defense budget-line appropriated by the Executive Yuan, the MND will satisfy primarily the budget demand for the obligatory expenditure, continuously fulfill the basic budgetary needs of living, operating, exercising and training in the military, and strive for increasing the budget for maintaining the combat readiness of the ROC Armed Forces. Furthermore, the MND will annually complete the budgetary plans for military investment in R&D, producing and procuring of advance weaponry and equipment so as to support military operations in due course.

3. Budget management and assessment: Based on the concept of the military buildup and restructuring program of the ROC Armed Forces, the MND will follow the procedures of 5 years policy-implementation plan to fine-

tune its annual budgetary planning activities. Once the budgetary plan is done, the MND will supervise the implementation of the budgetary plan on a monthly basis. In addition, a special mechanism of fund management will also be established to supplement defense budgetary activities.

II. Acquisition and Planning of National Defense Budgets

1. The Proportion of Defense Budget in Total Government Budget and GNP (Figure 3-4)

Owing to increased budget demands for development of a diversified society, social welfare and overall national economic development, the proportion of national defense budget in total government budget has dropped annually from 25.32% in 1993 to 17.19% in 2002. (The proportion of actual

Figure 3-4 The Proportion of Defense Budget in Total Government Budget and GNP, FY1993-2002

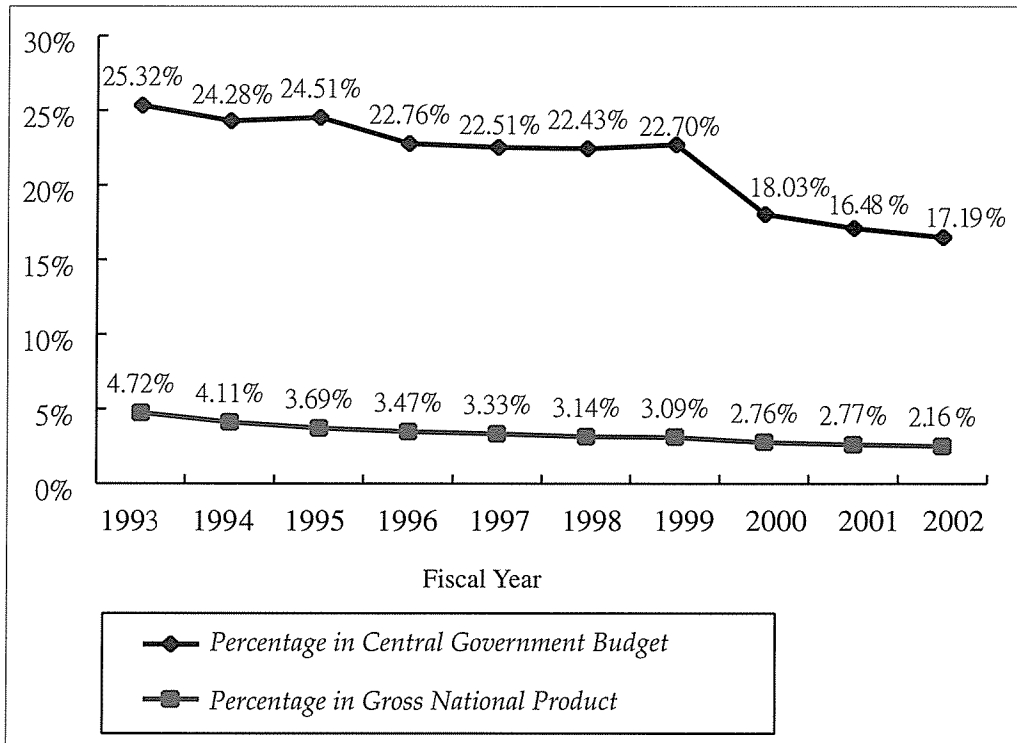

Note: The defense budget for FY2000 is for 18 months

national defense budget in total government budget will be 16.53% after deducting NT\$ 10.02 billion earmarked for the compensation fund of unfair verdict in the cases on treason and espionage during the Martial Law Period, Ding-yuan Project and Xiang-sheng Project.) In addition, the proportion of defense budget in GNP also dropped from 4.72% in 1993 to 2.61% in 2002. (The practical defense budget accounts for only 2.51% of the GNP.)

2. Comparing the growth rates between total government budget and national defense budget (Figure 3-5)

The total government budget was NT\$ 1,070.71 billion in FY 1993, and NT\$ 1,518.72 billion in 2002, which was increased by NT\$ 448 billion. The

Figure 3-5 Comparison of the Growth of Total Central Government Budget and Defense Budget, FY 1993-2002

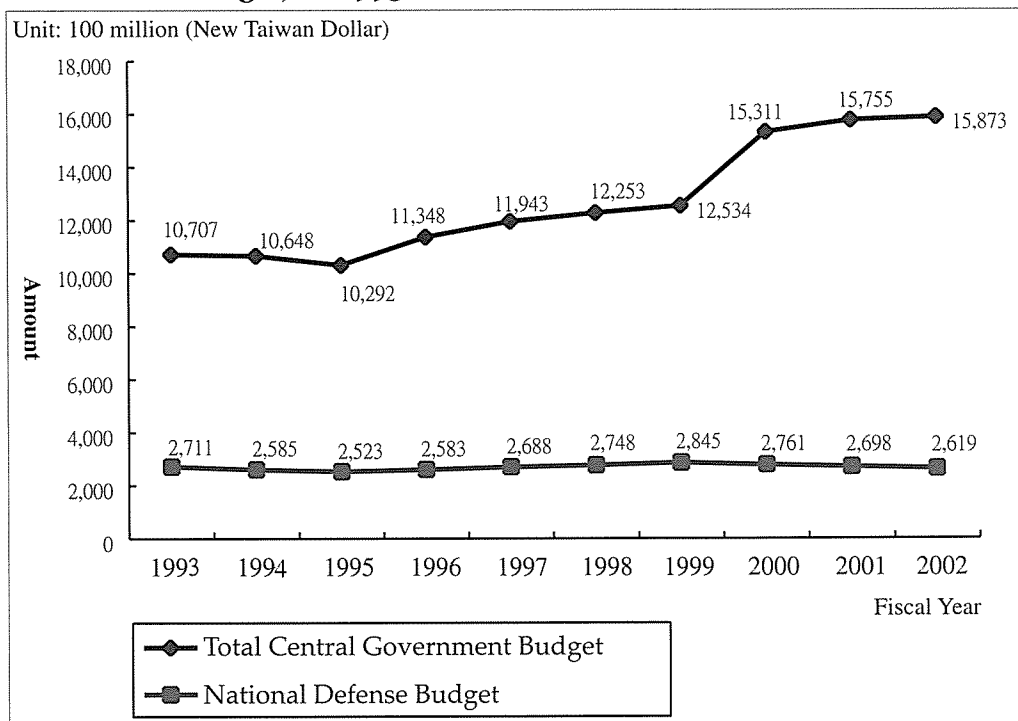

Note: The defense budget for FY2000 is for 18 months, and the data of FY2000 shown here is calculated for 12 months for the sake of comparison (the data is divided by 1.4596 stipulated by the Executive Yuan).

growth rate is 41.84%. However, the national defense budget was NT\$ 271.09 billion in FY 1993, and NT\$ 261.04 billion in 2002, which was decreased by NT\$ 10.04 billion or 3.70%.

3. The proportion of unclassified and classified defense budget (Figure 3-6)

Due to the democratization and pluralization of our society in recent years, the transparentization of national defense budget has been required to satisfy people’s right to know. In response to such global trend, the MND has specified Guidelines for the Classified Budgeting of the MND under Implementation Regulations for the Protection of State Secret and Guidelines for the Categorization Scope of Military Secret to distinguish unclassified and classified budget in line with people’s right to know and national security. The classified budget accounted for 61.17% of the total national defense budget in FY 1993 and 17.67% in 2002 with a sharp drop of

Figure 3-6 The Ratio of Unclassified and Classified Defense Budget, FY 1993-2002

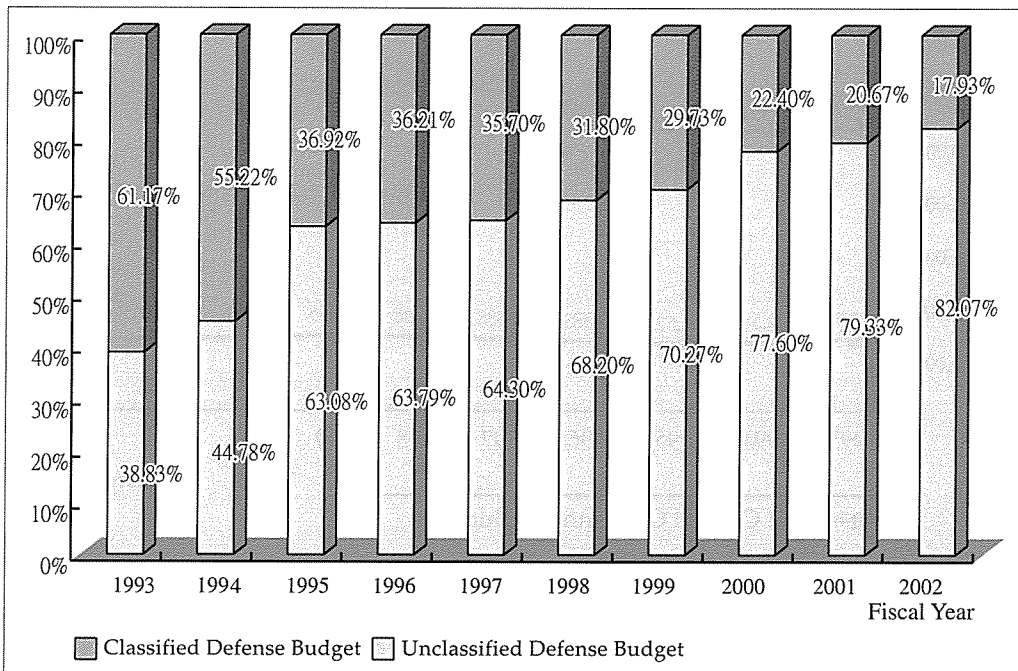

of 43.50%. The data have indicated the practical effectiveness achieved by the MND in striving to speed up the transparentization of defense budget.

The national defense budget indicates not only the planning of military buildup and combat readiness, but also a significant symbol of national defense implementation, which involves procurement, R&D and production of armament; the construction of military facilities; training of military personnel; and so forth. According the trend analysis of the steady decreasing proportion of national defense budget in total government budget and GNP, and the sluggish or even negative growth of national defense budget in the last decade, the impact on national defense policy-implementation resulted from the continuous tightening of defense budget needs more attention. However, the fact that the proportion of classified defense budget in total national defense budget is decreasing has indicated the effectiveness achieved by the MND in striving to speed up the transparentization of defense budget. It's expected that through these efforts a mutual trust mechanism between two sides of the Taiwan Strait can thus be established.

III. Allotment and Utilization of National Defense Budget

National Defense Budget allotment and utilization in 2001 and 2002 are as follows:

1. The MND Budget of FY 2001

The budget for annual expenditure managed by the MND for FY 2001 is NT\$ 269,753,546,000. The budget allotment is outlined as follows:

- (1) The budget items for annual expenditure in Operation Manual for Central Government Budget Planning are categorized as follows: (Figure 3-7)
 - a. National Defense outlay: The expenditures made for the MND and its subordinate units and agencies on equipment, military infrastructure, construction, facilities, military administration expenses, political warfare, education and training, intelligence, communications, supply and maintenance, logistical support, and personnel expenses of a like nature.

Figure 3-7 Budget Items of National Defense Budget in FY 2001

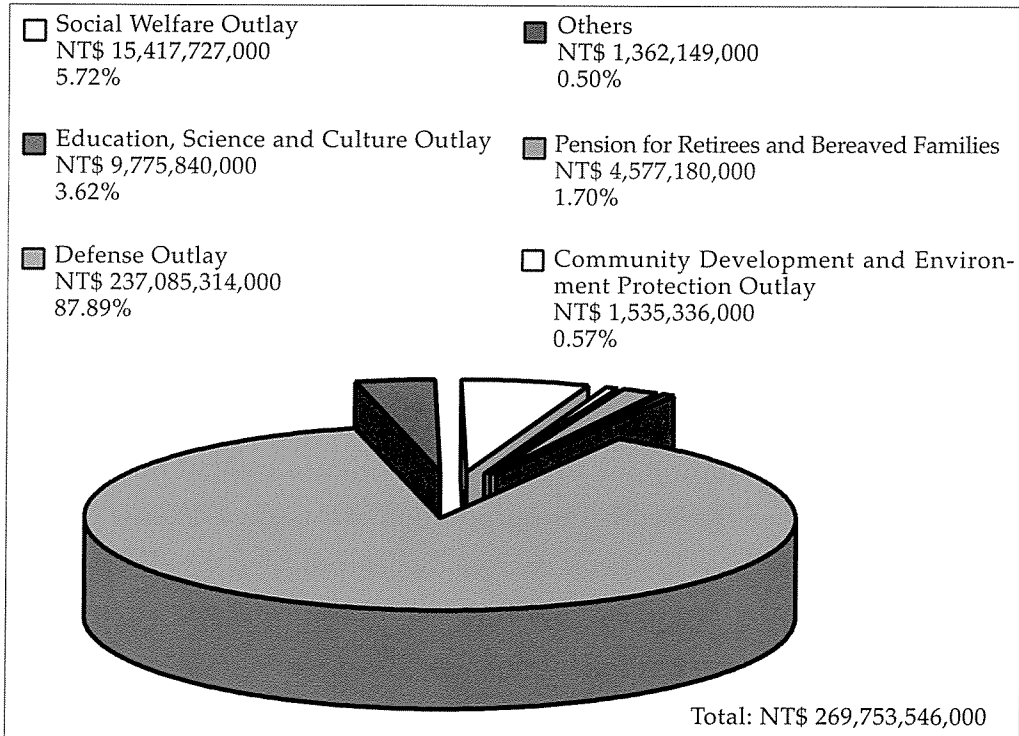

b. Education, science and culture outlay: It is made for scientific research equipment and related needs.

c. Social welfare outlay: This includes group insurance for officers, laborers, civilian employees, and the supplementary funds for the National Insurance Program as well as the compensation fund for unfair verdict in cases on espionage during Martial Law period.

d. Community development and environment protection outlay: The term includes expenses for environmental protection and a fund for housing loans for servicemen.

e. Pension for retirees and bereaved families: The pension fund and allowances are earmarked for the retirees and the bereaved and operating expenses.

f. Other outlays: Including various allowances for military dependents.

(2) The categories of national defense budget allotment by units and services. (Figure 3-8)

a. The MND HQs: The total budget for the MND HQs is NT\$ 29,525,000, and this budget is used for national defense administration, policy research, the operations of strategic planning and integrated evaluation in accordance with Organization Law of the MND.

b. Organic units under the MND: The total budget of NT\$ 269,458,291,000 for the Army, the Navy, the Air Force, the Combined Logistics Command, Corps Control Area Command and the subordinate units of the GSH accounts for 99.89% of total national defense budget in 2001. It's expected that after acquiring their respective budget, they can focus their attention on enforcing the streamlining policy, improving capabilities of surveillance & reconnaissance, enhancing strength to command of the air and the sea, restructuring ground defense operations, and completing the mobilization operations as well as improving ef-

Figure 3-8 Defense Budget Sharing Structure by Component, FY 2001

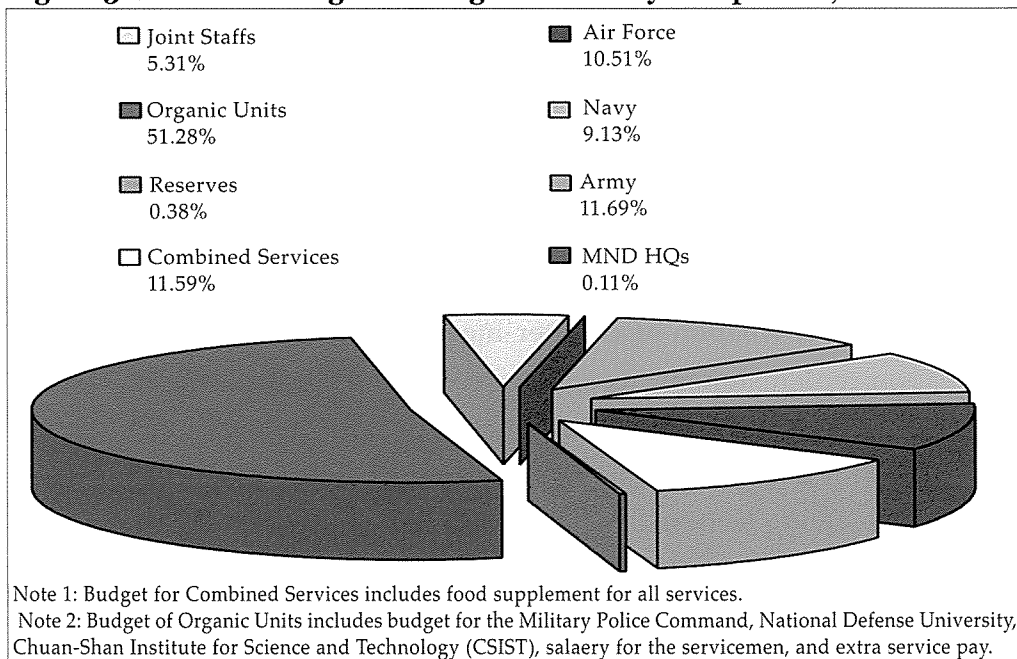
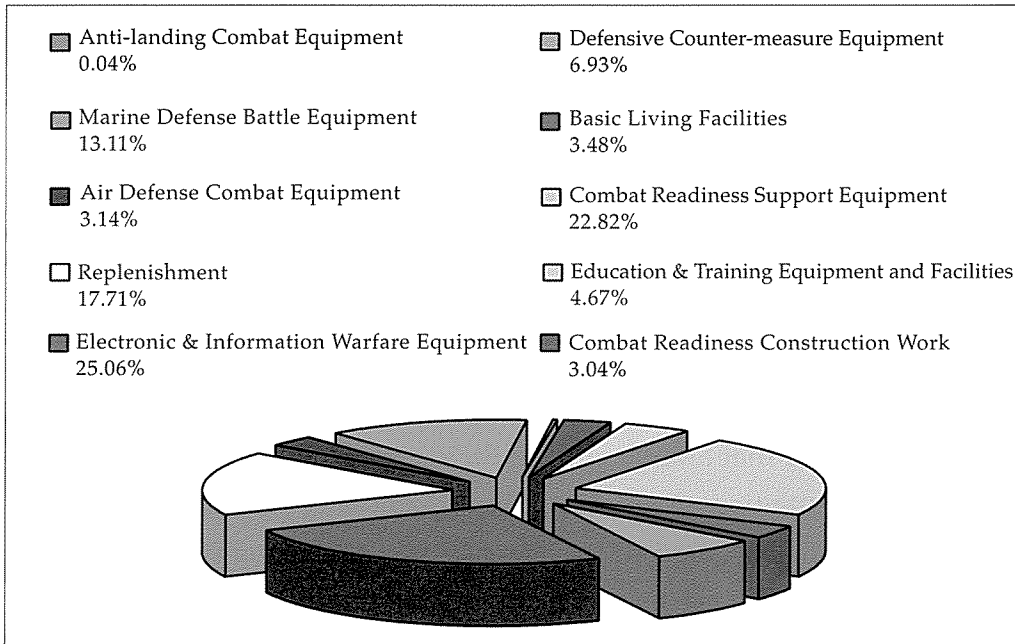

Figure 3-9 Structure of Military Investment of National Defense Budget, FY 2001



forts on R&D and production of weapons and equipment. In addition, this portion of budget also covers the informationalization of military operations, comprehensive logistic support and rebuilding of old military dependents' quarters so as to achieve the designated goals of national defense policy-implementation.

(3) The national defense budget for the production, R&D and procurement is around NT\$ 62.7 billion (Figure 3-9). It is based on 10 categories of military investment including equipment for electronic and information warfare, weapon of counter-measure and defensive operations, weapon replenishment, weapon to command the air, weapon to command the sea, weapon to conduct ground defense, military infrastructure, facilities for military education and training, combat support equipment, and basic living facilities.

2. The MND budget of FY 2002

The budget for annual expenditure managed by the MND for FY 2002 is NT\$ 261,047,345,000. The budget allotment is outlined as follows:

(1) The budget items for annual expenditure in Operation Manual for Central Government Budget Planning are categorized as follows: (Figure 3-10)

- a. National Defense outlay: The expenditures made for the MND and its subordinate units and agencies on equipment, military infrastructure, construction, facilities, military administration expenses, political warfare, education and training, intelligence, communications, supply and maintenance, logistical support, and personnel expenses of a like nature.
- b. Education, science and culture outlay: It is made for scientific research equipment and related needs.
- c. Social welfare outlay: This includes group insurance for officers, laborers, civilian employees, and the supplementary funds for the National Insurance Program as well as the compensation fund for unfair

Figure 3-10 Budget Items of National Defense Budget, FY 2002

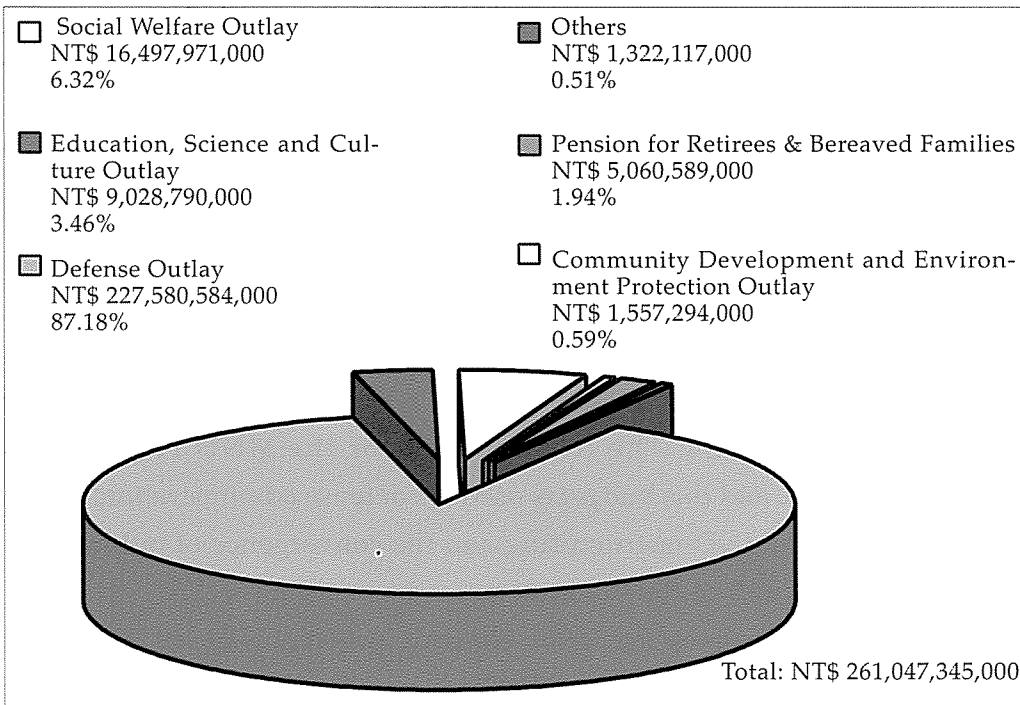
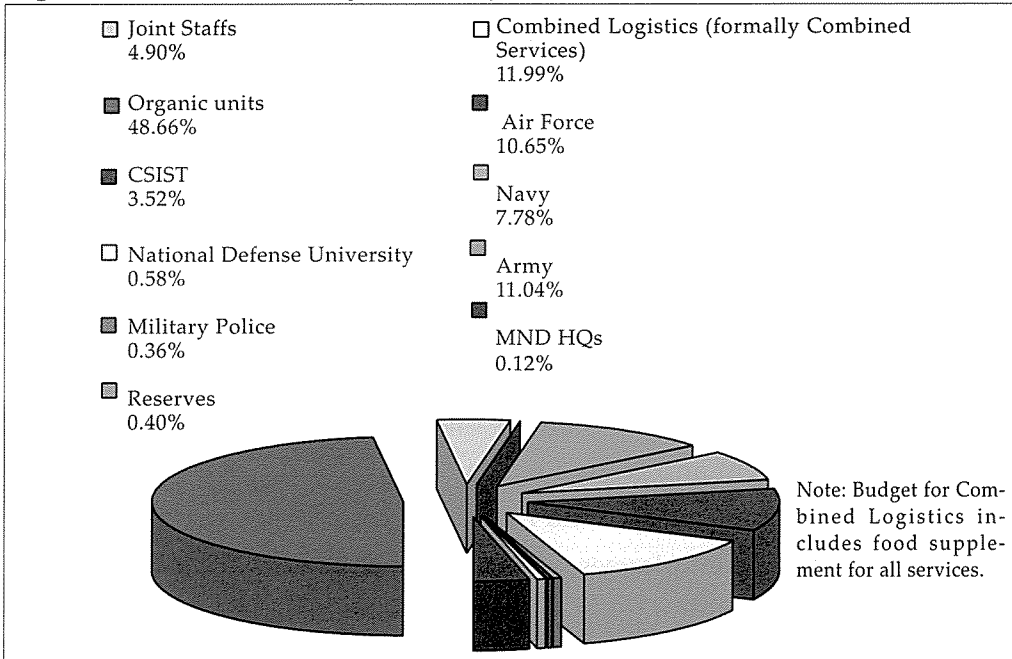

Figure 3-11 Defense Budget Sharing Structure by Component, FY 2002



verdict in cases on espionage during Martial Law period.

d. Community development and environment protection outlay: The term includes expenses for environmental protection and a fund for housing loans for servicemen.

e. Pension for retirees and bereaved families: The pension fund and allowances are earmarked for the retirees and the bereaved and operating expenses.

f. Other outlays. Including various allowances for military dependents.

(2) The categories of budget allotment by units and services. (Figure 3-11)

a. The MND HQs: The total budget for the MND HQs is NT\$ 318,762,000, and this budget is used for defense administration, policy research, the MND restructuring and the convergence of military administration and command system.

b. Organic units under the MND: The total budget of NT\$ 260,728,583,000 of the organic units under the MND accounts for 99.88% of total defense

budget in 2002. It's expected that after acquiring their respective budget, they can focus their attention on upgrading the ROC Armed Forces' comprehensive capabilities to conduct information operations, improving C⁴ISR integration and joint operational trainings, completing the mobilization operations, developing key defense technologies, establishing Integrated Logistic System (ILS), rebuilding of old military dependents' quarters so as to achieve the designated goals of national defense policy-implementation.

(3) The budget for the production, R&D and procurement is around 55 billion NT dollars (Figure 3-12). It is based on 10 categories of military investment including equipment for electronic and information warfare, weapon of counter-measure and defensive operations, weapon replenishment, weapon to command the air, weapon to command the sea, weapon to conduct ground defense, military infrastructure, facilities for military education and training, combat support equipment, and basic living facilities.

Figure 3-12 Categories of Military Investment of National Defense Budget, FY 2002

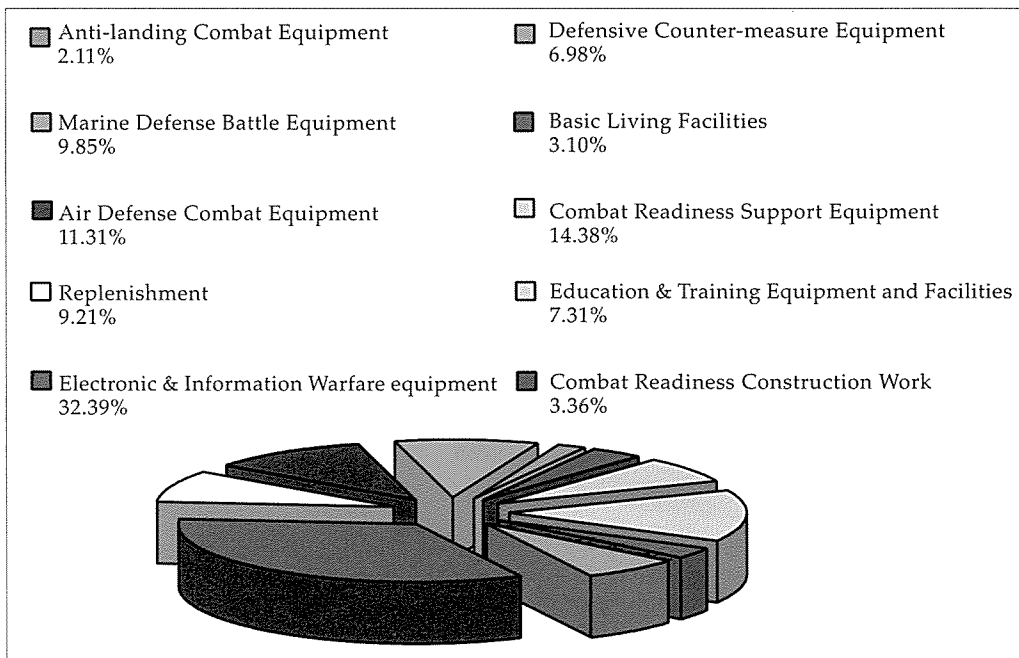

IV. Management and Supervision of National Defense Budget

1. National defense budget execution in the second half of FY 1999 and FY 2000 (Figure 3-13)

The national defense budget for annual expenditure managed by the MND for the second half of FY 1999 and FY 2000 was NT\$ 403,067,978,000. The audited payment is NT\$ 351,204,360,948. The accrued expenditure is NT\$ 41,222,787,641. The final accounting is NT\$ 392,427,153,589. The remaining balance is NT\$ 10,640,824,411.

2. National defense budget execution in FY 2001 (Figure 3-14)

The national defense budget for annual expenditure managed by the MND for FY 2001 is NT\$ 269,753,546,000. The audited payment is NT\$ 230,895,078,916. The accrued expenditure is NT\$ 35,282,299,034. The final accounting is NT\$ 266,177,377,950. The remaining balance is NT\$ 3,576,168,050.

V. Vision

For the sake of fulfilling military strategic requirements (financial needs) and reaching designated goals of national defense budgetary operations with limited national defense resources (financial supply), it is extremely important for the ROC Armed Forces to construct a prediction model to properly

Figure 3-13 Budget Execution in the Second Half of FY 1999 and FY 2000

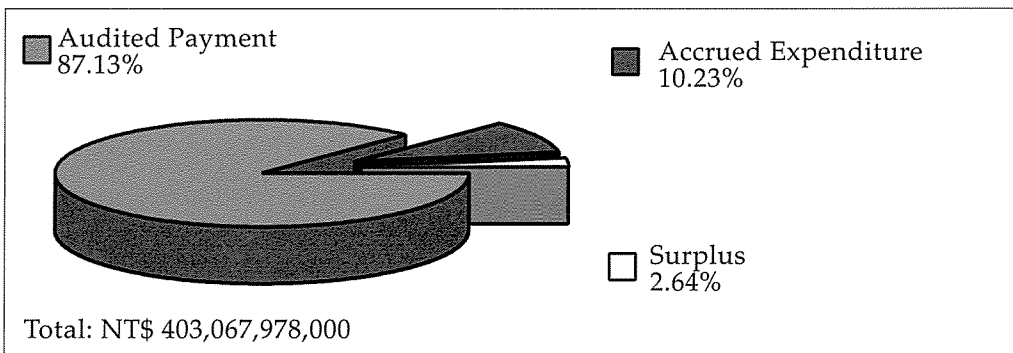

Note: The defense budget of FY2000 is for 18 months, dated from July 1, 1999 to December 31, 2000 in accordance with the amendment of the Budget Law.

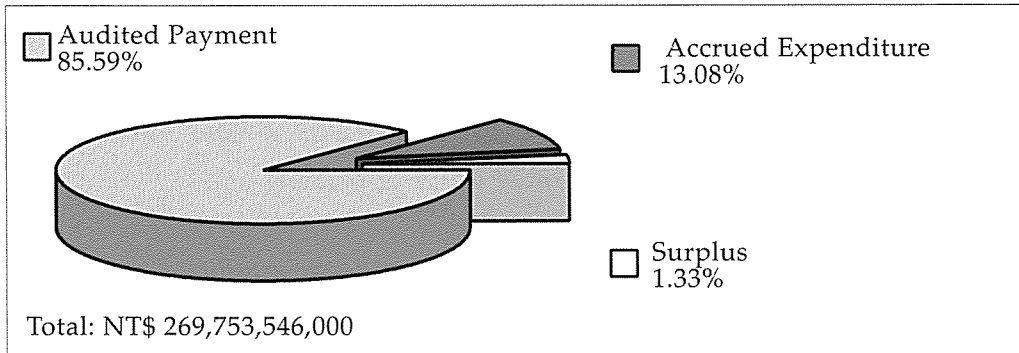
Figure 3-14 Budget Execution in FY 2001

manage national defense financial resources, and truly aware of financial supply at hand so as to timely assist in maintaining combat readiness of the ROC Armed Forces.

1. Constructing a prediction model to properly manage national defense financial resources

Concerning that the governmental mid- and long-term comprehensive policy-implementation goals have to meet the sustainability of overall national budget, the Executive Yuan is working hard to prevent its programs from overly expanding. Since 2002, it has been especially setting spending caps on the projected mid-term annual expenses of its subordinate ministries and agencies so as to properly regulate the allotment of budget. However, the ROC Armed Forces must deal with myriad of complicated tasks with regard to maintain combat readiness. Therefore, with an eye to accomplishing designated missions, the ROC Armed Forces will pursue the tried-and-true logic to conduct force restructuring project, and 5-year policy-implementation plan so as to properly manage the needs and allocation of various national defense resources. As for setting up a sound and solid prediction model to forecast mid- and long-term national defense financial sustainability, the MND will adopt the estimated amount of mid-term annual expenses determined by the Executive Yuan as the basis for calculating the model. On the principle of “planning before acquiring

budget," sustaining national defense budget growing by 5% and military investment budget growing by 15% are set as spending caps to fulfill the needs to maintain combat readiness of the ROC Armed Forces. After acquiring national defense budget for the targeted fiscal year, such budget will be appropriated according to the order of priority.

2. Acquiring sufficient amount of national defense budget

Due to different settings on threats, strategic concepts, economic capacities and national defense policies, countries around the globe adopt different policies on the appropriation of budget for national defense purposes. Facing a highly hostile threat, achieving a posture of "effective deterrence, and resolute defense" has been the focal point of the national defense policy-implementation of the ROC. In addition, the MND will spare no efforts to improve its force structure, phase out obsolete equipment and better combat readiness rate so as to establish a "compact but delicate, highly capable, " and modernized military force to defend our nation.

Over the past several years, the national defense budget of the ROC has been continuously dwindling. Furthermore, positive adjustment of salaries and welfare for servicemen has yielded skyrocketing personnel expenses to digest our national defense budget. Besides, next-generation weapon platforms have been commissioned into current force inventory in stages, upkeep costs of these platforms have far more expensive than that of conventional weapons, and the course of the force restructuring has been thus greatly affected. In contrast, the national defense budget for the PRC has grown by 283.83% in the last decade and increased annually in two-digit percent since 1995. The MND earnestly hopes that while the government strives to achieve the steady expansion of national economy, it may keep the national defense budget on a reasonable level to achieve the goals of maintaining combat readiness and ensuring national security.

National Defense Material

I. National Defense Technology Industries

1. Objectives

In concert with the efforts to maintain combat readiness of the ROC Armed Forces, the MND shall pursue R&D activities for producing new weapon systems to assist in combat operations. As a result, the MND will expand its capacity to integrate, and apply technologies so as to establish autonomous national defense technology industries and R&D systems. It's expected that following the lead of national defense technologies domestic industries and our national competitiveness can thus be upgraded and improved.

2. Policies

It's the policy of the MND to expand cooperative spectrum across industrial, public, academia and research sectors with an aim to transfer national defense technologies into domestic industries. In addition, the MND will continuously develop weapon systems with key technologies so as to achieve autonomous national defense strength. Besides, abiding by the international treaties and government policies, the ROC Armed Forces will never produce, develop, procure, stockpile and deploy nuclear, chemical, and biological weapons.

3. Policy-implementation and Results

(1) Current development of defense technology industry

Being frontline national defense industries, the Army, the Navy, the Air Force, the Combined Logistics Forces and the CSIST plan to build up their capacities in production, maintenance and R&D of military materials in their respective professional logistics factories through acquiring

annual national defense budget, enhancing training for military personnel and establishing related mechanism (including industrial cooperation measures). The respective capacity of each service is described in following sections.

a. Army

(a) The Ordinance Readiness and Development Center has the capacity for R&D, production and maintenance for the CM21 series armored vehicle, and M48H & M41 MBT series. The Army Missile Services Division has the capacity to provide depot-level maintenance for the Hawk and Patriot missiles.

(b) Fourteen private satellite factories are contracted to produce military supplies, including left and right torque rod of CM21, control arm assembly, compartment, transmission gear, active wheel blade of M48H, support roller assembly, pod, etc.

b. Navy

(a) Each logistics command center has the capacity to provide depot maintenance for the new generation battleships and other types of military vessels. The Marine Corps factory has the capacity to provide depot maintenance for LVT landing vessel.

(b) In accordance with government initiative to develop the shipbuilding industry, effectively integrate national resources and enforce the government policy of "domestically production of naval vessels," the MND and MOEA have jointly signed the Agreement of Cooperation and Support of Shipbuilding Industry in this regard. In the scheme of mutual support, the Navy will review on outsourcing the maintenance and repair of equipment and systems or whole ships to the private sector. China Shipbuilding Corp. may serve as the leader and coordinator of the domestic shipbuilding industry to form strategic alliance and negotiate for contracts. This should save time on maintenance and repair, thus enhancing combat readiness.

(c) Twenty private satellite factories are contracted to produce military supplies, including power supply, fuel heater, rubber valves, M25C scopes, etc.

c. Air Force

(a) The First Logistic Command has the capacity to provide depot maintenance for F-5E/F, AT-3, and other types of aircraft with turbo-jet or turbo-fan engines, and has the capacity to customize various aircraft parts and accessories, repair various aircraft avionics instruments and air-to-air missiles. The Second Logistic Command has the capacity to provide depot maintenance for B-1900, FK50, C-130, S-2T, UH-1H and other types of aircraft with turbo-prop or turbo-shaft engines, and has the capacity to repair aircraft accessories for B-1900, FK50, etc. The Third Logistic Command has the capacity to engines, and the capacity to manufacture some parts and accessories.

(b) There are ten private factories contracted to produce military materials, including power connector, automatic frequency controller, power supply cable for Sentinel radar system, CIT antenna cover, circuit board, etc. Four maintenance stations are contracted to undertake repair of 1,410 items of military materials.

d. Combined Logistics Command

(a) The factories of the Combined Logistics Command have the capacity for developing and producing various conventional weapons, such as light arms, artillery, ordnance and other military materials. They also have the capacity to develop and produce thermal cells and optical equipment such as laser range finders and night vision goggles (NVG).

(b) Eighty-three private satellite factories are contracted to produce military materials, including M998 series lubricant pressure gauge, air filter, 60A generator, rod assembly, V150 front and rear steel plate assembly, etc.

e. The Chung San Institute of Science & Technology (CSIST)

(a) In order to fulfill the operational requirements of the ROC Armed Forces, the CSIST is responsible for R&D of new defense technologies, and developing and producing major weapon systems. It has accumulated immense capabilities in the fields of aviation, rockets and missiles, electronics, information and telecommunication, chemistry, material, optic-electronics, system development, information management, system maintenance, and system manufacturing. It has established a solid foundation in the system integration, testing & verification, simulation & analysis, and logistic support involved in large-scale projects. The CSIST has successfully delivered the ROC Armed Forces critical weapon systems and equipment for air and naval defense, anti-landing operations, C³I, and electronic warfare.

(b) In order to incorporate the advanced industrial technology from the private sector and to support domestic companies with solid management and sufficient capacity in defense specialty, the CSIST has contracted 20 private satellite factories to produce military materials. The contracted products include server modules, remote testing warhead, radar retainer disk, engine ignition control box, M423 fuse, etc.

(2) The status of industrial cooperation projects (including domestic industries and units of the ROC Armed Forces)

a. Currently, offset (industrial cooperation) level of our nation has reached US\$ 5.2 billion (among them, US\$ 4.1 billion are gained through important foreign arms deals by the ROC Armed Forces). Totally, US\$ 4.3 billion have benefited domestic industries and the ROC Armed Forces units. Offset items related to industrial cooperation include technological transfer, domestic procurement, domestic investment, evaluation and certification, personnel training, marketing assistance, collaborated development, etc.

b. Currently, the ROC Armed Forces has used an offset level of more

than US\$ 800 millions, and 33 offset projects are implementing with foreign companies. Among them, the two best indicative examples are “technological transfer of 40mm rocket launcher” by Combined Logistic Command, and “technological transfer of depot-level maintenance capabilities for missiles of Mirage 2000-5” by the CSIST.

(3) The orientation of defense industrial resource allocation

a. Under the policy to develop an autonomous national defense, weapon systems produced by the ROC Armed Forces are growing in proportion annually, which in turn stimulates the development of defense technology industry. As stated in Article 22 of National Defense Law, “Government agencies under the Executive Yuan shall follow national defense policies to consolidate efforts of the private sector to develop defense technology industries. Acquisition of weapon equipment shall firstly consider those built domestically. When it is necessary to pursue outsourcing channels, the acquisition activities shall realize technology transfer policy so as to establish an autonomous national defense infrastructure.” This statement has laid a solid legal foundation for the defense technology industry to take root in the private sector. In accordance with this Article, the MND has promulgated three regulations governing the signing of agreements with private organizations to cooperate or work in mutual commission in the development, production, maintenance and sales of military items. That can serve as the basis for establishing military armament system.

b. In the operation of acquiring military supplies through outsourcing channels, the MND constantly faces the dilemma involving “foreign aids.” Currently, the focus of current national defense industry research are as follows: the consideration of “professional division of labor” generating larger benefit than the “wholesale contracting model” of operation and management; using the concept of “core competency” as the

criteria for evaluating whether to adopt the “outsourcing” model in decision-making; and establishing a mechanism for the decision-making and evaluation models for the core competency of defense technology industry. Through the operation of this dynamic mechanism, we hope to find the basis for the reasonable allocation of resources for the core and non-core segments. Moreover, we hope to achieve the ultimate goal of creating the synergy of weapons and equipment through the horizontal or vertical integration in the partnership relationship of the MND and the private sector.

(4) Measures in accordance with governmental policy-implementation

a. Promoting concept of government-owned & contractor operated (GOCO) military factories

In order to establish the GOCO system, the MND has completed a preliminary research phase in this regard from 1996 to 1998, and initiated the test-run phase in 1999. In November 2001, authorized by Article 22 of the National Defense Law, the MND promulgated the draft of “Statute for Commissioned Private Operation and Management of the MND Technology and Industry Institutions.” The draft has been reviewed by an inter-ministry board meeting and approved by the Executive Yuan, and is promulgated March 1, 2001 to boost the promotion of GOCO system.

b. Establishing an autonomous national defense technology industry and R&D system

Considering the needs for national security, the productivity of domestic industries, and the trend of development of weapon systems, the MND is planning to establish a military armament organization, institute an assessment mechanism for acquisition of military materials, and create a mechanism for promoting defense technology industry development by tapping into the expertise from industry, government,

academia and research community. By implementing the policy to integrate defense technology industry with the private sector, the MND seeks to achieve the goals of “maintaining an autonomous national defense posture, establishing an all-out defense mechanism, developing a technology-based military force, and purchasing domestically made weapons and equipment first.”

c. Promoting technological innovative strategies

The MND aims to expand long-term innovative research, assist the upgrade of traditional industries, and focus on integrated interdisciplinary projects to increase their added values. By taking such measures as running an incubation center in the Park of the CSIST Park and assist the Park administration in opening its laboratories, the MND hopes to encourage the participation of domestic contractors in developing innovative defense technologies. Furthermore, the results of scientific research projects should be effectively managed with the concepts of marketing and protection of intellectual property. This can improve the quality and efficiency of R&D and enhance the competitiveness of domestic industries.

d. Promoting the operation of commercial maintenance for military aircraft

Commercial maintenance for military aircraft is a policy that has the benefits of introducing new techniques from abroad, saving the time for shipping the aircrafts to the original manufacturer for maintenance work. It is therefore essential for elevating the readiness rate of military aircrafts and enhancing the quality of aviation and space technology research in Taiwan. After weighing considerations such as the domestic capacity for aviation and space industries, the return on investment, and willingness to perform contracts and government regulations on procurement, the MND has completed the planning of “strategic commercial maintenance of military aircraft.” The concept in-

cludes study and analysis of concrete measures such as the depth of releasing maintenance contracts to commercial contractors, the method of release, stages of planning, and the schedule for implementing. Conferences are held on various levels to build wide consensus on this matter, so that all services of the ROC Armed Forces are familiar with the guidelines for the MND policy of commercial maintenance for military aircraft, and the ensuing measures to implement the policy.

e. Publicizing the list of national defense military supplies procurement:

In response to the changes brought about by the ROC's participation in the WTO Government Procurement Agreement (GPA), the government needs to provide a list of product open for free trade in its bilateral negotiations with major member economies. As for the category of defense military supply procurement, the MND has certified 107 classes of products open for free trade. The free and open procurement of defense military supplies will still be guided by the highest principle of protecting the overall interests of the country. On condition that it does not affect the autonomy of national defense and the development of national economy, the MND will join with related authorities to review the measures and achieve the policy goals of joining the WTO.

(5) Measures for promoting developing national defense technology industries

a. Promulgation of defense technology industry development regulations

Promulgated in Article 22 of National Defense Law are many fundamental policies, such as "collaborative development of defense technology industry with the participation of the private sector," "domestically made weapons and equipment have priority in acquisition," "procurement deals with foreign companies should include terms for tech-

nological transfer to cultivate capabilities of domestic production,” and “use a variety of methods such as cooperation, mutual commissioning, or commissioned operation in combining the strength of private enterprises.” In accordance with these policies, the MND has promulgated three subordinate laws for implementation: “Regulations for Joint Research, Development, Production and Maintenance by the MND Technological Industry Institutions and Legal Persons,” “Regulations for Merchandising Products of the MND Technological Industry Institutions,” and “Regulations for Private Operation and Management Commissioned by the MND Technological Industry Institutes.” In the future, the development of defense technology industry will go in the direction of combining the strengths of private enterprises; by engaging in cooperation or mutual commissioning with domestic and foreign legal persons in research, development, production and maintenance, the ministry may steadily approach the goal of national defense autonomy.

b. Promoting the sharing of technology among civilians and the military

The opening of the CSIST science research parks in Ching-shan, Lung-yuan and Taichung provides venues for the MND to provide government agencies and private companies with technological services. In the future, the Ministry shall conduct more surveys on the needs of the industrial markets to help industries take advantage of business opportunities and make greater contribution to the national economy.

c. Striving for offset (industrial cooperation) level with foreign contractors

Over the years, the offset deals attached to foreign weapon procurements have provided considerable benefits for the technological upgrade of domestic industries and the improvement of overall logistic capacity for the weapon systems of the ROC Armed Forces. In order to take further advantage of this situation, the MND has modified related paragraphs in “Regulations of Industrial Cooperation” to make it man-

datory for foreign weapon purchase deals worth US\$ 10 million or more to require the contractor to offset deals worth 30% or more of the total price. Furthermore, the MND has stipulated three implementation guidelines for effective technological transfer, these guidelines are as follows:

- (a) Using the “collaborative production” model to absorb related know-how and management knowledge
- (b) Using the “joint research and development” approach to obtain design and technology of system integration technology.
- (c) Striving for enhanced research and development capacity and seeking the exchange of critical technology.

d. Promoting cooperation between the military and the academia

Through the academic cooperation coordination team under “Defense Technology Development and Promotion Committee,” the MND continues to entrust several universities to conduct studies in five categories- aviation, missiles, electronics, chemistry, and materials. Also, the MND uses the research budgets provided by Defense Industry Development Fund to employ public and private education and academic institutes to conduct advanced defense technology research. Research teams may be established to plan for prospective weapon systems or development for the production technology of parts and components. The result of their research will be provided to defense technology research and development units and related industries.

II. Acquisition of Weapons

1. Research and development

The CSIST of the MND is responsible for the research and development of defense technology, as well as the design and production of major weapon systems. Currently it has research units in aviation, rockets and

missiles, electronics, information, chemistry and chemical engineering, materials, and optoelectronics. With capacity of weapon systems production and integration, the CSIST is one of the most important resources of military industrial R&D and technology. The following is the general description of its research capacities:

a. Aviation

The CSIST is able to design and analyze aviation engines, as well as to conduct their simulation, assembling activities, ground tests and flight tests. According to the needs of the Air Force in military buildup, weapon acquisition and combat preparedness, the CSIST may also make integration of aerodynamics, flight control, and weapon system interfaces. Furthermore, it can execute analysis and evaluation of battle efficiency to provide important insight for the Air Force decision-making process in the acquisition of weapon systems.

b. Missiles and rockets

The CSIST is able to design, develop, assemble various types of missiles, as well as conduct flight tests, verification and evaluation on them. The CSIST has Taiwan's only general testing range for missiles and rockets that can be used by the ROC Armed Forces for testing weapons developed in-house or procured from abroad, and may provide necessary support to the development of the country's most advanced aviation and space technology.

c. Electronics and information technology

The CSIST is able to develop radar and fire control systems, electronic warfare equipment, military communication, secrecy equipment, electronic components and parts, optic-electronic equipment, software engineering, underwater detector and underwater weapons.

d. Chemistry and chemical engineering

The CSIST has the capacity in technological development and production in various types of solid propellant, high-capacity dynamite,

warhaed, anti-corrosion and waterproof technology, chemical warfare protection equipment, and chemical analysis and examination.

e. Materials and optic-electronics

The CSIST has the capacity to conduct testing, analysis, processing, development and production in high-temperature materials, composite materials, electric conductive materials, solid-state and optoelectronic component materials, optoelectronic and infrared technology, laser technology, alloy technology, etc.

2. Manufacturing

With experiences accumulated from commissioning the mass production of various types of missiles, the CSIST has established comprehensive capacity in missile and rocket manufacturing technology, which includes the fields of "machinery design and manufacturing," "quality assurance and testing," "missile assembly and testing," "firearms design and manufacturing" and "computer integrated management information system." It can sufficiently support the test production of research projects, the deployment of follow-up mass production, and logistic and maintenance work.

3. Production

In this stage, a schedule is made according to national financial resources and defense needs. The focus is on assuring quality and lowering costs. After a considerable amount is produced, the weapon systems are transferred for use in the ROC Armed Forces, and thus the deployment stage begins. In other words, the stages of production and deployment have long overlap. To avoid the irrecoverable situation, in which flaws of weapon systems are discovered only after deployment, lead production is arranged before mass production. A small number of weapon systems are produced for the ROC Armed Forces to try out in real combat situations in order to discover and correct problems as early as possible.

4. Procurement

(1) Policies

In accordance with the government policies of free trade and globalization, and under the supervision of the public, the MND strives to establish a legal, transparent, fair and reasonable environment for procurement operations. It should accomplish its mission of procuring military supplies for the ROC Armed Forces with combat and national security considerations, utilizing limited resources to satisfy the requirement of military buildup. The following principles should be followed:

- a. Procurement of domestic products first: military supplies or services that can be produced or provided domestically or those that may or may not be produced and provided domestically should be purchased locally. Only in the case that the products or services are certain to be unavailable from domestic suppliers or cannot meet the needs of the ROC Armed Forces, procurement may be made abroad.
- b. Diversification of sources of procurement: considering the changes in international situations, the sources of weapon acquisition should be widened through various channels and diversification of locations for procurement, and thus to be less dependant on any single nation (or region).

(2) Implementation

- a. Implementation of annual procurement projects: in FY 2001, the ROC Armed Forces have executed a total of 13,461 procurement cases worth NT\$ 99,564,490,000. Among them, there are 13,042 domestic procurement cases, 371 foreign procurement cases and 48 cases of arms sales. In terms of bidding processes, 12,028 cases were executed through public bidding, 153 cases through selective bidding and 1,280 cases through restrictive bidding. (Figure 3-15)
- b. Collection of international market information: the MND plans to visit major military supplies and weapon manufacturers in America and

Figure 3-15 The Procurement Projects in FY2001

Category	Procurement	Domestic Purchasing	Foreign Purchasing	Military Sale
		Statistic of cases	No. of cases	15,433
	Percentage	93.95%	5.69%	0.35%
	Total cases	16,426 cases		
Statistic of amount (Unit: NT\$ 10,000)	Sum	2,465,909	2,480,016	2,742,651
	Percentage	32.07%	32.26%	35.67%
	Sum total	7,688,576		

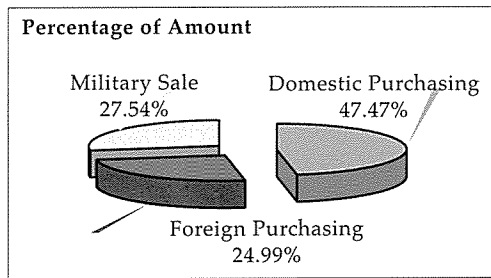
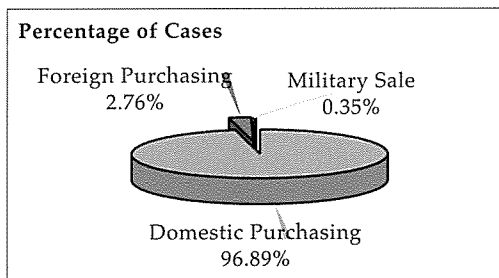

Category	Call for Bids	Open Tendering Procedures	Selective Tendering Procedures	Limited Tendering Procedures
		Statistic of Cases	No. of Cases	6,699
	Percentage	40.78%	38.45%	20.77%
	Total Cases	13,461 Cases		
Statistic of Amount (Unit: NT\$ 10,000)	Sum	1,864,503	631,876	5,192,197
	Percentage	24.25%	8.22%	67.53%
	Sum Total	9,956,449		

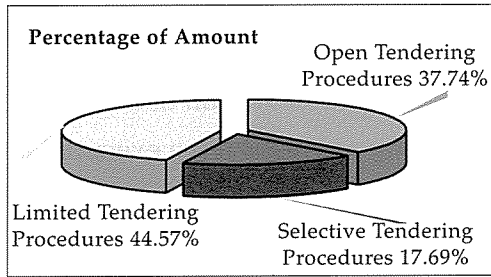
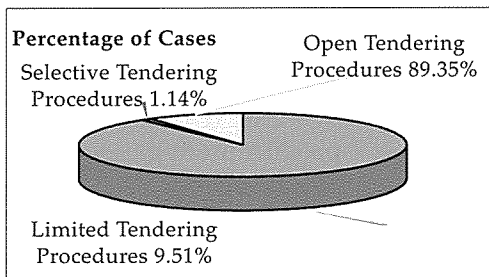

Europe, gathering the latest market information for use by the ROC Armed Forces and entry into the market information database.

c. Organizing vendor conferences: the MND organized vendor confer-

ences to provide better services for the companies and exchange of opinions.

d. Improvement the efficiency of procurement process: the MND effectively takes advantage of the functions granted by the Government Procurement Law by using new procurement methods. For commonly needed items or items that require long-term supply but without regular recurrence or predictable amount, it adopts “joint supply contracts” and “open contracts” when appropriate. This will lead to smaller number of procurement cases and save on time and human resources.

e. Enforcement of three-stage operation: the MND requires the procurement units on all levels of the Armed Forces to strictly follow the three-stage model of independent operation: planning and application, bidding and contracting, and contract operation, verification and closure. This model can provide check and balance, avoiding corruption.

f. Computerization of procurement information: in keeping with the global trend of information and electronic technology, the MND has developed and deployed an Automatic Project Reporting System and Schedule Control and Record Making System to effectively enhance the quality of project report writing and efficiency of operation. Also, it employs measures promulgated by other competent authorities such as Electronic Company Catalogue, Electronic Quoting System, and Electronic Bidding System; this can make the procurement procedure more open and transparent, and lower the cost of procurement operations.

(3) Concrete measures in accordance with the implementation of Government Procurement Law

a. Amend outdated laws and regulations to improve the procurement operations of the ROC Armed Forces:

According to the regulations in Article 104 of Government Procurement Law, the MND has promulgated Regulations for the Range of Application and Treatment Methods for Special Military Procurement. This

statute will serve as the guideline for emergency or classified procurement of weapons and ammunition.

b. Continual education and training to enhance the quality of personnel:

(a) The MND organized "entry-level" and "intermediate-level" procurement specialty training courses for related procurement personnel from all levels of the ROC Armed Forces.

(b) The ROC Armed Forces attend the "Procurement Law Training Program" organized by Public Construction Commission of Executive Yuan.

(c) Provide supervision and guidance to low-level units in the ROC Armed Forces on small-value procurement cases (worth under NT\$ 1 million) to effectively correct the problems in the operations and improve the efficiency of the procurement procedures.

III. Land for National Defense Usage

1. Objectives and Policies

In order to meet the demands of national economic development, comply with national land development policies, and maximize the utility of land, the MND has made a comprehensive review of land for military use on the premise that military buildup and combat readiness are not compromised. According to the policies that "small barrack compounds be combined to large compounds" and that "barracks and training sites not required to be located in urban areas be moved to suburban or mountain areas," the MND made timely review to release the unused or unsuitable land for barrack compounds.

2. The classification of land for military use and principles for treatment

a. Areas Prioritized for Military Use

Given no alternative sites, military facilities in these areas were established for military needs. Therefore, these areas cannot be demilita-

rized before their functions are replaced or repealed. These sites should be designated as restricted development zones prioritized for military use, such as airports, harbors and missile bases.

b. Areas for General Military Use

Economic development and social changes around military-use areas have caused a squeezing effect, which has reduced the military value of these lands. Facilities on these lands, indispensable for military readiness though not directly to be involved in military operations, can be conditionally relocated to suburban or mountainous areas in line with urban development plans. Examples of such facilities are: logistic plants and warehouses, office buildings, academies and schools, or small training fields.

c. Areas not for Direct Military Use

These generally refer to land for military residential compounds or open space without plans of utilization. Having no relevance to military deployment, these areas shall be transformed into non-public property and transferred to be sold under the jurisdiction of National Property Bureau. The payment from the land may then be used according to local development.

IV. Vision

1. The ROC Armed Forces will continue coordinate resources from private sectors to develop national defense technology industry. The goals are to create the comprehensive benefits of effectively combining defense resources and national resources, adjust the allocation of resources in the defense technology industry, and to build autonomous capacity of research and development, production or maintenance that is rooted in the private sectors.
2. Guidelines for the ROC Armed Forces weapons and equipment procurement will be mainly with domestic acquisition and partly with foreign procurement. Military items procurement will be headed to the directions

of internationalization, effectiveness, and informationalization. The purpose is to build a clean procurement system without scandals. Procurement personnel can be suitably placed and the goal of professionalization can be achieved.

3. The MND considers the upcoming “streamlining program,” weapon and equipment renewal, and the deployment and adjustment of manpower and firepower, on condition that military facilities and security are not compromised. Considering the national economic construction, local and urban development, and the rights entitled to the citizens, the MND tries to achieve balance in important national construction projects and the demand of national combat readiness to maximize land utility.

PART FOUR
ROC ARMED FORCES

Summary

1. In peacetime, the ROC Army emphasizes on defending critical posts of strategic significance on Taiwan Proper and offshore areas; ensuring crucial bases, factories, and depots; and conducting basic training for maintaining capabilities in responding to contingency. In wartime, it conducts joint warfare with the Navy and the Air Force, annihilating invading enemies.
2. The ROC Navy conducts naval reconnaissance and patrolling, supply of offshore islands and escort of ships in peacetime while countering sea blockades and conducting naval interception as well as joint warfare with the Army and the Air Force in wartime. The ROC Marine Corps is to defend naval bases and appointed offshore islands in peacetime, while engaging in combat mission in wartime.
3. In peacetime, the ROC Air Force emphasizes military preparedness and ensures the airspace, while seizing air supremacy and conducting joint warfare with the Army and the Navy in wartime.
4. The ROC Military Police is to conduct special guard and garrison missions; assist the police in maintaining public security; support military operations; and carry out tasks pursuant to martial law and judicial laws.
5. Electronic Warfare Forces, premising on "building an electromagnetic shelter over the Taiwan Strait and obtaining electromagnetic superiority", will effectively utilize electronic support and protection means to create electronic superiority so as to achieve overall missions. The primary missions of Information Warfare Forces are to safeguard and monitor command & control systems; seize information superiority; and assist in overall combat missions in time.
6. The Reserves, pursuant to the principle of "the integrated management, organization, allocation, training and employment," puts emphases on mobilizing reserves units faultlessly; reorganizing reserves rapidly; and recommencing reserves' combat capability quickly. In peacetime, the

Reserves emphasizes on fostering low-level cadres; and implements the reserves' mobilization preparedness of the comprised personnel, allocation and training, while timely expanding into combat forces capable of conducting combat missions at the eve of war.

7. In peacetime, the Reserve Command implements military preparedness and keeps relevant personnel and resources in control, ensuring to maintain constant combat-ready. In wartime, the Reserve Command is to conduct ongoing mobilization and assist in military operations, combat damage prevention and diaster relief work while maintaining security of the rear areas by employing the capabilities of the reserves and civil defense units.
8. The Combined Logistics Command is responsible for researching, developing and manufacturing traditional weapons systems and provides common services supporting for the ROC Armed Forces and support combat-related missions with minimum resources. Support military services units subordinate to the Reserve Command, grouped into the ones attached to County/City Reserve Command and the ones attached to the regular forces, will effectively integrate civil resources purposing to participate in disaster relief work in peacetime and assist in military services in wartime.

Chapter 1

Regular Forces

I. Army

1. Missions

The ROC Army is established to defend state's territory and to ensure the integrity of sovereignty. In peacetime its mission is centered on defending critical posts of strategic significance on both Taiwan Island and offshore areas, and conducting basic training for maintaining capabilities in responding to contingency. The Army also assists to secure crucial bases, facilities and depots as well as renders regional disaster relief works if demanded, while conducting joint operations with the Navy and the Air Force to defeat invading enemies in wartime.



ROCArmy Airborne Cavalry unit conducts training.

2. Present Situation

(1) Strength

Approximately 190,000 people.

(2) Organization

The Army GHQs has under it Army Corps, Defense Command, Aviation and Special Warfare Command, Army Logistics Command, Air-defense Missile Command, Division Commands, Armored Brigades, Armored Infantry Brigades, Motorized Rifle Brigades, Infantry Brigades, Airborne Cavalry Brigades, Special Warfare Brigades, and Testing & Measuring Center.

(3) Main Weapons and Equipment:

AH-1W attack helicopters, OH-58D scout helicopters, M-48H MBTs M-60A3 MBTs, man portable air defense missiles, vehicle-mounted air defense missiles, M-109A5 self-propelled howitzers, Sky Bow air defense missiles, and Patriot air defense systems.

II. Navy

1. Missions

The mission of the ROC Navy is focused on ensuring the Taiwan Strait and maintaining the safe passage of SLOCs. The Navy conducts naval reconnaissance and patrolling, supply of offshore islands and escort of ships in peacetime while countering sea blockades and conducting naval interception as well as joint operations with the Army and the Air Force so as to ensure the capabilities in sea control in wartime. The ROC Marine Corps is to defend Navy bases and appointed offshore islands in peacetime while engaging in combat mission in wartime.

2. Present Situation

(1) Strength

Approximately 50,000 people.

(2) Organization

The Navy GHQs has under it Naval Fleet Command, Chinese Marine Corps Command, the Education, Training & Doctrine Development Command, Navy Logistics Command, Destroyer Fleet, Frigate Fleet, Submarine Fleet, Mine Fleet, Service Fleet, Amphibious Fleet, Fast Attack Boat Force (missile), Naval Aviation Force, Land-based Missile Force, Surveillance and Communication System Command, Base Command, Marine Corps Brigade, Oceanic Survey Bureau and Oceanic Development Center.

(3) Main Weapons and Equipment:

Missile frigates, missile destroyers, missile corvettes, missile fast attack craft, mine sweeping (laying) vessels, submarines, fixed-wing ASW aircraft, ASW helicopters, amphibious ships, landing vehicles, etc.

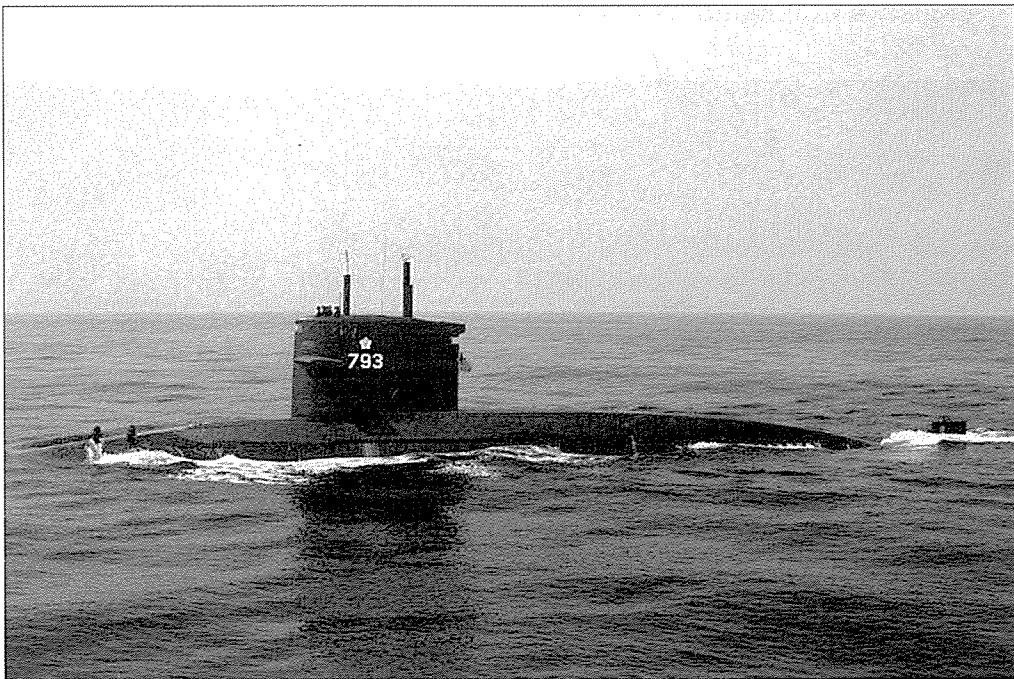

ROC Navy submarine patrols territorial waters.

III. Air Force

1. Missions

The ROC Air Force is established to defend the air space, join hands with the Army and the Navy to secure both territory and territorial waters integrity, and maintain our national sovereignty. In peacetime, it emphasizes on military preparedness and ensures the airspace, while seizing air supremacy and conducting joint operations with the Army and the Navy in wartime.

2. Present Situation

(1) Strength

Approximately 50,000 people.

(2) Organization

The Air Force GHQs has under it Air Combat Command, Air Force Logistics Command, Air Defense and Garrison Command, Education,



Formation training of ROC Air Force's Mirage 2000-5 fighters.

Training & Doctrine Developing Command, Base Command, Tactical Fighter Wing, Combined Wing, Air Tactical Control Wing, Communications & ATC Wing, Weather Wing.

(3) Main weapons and Equipment

IDFs, F-16s, Mirage 2000-5 fighters, the Sky Sword II missiles, etc.

IV. Military Police

1. Missions

The ROC Military Police is to conduct special guard and garrison missions; assist the police in maintaining public security; support military operations; carry out tasks pursuant to martial law and judicial laws to ensure national security and social stability.

2. Present Situation

(1) Strength

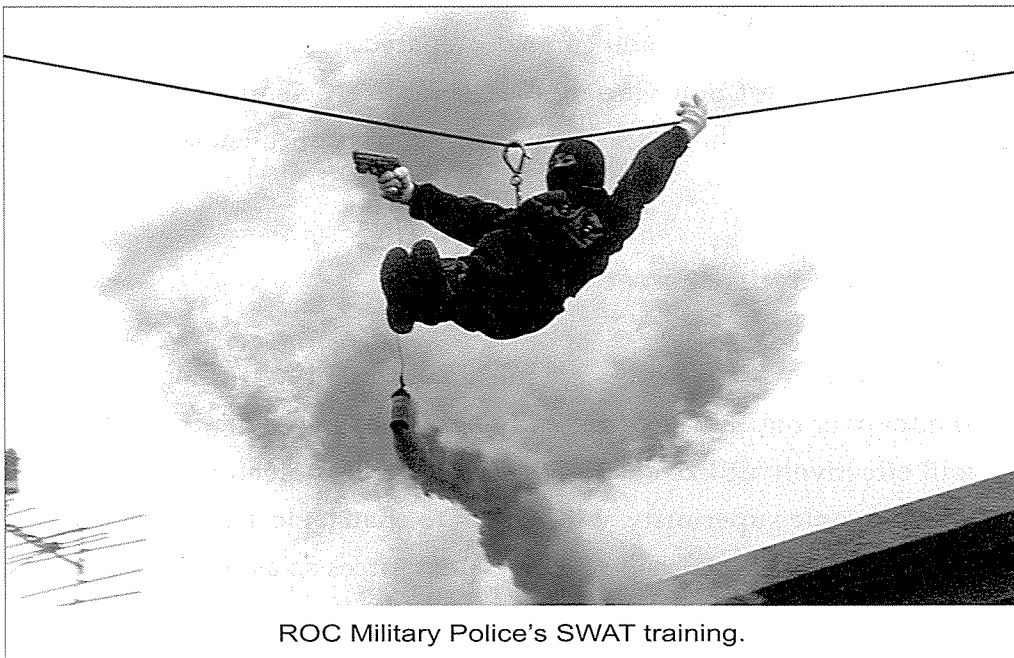

Approximately 10,000 people.

(2) Organization

The Military Police Command has under it Military Police Area Command, Investigation Unit, Maneuver Unit, Military Police Battalion and Basic Military Training Center.

V. Electronic and Information Warfare Forces

With advancing in sci-technology and changing in war patterns, to snatch “information and electromagnetic supremacy” becomes the top prioritized target for the belligerent parts of wars. Combined knowledge from professional information-electronic warfare and force deployment is deemed the key to multiply combat efficiency. The MND is actively fostering indigenous defense capability while integrating the efforts of industrial sector, government, academia, R&D sector purposing to enhance the capabilities of the information and electronic forces, thus to pertain information-electronic warfare advantage. The MND, in line with enemy’s movement, conducts education, training and combat preparedness; and simulates means of information-electronic warfare protection to efficiently enhance overall combat capability of the ROC Armed Forces and ensure all missions achieved as well.

1. Electronic Warfare Forces

(1). Missions

Electronic Warfare Forces, premising on “building an electromagnetic shelter over the Taiwan Strait and seizing electromagnetic superiority,” will effectively utilize electronic support and protection means to create electronic superiority, with which to snatch electromagnetic dominating features and deploy main combat forces so as to achieve overall missions.

(2) Organization

- a. **Army:** Under its command are electronic warfare battalions responsible for conducting electronic warfare in joint ground defense operations, aiming to assist in missions of defense operations efficiently.
- b. **Navy:** Under its command are electronic squadrons responsible for conducting electronic warfare in joint sea-denial operations, aiming to assist in missions of defense operations efficiently.
- c. **Air Force:** Under its command are electronic warfare groups responsible for conducting electronic warfare in joint air-domination operations and joint counter-warfare, aiming to assist in missions of defense operations efficiently.
- d. **Chung Shan Institute of Science and Technology (CSIST):** The Institute is responsible for the R&D, manufacturing, testing and evaluation of the electronic warfare weapons.

2. Information Warfare Forces

(1) Missions

The primary missions of Information Warfare Forces are to safeguard and monitor C² systems, to obtain information superiority in time and to support overall combat missions.

(2) Organization

- a. Communication & Information Command is responsible for monitoring information security protection means and developing the capacity of counter-warfare.
- b. GHQs of each service is responsible for protecting information security by its nature, monitoring systems under its control and developing information warfare tactics and techniques.
- c. The CSIST is tasked to maintain network security and develop anti-cyber attack capability.

VI. Vision

The MND is focusing its attention on establishing a “professional elite, powerful and sophisticated” armed force capable of creating relative strategic superiority and thus achieving the mission of “Effective Deterrence and Resolute Defense”, with most of its attentions focused on as follows:

1. Seizing Information Superiority and Early Warning Capability

The ROC Armed Forces will take the initiative through conducting information & electronic operations; dominate the theater with omni-directional integrated systems; conduct on-going deployment and implement the preplanned deployment in line with threat assessment, resources acquired and military preparedness. The said efforts will create information superiority; satisfy the acquirement of defense information; strengthen capabilities in early warning and C²; elaborate the effectiveness of the integrated communications and information; carry out both offensive and de-



Seizing information superiority and early warning capability

fensive capabilities in information and electronics warfare; and demonstrate modeling & simulation.

2. Envisioning Intelligence, Dominating the Theater

The ROC Armed Forces will maintain early warning capability with multi-intelligence collection means; and envision enemy intelligence with professional intelligence research. It will dominate the theater through the following efforts to obtain enemy's correct and timely movement:

- (1) to enlighten enemy movement through three-dimensional reconnaissance and surveillance in an effort to obtain perspective intelligence;
- (2) to provide early warning by means of long-term monitoring and systematic analysis efforts;
- (3) to share information through information superiority and rapid analysis;

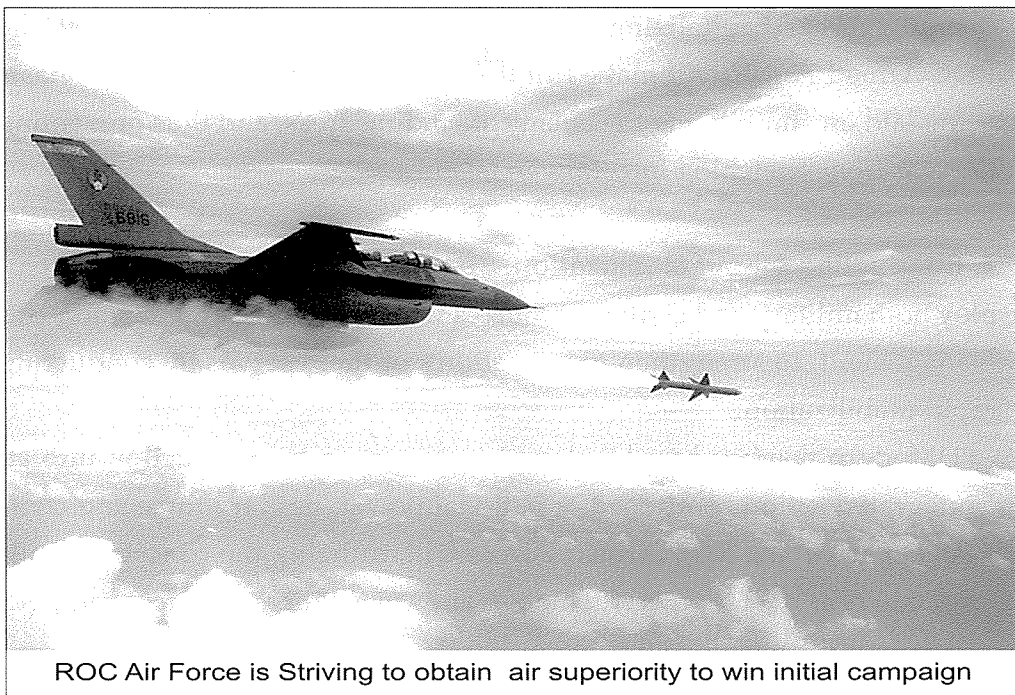

(4) to integrate resources by introducing talented personnel and well-structured organization.

3. Defeating the Enemy with Air and Naval capabilities, Annihilating the Enemy at Landing Areas

The ROC Armed Forces seizes the initiative with superior counter-capabilities; annihilates enemies by conducting joint operations; maintains air and sea superiority; and strengthens counter-capabilities so as to deter the enemy from staging abrupt military operations. If a war is unavoidable, the ROC Armed Forces will on one hand, guided by “conducting a defensive operation decisively,” snatch the first campaign by means of thriving to obtain naval and air superiority, and on the other hand, race against the time based upon the guidance of strategic vitality. If a war still could not be restrained, the enemy stages an overwhelming attack against Taiwan. Guided by “conducting air domination, sea control and ground defense operations” and capitalizing on a natural obstacle—the Taiwan Strait, the ROC Armed Forces will make full use of joint operations with emphasis being laid on annihilating the enemy at landing areas, and thus preventing the war from stretching into Taiwan Island.

4. Conducting All-out Mobilization, Strengthening the Reserves: to employ both military and civilian resources with systematic organization and management, to strengthen the capability of the reserves by conducting rapid mobilization.

(1) Modern warfare has developed from a pure military action into an integrated action comprised of national power, military force and civilian capacity. the ROC Armed Forces will, utilizing the concept of “all-out defense,” foster powerful mobilization capability of the reserves with the support from all countrymen.

(2) Being short of early warning time, lack of in-depth area and determin-

ing a battle rapidly and decisively are the characteristics of Taiwan-Penghu defensive operation. Therefore, the MND should, in line with future warfare patterns, set up the system of “conducting immediate mobilization and immediate combat.”

5. Integrating resources, Unifying Logistics

The ROC Armed Forces will adopt privatized management patterns to improve capacity; achieve effectiveness through efficient organization. In order to render sufficient support for Taiwan-Penghu joint defensive operation, the ROC Armed Forces will restructure logistics units; and implement overall combined logistics effective to both peacetime and wartime.

6. Refining Organization, Effectiveness being Imperative

The ROC Armed Forces will strengthen its capability with appropriate force structure; improve effectiveness with a flexible chain of organization; exploit and allocate the limited defense resources with effective and reasonable means. The ROC Armed Forces will establish a new generation of rapid reaction force through envisioned and overall planning and efforts of military preparedness; and thus set up a agile, learning, growing and efficient military organization by means of restructuring.

7. Improving Education, Recruiting Talented Personnel

The ROC Armed Forces will foster qualified cadres by offering professional education; carry out the policy of employing the talented based on his specialty through specialty-oriented promotion channel. In order to meet with the military threats and challenges in the 21st century, the ROC Armed Forces must restructure military organization; set up an elite, small and powerful force; establish a learning, growing and reflective military organization capable of being responsive to changes and challenges. However, the key to achieve the said efforts is to improve personnel

continuously. Thus, the ROC Armed Forces should, on one hand, recruit excellent youth from the society and develop them into qualified cadres with professional military education; and on the other, employ and promote talented military cadres based on his specialty by means of the specialty-oriented promotion channel.

Reserves

Pursuant to policy guidelines for “reducing regular forces and expanding reserves,” the regular forces are being downsized continually. Therefore, the reserve forces must be reinforced to sustain normal combat capability of the ROC Armed Forces. In order to ensure the reserves’ reliability, the MND, in line with the guideline of “the advanced technology taking the lead, regular forces conducting strikes, and the reserves defending the rear,” has streamlined the reserves’ organizations, training and hardware equipment so as to timely support in military operations.

I. Army Reserves

1. Missions

In peacetime, the Army reserves are to conduct education training, combat training tests, service support, and mobilization readiness in accordance with the nature of their overseeing unit. In wartime, these forces should mobilize rapidly to defend both the rear areas of the first-line and the in-depth areas or support services.

2. Organization

In peacetime, schools, factories and testing centers function as overseeing units, while they expand into infantry reserve brigades, combat groups, commands and regiments of each branch of armed forces in wartime.

II. Navy Reserves

1. Missions

In peacetime, the Navy reserves are to conduct education training, service support, and mobilization readiness in accordance with the nature of their overseeing unit. In wartime, the forces should be mobilized to de-

fense in-depth areas and bases, or to assume coastal supporting duties.

2. Organization

(1)Coastal Vessel Units: The units involved are maritime services groups, rescue groups, mine-laying & -sweeping groups and personnel replenishment groups;

(2)Marine Corps: In peacetime, schools and basic military training centers function as overseeing units, while in wartime they will expand into marine reserves brigades and reserves battalions.

III. Air Force Reserves

1. Missions

In peacetime, the Air Force reserves are engaged in safeguarding bases and conducting mobilization preparedness in accordance with the nature of their overseeing unit, while in wartime they should mobilize to assume the duties of defending bases (sites).

2. Organization

Base safeguard battalions function as overseeing units, while in wartime they will expand into reserves safeguard battalions.

IV. Reserve Units of the Combined Logistics Command

1. Missions

In peacetime, the reserves units of the Combined Logistics Command are responsible for base maintenance & repair services and mobilization preparedness in accordance with the nature of the overseeing unit, while they should mobilize to assume the duties for safeguarding factories and garrisoning local areas in time of war.

2. Organization

Bases, factories and basic military training centers serve as overseeing

units, while they will expand into reserves safeguard battalions, vehicles transport battalions and port services battalions in time of war.

V. Reserve Units of the Reserve Command

1. Missions

In peacetime, the reserve units of the Reserve Command are engaged in education, training and mobilization preparedness in accordance with the nature of the overseeing unit, while they should mobilize to safeguard in-depth areas, mountain areas and posts; ensure significant economy infrastructure; and provide military services supports in wartime.

2. Organization

The personnel, selected from cadres of regular forces or reserves, are organized into reserve brigades, reserve mountainous companies, reserve regiments and reserve battalions subordinate to each Reserve Division Command and County/City Reserve Command in peacetime. They will be expanded and included into the command and control of the combat system in wartime.

VI. Reserve Units of the Military Police Command

1. Missions

In peacetime, the reserve units of the Military Police are engaged in education, training and mobilization preparedness in accordance with the nature of the overseeing unit. In wartime, the forces should mobilize to defend pivotal areas and safeguard the township with in-depth areas.

2. Organization

Schools and basic military training centers function as overseeing units, while they will expand into reserve commands, battalions and companies in wartime.

VII. Vision

The Reserves, pursuant to the principle of “the integrated management, organization, allocation, training and employment of reserve units,” puts emphases on mobilizing reserves units faultlessly; reorganizing reserves rapidly; and recommencing reserves’ combat capability quickly. In peacetime, the MND emphasizes on fostering low-level cadres and implements the reserves’ mobilization preparedness of the comprised personnel, allocation and training while expanding into combat forces capable of conducting combat missions at the eve of war.

Logistic Support Forces

I. Combined Logistics Command

1. Missions

The Combined Logistics Command is responsible for researching, developing and manufacturing traditional weapons, ammunition, quartermastering, communications & optic equipment, and mapping for the ROC Armed Forces. It also executes common services supporting for the ROC Armed Forces, including supply of common equipment, maintenance, repair, transportation, surveying, construction engineering, rear echelon administration service, and the conveyance of foreign resources. It utilizes information technology and modern management means to simplify operational procedure and streamline organization structure purposing to support combat-related missions with minimum resources (manpower, expenditure and materials).

2. Current Status

(1)Strength

Approximately 10,000 people

(2)Organization

Under the Combined Logistics Command are arsenal factories; production of quartermaster service factories; mapping factories; optics factories; printing factories; map storehouses; district transportation centers; transportation commands; fuel supply commands; parachute kit assembly factories; ammunition storage warehouses; quartermaster service base divisions; vehicle base service divisions; chemicals base service divisions; weapon material base service centers; communication device base service divisions; general equipment storehouses; and local real estate construction & real echelon administration units.

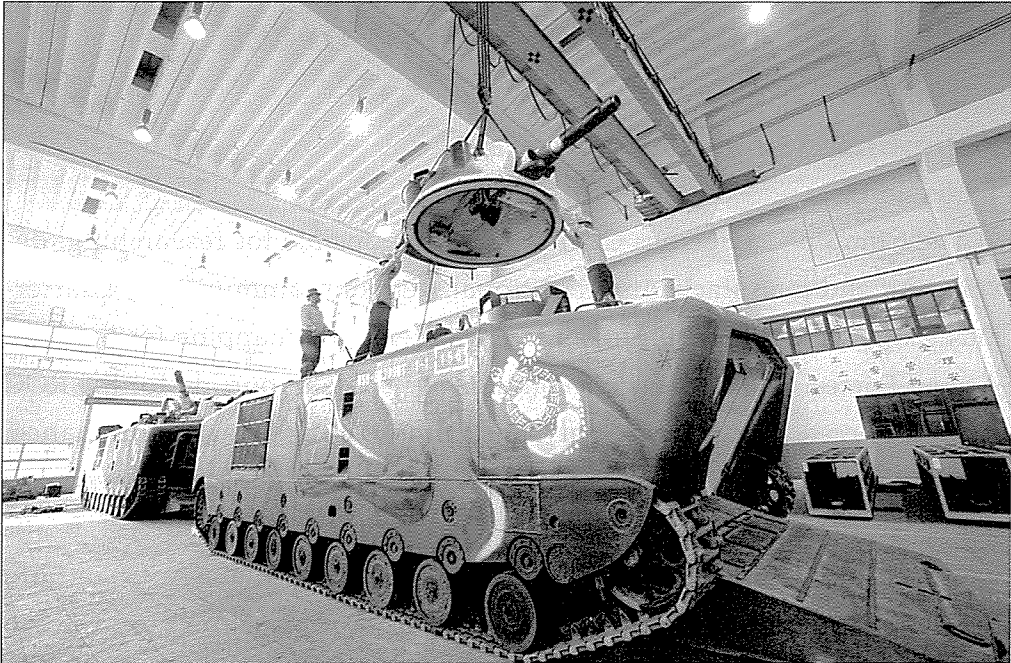

To research and manufacture ammunition for ROC Armed Forces is a vital mission to the Combined Logistics Command.

II. Reserve Command

1. Missions

In peacetime, the Reserve Command, responsible for conducting affairs regarding mobilization and civil defense and in charge of managing, organizing and offering services to the reserves, assists in military mobilization preparedness and engages in fostering the potential capability of the reserve units. In wartime, its missions are to conduct ongoing mobilization and assist in military operations, adequately meeting combat requirements of the ROC Armed Forces.

2. Current Status

(1) Strength

Approximately 5,000 people

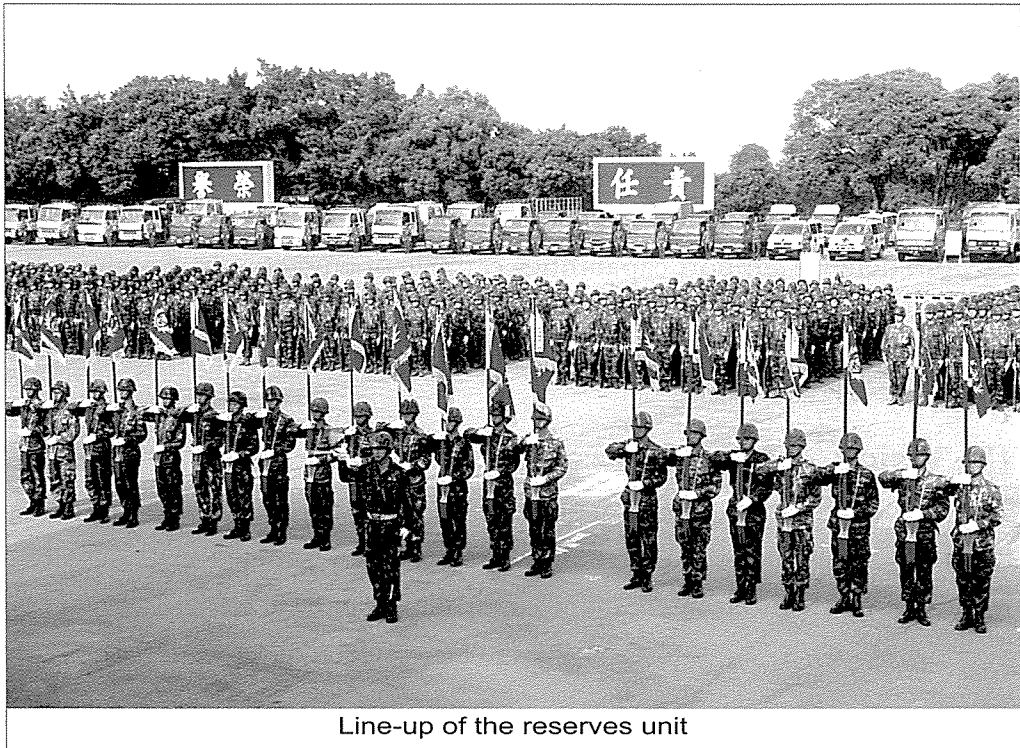

Line-up of the reserves unit

(2) Organization

(a) Under the command of the Reserve Command are Reserve Division Command, County/City Reserve Command, Reserve Mobilization Management School, Reserve Brigade and Mountain Company.

(b) Support military services units are grouped into the ones attached to County/City Reserve Command and the ones attached to the regular forces. The structure of the Units will be set up in late 2002 based upon the current system of "the Logistics featuring in supply, maintenance, transportation, hygiene and service supports" and in accordance with the principle of "systematization, professionalism and informationization." The Reserve Command will plan to effectively integrate civil resources and expert personnel by means of leasing the whole assets and personnel of a factory purposing to participate in di-

saster relief work in peacetime and assist in military services in wartime.

(3) A comprehensive coordination secretariat for all-out combat capabilities will be established within the responsibility area of each Reserves Division Command and County/City Reserve Command. The Secretariats will integrate the total combat capabilities and set up all-out defense support capabilities capable of engaging in disaster relief work within its responsibility area in line with "The Calamity Prevention and Rescue Law".

III. Vision

1. In line with the enforcement of National Defense Law and Organization Law of the Ministry of National Defense, the Combined Logistics Command is expected to transfer manufacturing, measuring, construction engineering and verifying & testing units to be overseen by Military Armament



Enhance Logistic Mechanism to Effectively Support Combat Operations

Bureau. The Reserve Command will administer the combined logistic missions based on “mission-orientation” to achieve the goals of all facilities and resources shared by the ROC Armed Forces by utilizing information technology; modern management means; simplified operational procedure, streamlined organization structure; and integrating local non-governmental resources. The Reserve Command also aims to achieve combat-related logistics support missions by improving operation quality and efficiency through the efforts of employing automatic information & resources-distribution system, consolidating supply and maintenance, actively offering transportation & supply services and overall planning & overall supply.

2. The Reserve Command is responsible for reserves mobilization, management and services with its goals laid on “improving reserves mobilization management information system;” “enhancing the mobilization pre-

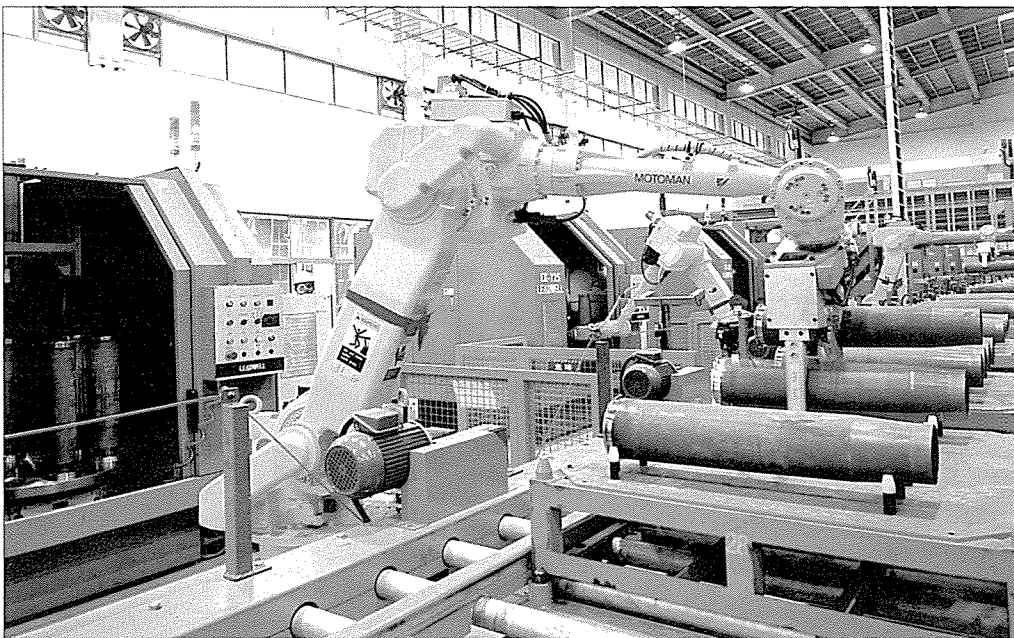

Sharpen Mobilization Process to Improve Reserve Capabilities

paredness capacity of the ROC Armed Forces;" "strengthening the reserves' combat capability;" and "integrating non-governmental resources." The Command will emphasize on "intensifying reserves education; consolidating the reserves' combat capability; mobilizing warehouses and training centers; and establishing management information system" purposing to streamline the ROC Armed Forces' mobilization; reorganize forces rapidly; and recommence combat capability quickly. The Reserve Command will continue to strengthen the capabilities of reserve brigades, reserve regiments, reserve battalions and local support military services units, implement mobilization, management and services by introducing new concepts.

PART FIVE
NATIONAL DEFENSE MANAGEMENT

Summary

1. In accordance with requirements for combat readiness and military buildup, the MND has formed comprehensive and long-term plans for military human resources and will implement various policies and projects, including those dealing with recruiting, training, promoting, transferring, retiring, reserving, evaluating, disciplining, and rewarding, so as to make servicemen satisfied with their respective military career.
2. Administration executed by law is the basic rule for implementing national defense policies. The MND will enact, amend and annul obsolete rules and regulations to achieve the goals of enhancing the legal system and establishing a comprehensive defense mechanism.
3. The management of defense budget is to effectively utilize limited financial resources to fulfill the need to strength combat readiness and warfighting capabilities.
4. Military mobilization is the most important part of national mobilization and is divided into two parts: the mobilization of the armed forces and of military supply industries. The actual work includes military transportation, mobilization, acquisition and requisition of required military materials, assistance in military operations, and holding conferences for reporting and coordinating overall military capabilities.
5. To achieve the goals of practicality, precision, and efficiency, the logistic management operational mechanism of the MND actively gathers information on capabilities of entire logistics support in terms of both quality and quantity and fully utilizes civilian resources to effectively support the ROC Armed Forces in wartime.
6. The MND will apply modern scientific methods to military internal management to well organize information about personnel, operations, time, places, and materials. In addition, the MND will pay more attention to various rights of female personnel to attain gender equality in the military.
7. The training management of the ROC Armed Forces is to combine training with combat missions; the units in each echelon are responsible for their

respective trainings that correspond to their missions. Servicemen are motivated to take more training with bountiful rewards; however, failure in such trainings will invite equivalent punishment. The process of merits and demerits will be swiftly conducted so as to encourage forces to adopt programmatic trainings.

8. The emphases on military safety disciplines management include implementing hazard prevention measures, enhancing supervision functions, improving the counseling mechanism, and keeping unhindered channels for complaints and appeals so as to early discover potential hazards, control hazardous conditions, timely deal with the aftermath, and eliminate the existence of unlawful incidents and prevent unnecessary casualties.
9. The information management of communications and electronics of the ROC Armed Forces is to grab superiority in Information and Electronics Warfare, strengthen national defense, and preempt initiative in combat. Based on peacetime and wartime concepts, the MND will set priorities and frame careful strategies for the development of military communications and electronic information management so as to seize the opportunities to overcome enemy threats.

Management of National Defense Human Resources

I. Objectives

The management of national defense human resources exists to best organize, deploy, and supervise servicemen so as to provide sufficient and qualified manpower when needed. In addition, it recognizes the individual academic and experience background so that servicemen can apply their respective specialty into work, reach their potential during terms of service, and thus the overall military human resources can be efficiently utilized to fulfill the national defense needs.

To meet the requirements of national defense, the MND has drawn up long-term and considerate plans for the management of servicemen. The application of various up-to-date policies and projects, such as for recruitment, training, promotion, duty-transferring, retirement, reservation, supervision, discipline, and reward, will help servicemen to focus on their duties without many disturbances, and thus to be content with their military career. In accordance with the national collective human resources planning concept, servicemen are encouraged to attend professional training courses so as to develop sufficient working skills and therefore form a valuable workforce to take part in the establishment of the national infrastructure after their retirement.

II. Current Policies and Implementation Status

1. Establishing Recruiting Organizations to Enroll Excellent Individuals

The cultivation of officers of the ROC Armed Forces shall aim at fostering promising candidates with international visions, technical know-how, and humanity attainment so as to create a modern and high-quality breed of officers. As a result, the recruitment for long-term military service shall



Refine Military Education of the ROC Armed Forces

be fulfilled with sufficient applicants in academies, the ROTC programs, specialized officer classes and female specialized officer classes. As for recruitment for short-term military service, it shall be fulfilled with sufficient compulsory officers, extended service compulsory officers.

Besides, in order to enhance efficiency in recruitment, academies, the ROTC programs, specialized officer classes, and military institutional classes are prioritized accordingly so as to timely offer necessary amount of officers.

2. Improving Military Education and Enhance Staff Quality

(1) Establishing a Sound Military Education System and Improve Military Education Curriculum:

a. In accordance with "Regulation of Military Education" and "Univer-

sity Law”, the MND has planned a comprehensive and continuous educational system, which is composed of four levels of military education for commissioned and non-commissioned officers, including “Preparatory Education,” “Basic Education,” “Advanced Education,” and “Superior Education.” These four levels are continuous and fully integrated in an orderly fashion so as to consolidate education efforts to yield the best servicemen. Accordingly, National Defense University has thus been established to fulfill these requirements, becoming the highest institution for military education, and the cradle to cultivate the best breed of officers.

b. Aside from with integrated university education, departments of various ROC Armed forces academies and schools have been established with “Indicative Military Characteristics” so as to blend in respective service features. These departments have designed certain considerate curriculums to provide well-rounded education for cadets.

(2) Creating an Omni-directional Learning Environment

a. The MND has established regulations for “Life-long Learning,” characterized by “studying off-duty and at one’s own expense.” Under this regulation, the primary goal for officers is to acquire master degrees, and their secondary goal is to obtain professional certificates. For NCOs, getting professional certificates is their primary goal and acquiring college diploma as a secondary one. In addition, training for sharpening personal specialties is also emphasized within this regulation to create an omni life-long learning environment.

b. Under the assistance of the Ministry of Education, the MND has entrusted Yuan-Ze University to form a strategic alliance with nine other universities to provide servicemen another choice to pursue higher education. This alliance will offer five domains as its major choices for military education (including colleges and graduate schools), such as “Business Management,” “Industrial Management,” “Information

Management," "Linguistics," and "Humanities." As a result, promising servicemen can have a better chance to share the educational resources outside the military.

(3) Promoting Second Specialty (Other Than MOS) Training

The MND has set up "Second Specialty Training Course" to provide servicemen with short-term trainings for specialty, which is not in the MOS sphere. After the training is finished, trainees are required to participate in the "National Technician Certification Examination," in order to certify their second working skill.

(4) Cultivating Competent Manpower Management Personnel

"Management Course for Ranking Officers," "Management Course for Field Officers," and "Management Course for Junior Officers" have been created by the MND to provide training on manpower management to officers in every echelon, with an eye to reach "Life-long Learning" ideal, enhance officer's leadership skills and thus increase working efficiency.

3. Improving Promotion Channels for Officer and Establishing a Reliable Personnel Administration System

(1) Creating Specialty-Oriented Promotion Channels

a. The MND has established a personnel administration mechanism to record the academic and working history, and manage the promotion of commissioned and non-commissioned officers. According to the required "Military Occupational Specialties (MOS)" of the slots, the MND has pursued the "Specialty-Oriented Promotion Channels" throughout the mechanism to cultivate servicemen with command, staff, and professional duties so that servicemen with one of these specialties will be assigned to corresponding posts to best perform their duties.

b. After reviewing relevant laws and regulations, the MND has drawn up programatic plans to reduce excess General slots and review the retention status of field officers. Since 2001, officers who are designated



Expand Occupational Sphere for Female Servicemen

with higher positions will be instated to the correspondent rank. Besides, the MND also plans to set up new posts such as “Brigadier General” and “Sergeant Major” to unclog the bottleneck of the ranking slots of commissioned and non-commissioned officers, and lower the average ages of these slots at the same time.

c. The MND has conducted comprehensive reviews to modify current specifications and serial numbers of MOSs in order to meet the needs of the new generation ROC Armed Forces. In concert with “Personnel Administration System,” “MOS Management Procedures” have been drawn up to make the promotion of servicemen coincide with their MOS so as to effectively realize the concept “select candidate and assign duty according to individual specialty.”

(2) Improving Training and Assignment Sphere of Female Servicemen

The MND continues to recruit female individuals to attend various academies and schools, or specialized classes for officers or NCOs. In addition, female officers and NCOs are gradually to be assigned to vacancies in combat and technical service units, and will be promoted through respective MOS sphere. Owing to gradual female participation in combat and technical workforce, the goal of "Gender Equality" and "Effective Utilization of Female Servicemen" can be achieved in the foreseeable future.

(3) Enhancing Leadership

The MND has promulgated "the ROC Armed Forces Guideline for Leadership" and "the ROC Armed Forces Manual for Housekeeping" to enhance internal service management. Besides, it's required that every unit has to periodically conduct "Leadership and Discipline Meeting" and "Pre-job Training" to impart leadership experience to junior officers. Superior Officers are demanded to constantly conduct inspections in subordinate units, have interaction with cadres at basic level, and maintain a solid control over these units so as to decrease the incidents of inappropriate discipline.

(4) Transparentizing Conscripts' Assignment Distribution Process

In order to clarify concerns of conscripts and their families regarding the assignment distribution process, the MND has improved assignment distribution methods for conscripts to erase such worries. In Basic Military Training Centers(BMTC), new conscripts will be classified by academic domains and professional certificates; when certain slots whose MOSs corresponding with such domains arises, the responsible units will adopt "Openly Drawing-lot" method to decide the assignments of conscripts to show the fairness in such process. Mostly, conscripts will openly draw the lots to fill the slots around their respective household location. However, slots in offshore islands will be firstly offered as lots to draw. Conscripts from families listed as requiring first-level living assistance

by local governments, those who have suffered family catastrophes, and those who have brothers serving in the military on offshore islands have the privilege to be firstly assigned to units around their respective household location. Any illegal solicitations in this regard will be turned down; therefore, the justice and fairness of the conscripts' assignment distribution can be maintained.

4. Realizing Personnel Management and Unfolding Personnel Database

(1) In concert with the policy for personnel management, the MND draws up plans to amend regulations for commissioning and conscription to revitalize the management of servicemen, prevent individuals from staying in one post for long periods of time, and therefore expand the chances for future promotion. As a result, the proposed diversified personnel management mechanism will consider age, rank, academic background, aptitude, specialty and capability of individuals to foster them through command, staff, or technical promotion channels in order to establish a plural career development for servicemen.

(2) Academic degrees, works, and professional certificates are included as the basis for assigning, managing, and evaluating servicemen so as to encourage cadres to pursue higher education and mutual learning.

(3) "The ROC Armed Forces Officer Selection and Merit Prioritization Inquiry System" is set up within the "Military Intranet (MINET)," which is a local network in the military community. After registered, officers can obtain access to this system to get one's own personnel data through its human resources database. Besides, relevant personnel officers can inquire this system offer information of suitable candidates to certain posts so as to increase effectiveness of personnel affairs. Owing to the advent of this system, the promotion processes can be fair and just, officers can have a common ground to grab promotion opportunities, and the goal of "transparency in personnel affairs" can therefore be reached.

5. Protecting the Legal Rights of Servicemen and Assisting Retirees to Get Jobs

(1) Rationalizing a Sound Salary Mechanism

Comparing with the extra pay pattern of governmental civil servants, military extra pays, such as “regional service extra pay” and “regular service extra pay,” are below their average standards. In order to obtain reasonable extra pay pattern and boost morale, the MND has been actively, through legal procedures, pursuing amendments to cover “overtime pay” and “extra pay for combat-ready operations” in this regard. Besides, with respect to rationalize current salary mechanism, proposing draft to amend “servicemen salary regulation” is already underway to erase discrepancies in salary system. .

(2) Institutionalizing Welfare Programs

For the sake of optimizing welfare programs to take good care of servicemen and their families, the MND has been working hard to institutionalize welfare programs to incorporate “National Health Insurance” and “Casualty Insurance for the ROC Armed Forces.” Additionally, the MND has established “The ROC Armed Forces Servicemen and Dependents Assistance Foundation” to help solve the difficulties faced by families of servicemen, and is planning to amend “Regulations for Military Insurance” to incorporate “Casualty Insurance for the ROC Armed Forces” in order to create a sound welfare system.

(3) Assisting in Transferring to Civilian Work and Improving Personnel Services

The MND has entrusted civilian institutions with the “Skill Certification Examination” for servicemen, and been providing job-finding assistance to those who are going to discharge or retire. Understaffed civilian enterprises will be contacted and assisted by the MND to take part in job-finding activities to look for potential candidates to fill vacant posts.

In addition, local service centers for servicemen are demanded to maintain high efficiency to enhance quality of personnel services.

6. Establishing A Prospective Military Career

During terms of service, servicemen may get promoted to higher positions by hard work, diligence and obtaining relevant academic backgrounds. Servicemen can pursue their own goals through command or staff channels and stride into respective future, whether it's in military or not.

By receiving further and advanced education, servicemen can master the skills of leadership, managing, fighting, and instructing during their terms of service. Owing to these considerate educations, servicemen can not only develop logic and independent thinking skills, but also accumulate knowledge necessary to their work. In addition, attendance at National Open University, open junior colleges, open junior colleges of commerce, night school, and continued education programs for bachelor's and master's degrees for advanced education during off-duty times is encouraged for servicemen. Furthermore, several institutes, schools and training centers in the military are offering vocational training to help foster second skill for servicemen.

During military service, military personnel can accumulate professional skills, such as command, management, combat, and training, produce dependent thinkings, and establish logical capabilities through more advanced military educations. In addition, servicemen can study in "Open Junior College for Administration," "Open Junior College for Commerce," "National Open University," night school of technical institutions, and credit classes for bachelor or master degrees during off-duty hours. They can also attend trainings for military-civilian dual-use technologies offered by the military training centers so as to cultivate their second specialties and obtain relevant technical certificates.

In light of yielding a prospective life after military service, servicemen can switch to governmental positions or acting as drillmaster officers in public educational organizations through legal procedures or examinations. Before retirement, servicemen can participate in vocational training or receive employment assistance according to their free will in order to help them quickly enter the civilian workforce.

III. Vision

1. Refining the Quality of Servicemen and Making the Best Use of Their Specialties

(1) Cultivating professional servicemen is the MND's first priority. In order to reach the goal of "quality above quantity," the performance of cadets will be strictly monitored, and those with inferior grades will soon be dismissed from military academies and schools; quality of faculty members and curriculum design will be enhanced; finally, evaluation on education efforts will be conducted. In line with the policies of "Twelve-year National Compulsory Education" and "National Science and Technology Education," the MND has gradually transformed NCO schools into junior colleges to yield professional NCOs. As for officers, the promotion will depend on their respective MOS, such as command, technical, staff, etc. Supervision upon their promotions will be strictly conducted to sift out unsuitable candidates in order to make servicemen develop prospective future through respective ability.

(2) To improve the status of NCOs, the MND will gradually establish a system for professional NCOs to help them acquire junior college degrees and replace certain officers in administrative and technical realm. Besides, the MND will draw up "Well-Rounded Life-Long Learning Project for Military Cadres" in line with "National Certification System" and the promotion of the "Skill Certification Examination" to help NCOs acquire professional certificates. Through these thorough considerations,

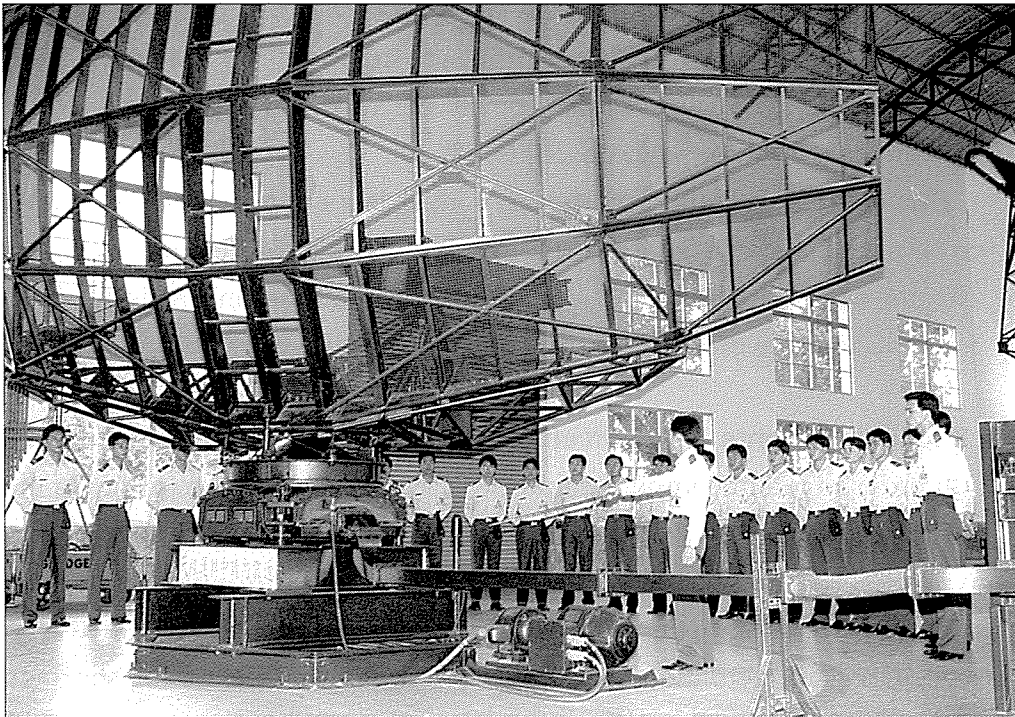

Enhance Quality of Servicemen and Perform Professional Skills

the MND hopes to provide a better learning environment for NCOs and enhance their technical skills.

2. Making Servicemen Database Transparent

Personnel vacancies database will be available to all servicemen via the “MINET” system in the coming years. Certain enchain vacancies with reasonable and just prioritization statuses of potential candidates will be shown in the “MINET” in order to exhibit the fairness in personnel affairs. Those vacancies are openly up for grabs among servicemen with qualified status so as to justify the new personnel management system.

3. Creating Database of Military Human Resources

(1) The information for human resources of reservists will be collected and categorized to create a personnel MOS database. Besides, a servicemen distribution mechanism will also be proposed to provide an important reference for military mobilization and combat preparedness regarding five-year MOS requirement for new conscripts.

(2) Envisioning the future, military personnel data system will be restructured to be an exchangeable database. Besides, the "Inquiry System for Officer-in-charge" will be established to incorporate such database in a real-time fashion so as to make the database fully match with the status quo.

4. Expanding Rights for Servicemen and Retaining Excellent Individuals

In order to retain competent and experienced servicemen to stay in the military, their salary and welfare will be increased, and the working environment and management will also be improved. Through these efforts, the MND is making the option of staying in the military more attractive to excellent servicemen, thereby helping to diminish the personnel shortage in lower echelons of the military and strengthening the overall combat capability of the ROC Armed Forces.

5. Helping Servicemen to Plan Their Careers and Encouraging Life-Long Learning

While the government is promoting concepts like "Society of Learning" and "National Specialty Certification," officers will be encouraged through various off-duty learning activities to pursue master's degrees or second specialty other than MOS, and NCOs will also be induced to get national specialty certificate through necessary examinations. Based on these plans to increase academic and technical expertise for servicemen, they are expected to plan their respective career whether or not staying in the military, and they can quickly find a job as soon as a decision on retirement is made.

Management of National Defense Regulations

I. Objectives and Policies

The foundation of the ROC Armed Forces' establishment depends on a solid and sound defense mechanism. This mechanism is so formed on the basis of specific and complete defense regulations and rules. In the meantime, pursuing legal procedures is the basic principle to manage defense affairs according to experiences gained in the progress in democracy and law of the ROC government. Based on regulations laid down by Executive Yuan, the MND will conduct programs to amend outdated and obsolete defense regulations and rules through legal procedures so as to make a well-defined and well-founded defense mechanism.

II. Implementation Status

1. Making Enactments, Amendments and Annulments

From July 2000 to June 2002, the MND has enacted 38 new laws and regulations (Table 5-1), such as "Regulations for All-out Defense Mobilization," amended 64 current laws and regulations (Table 5-2), such as "Organization Law for the Ministry of National Defense," and annulled 55 outdated laws and regulations (Table 5-3), such as "Regulations for Classification of Servicemen." Up to June 30, 2002, there are 147 valid and effective defense regulations and rules.

2. Making Enactment and Amendment of Important Regulations and Rules

(1) Enacting and Amending Subsidiary Regulations for the National Defense Law and Organization Law of the MND

Table 5-1 Regulations and Rules Enacted from 2000 to 2002

Enrollment Regulations in Military Junior and Senior High Grades Preparatory School	Organizational Regulations for Artillery and Missile Personnel School
Regulations for Rights, Obligations, and Management of Self-Funding Cadets	Organizational Regulations for Armor School
Regulations for Determining the Level of Disabilities of Servicemen	Organizational Regulations for the Army Engineering School
Management and Assignment Regulations for Replacement Servicemen and National Guardsmen Before the Amendment to Military Service Law	Organizational Regulations for Military Communication and Electronic Information Personnel School
Regulations for Allowances for Dependents of Deceased Decorated Servicemen, Injured and Disabled Servicemen and Dependents of Deceased Servicemen	Organizational Regulations for the Military Chemical School
Regulations for Military School Graduate Students	Organizational Regulations for Military Logistic School
Regulations for Investigating Personnel in Charge of or Involved with National Defense Security	Methods for Developing, Producing, and Maintaining Products by the MND Technological Institutions and Private Sectors
Regulations for Individuals Exempt from Regular Military Service due to Below Standard Physical Conditions	Methods for Marketing and Selling Products by the MND Technological Institutions
Organizational Regulations for Air Force Academy	Regulations for the Management of the Private Sectors by the MND Technological Institutions
Organizational Regulations for Navy Technical School	Organizational Regulations for Chung Cheng Military Preparatory School
Organizational Regulations for Marine Corps School	Organizational Regulations for Political Warfare Academy
Organizational Regulations for the Air Force Aviation Technical School	Organizational Regulations for General Political Warfare Bureau
Organizational Regulations for the Naval Academy	Organizational Regulations for Comptroller Bureau
Organizational Regulations for Reserves Mobilization Management School	Organizational Regulations for Military Medical Bureau
Organizational Regulations for Military Police School	Regulations for Activities of the Office of General Staff
Regulations for Servicemen not Required to Return to Military Service	Regulations for the Activities of Comptroller Bureau
Organizational Regulations for Military Intelligence School	Regulations for Activities of the General Political Warfare Bureau
Regulations for Extolling and Interring Servicemen Killed in Action Regulations for All-out Defense Mobilization	Regulations for Activities of the Medical Bureau
Organizational Regulations for Infantry School	Organization Regulations for the National Army Senior High School
Bylaws for Drafting Civilian Personnel in All-out Defense Mobilization Exercise	

Source of Duration: July 1, 2000-June 30, 2002

The “National Defense Law” and the “Organization Law of the Ministry of National Defense” have been promulgated by the President on January 29th, 2000, and the above two laws are required to be officially implemented by Executive Yuan within the next 3 years. To ensure that the new laws are enacted as scheduled, the MND has not only amended and promulgated relevant organizational regulations for each GHQs, but also drawn up subsidiary regulations, such as the “Amendments to Organizational Regulations for the MND HQs and the GSH” (later amended

Table 5-2 Regulations and Rules Amended from 2000 to 2002

Implementation Bylaws for the Air Defense Law	Implementation Bylaws for the Service Regulations of the Officers and NCOs of the ROC Armed Forces
Implementation Bylaws for Military Officer and NCO Promotion Statutes	Implementation Bylaws for the Enforcement of Act for Settlement of Bestowal of Farmland to Warfighters
Regulations for Evaluating Military Officer and NCO	Implementation Bylaws for the Pension & Compensation for Bereaved Families of Servicemen
Regulations for Implementing Military Service Law	Regulations for the Hiring Civilian Employees in the Military
Service Regulations for Dropping out, Suspending, and Expelling Military School Student	Regulations for Sustaining and Utilizing the Production and Service Funds of the ROC Armed Forces
Organizational Regulations for the General Headquarters of the Army, MND	Regulations for Sustaining and Utilizing for Rebuilding Old Quarters Funds of the ROC Armed Forces
Organizational Regulations for the General Headquarters of the Navy, MND	Regulations for the Pension & Compensation for Bereaved Families of Cadets in the Academies of the ROC Armed Forces
Organizational Regulations for the General Headquarters of the Air Force, MND	Regulations for Suspension of Pensions Regarding Retired Officers and NCOs Taking Positions in the Public Sector
Organizational Regulations for the Combined Logistics Command, MND	Regulations for Other Pensions and Compensation of Retired and Discharged Officers and NCOs
Organizational Regulations for the Reserve Command, MND	Regulations for Duty Transferring of Officers and NCOs of the Armed Forces
Organizational Regulations for the Military Police Command, MND	Education Methods for Prevention of Child and Youngster Sexual Abuses
Service Regulations for Regular Forces and Replacement Servicemen	Standard of Verification for Handicapped Servicemen
Implementation Bylaws for Military Officer and NCO Assignment Statutes	Regulations for Servicemen Not Required to Return Service
Regulations for Military Officer and NCO Evaluation and Awards	Methods for Commemoration and Commendation of Servicemen Killed in Action
Regulations for Military School Cadets' Studies	Management Methods for Property of Deceased Servicemen without Dependents
Implementation Regulations for ROTC Selection, Training, and Service	Management and Punishment Methods for Employment of Military Vehicle
Statute for Rebuilding Old Quarters for Dependents	Methods for Treatment for Dependents of Servicemen Killed in Action
Regulations for Managing and Using Rebuilding Old Quarters for Military Dependents Funds	Organization Regulations for Reserve Mobilization Management School
ROC Armed Forces Criminal Law	Implementation Bylaws for Rebuilding Old Quarters Funds of the ROC Armed Forces
Implementation Regulations of Compulsory Officers and NCOs' Selection and Training Program	Operation Bylaws of the Ministry of National Defense
Implementation Regulations for Servicemen Studying in Respective Units or in Civilian Institutions	Management Methods for Having Guns for Self-defense
Regulations for Military Officer and NCO Evaluation and Awards	Methods for Granting Certificates for Military Vehicles
Organizational Regulations for the MND General Staff	Regulations for Preferential Saving Rates of Retired and Discharged Servicemen of the Armed Forces
Leave Regulations for Military Officers and NCOs	Stamp Rules of the Armed Forces
Regulations for Selling or Handling Old Quarters for Military Dependents and Lands Unsuitable for Military Barrack	Regulations for Controlling Toxic Materials in Military Units
Reserves Management Regulations	Implementation Bylaws of Evaluation of Performance of the Officers and NCOs of the Armed Forces
Assembly Regulations	Organizational Regulations for the Air Force Academy
Military Judicial Law	Organizational Regulations for the Air Force Aviation Technical School
Organization Law of the Ministry of National Defense	
Pension and Subsidies Regulations for Retired and Discharged Officers and NCOs	
Regulations for Servicemen's Registration	
Implementation Bylaws for the Servicemen Insurance	
Implementation Bylaws of Awards of the Officers and NCOs of the ROC Armed Forces	

Source of Duration: July 1, 2000-June 30, 2002

Table 5-3 Laws and Regulations Abolished from 2000 to 2002

Regulations for Assigning Military Personnel	Organizational Regulations for Military Athletic Association
Military Personnel Receive Journalists Regulations	Organizational Regulations for Reserved Officer Second Round Selection Committee
Regulations for Selection and Training Personnel Receiving Journalists	Implementation Regulations for Military Supervisory Affairs
Military Jail Management Regulation	General Principle for Reservist Association
Military Real Estate Management Regulation	Regulations for Disposing Military Discarded or Unsuitable Materials
Regulations for Controlling Military Accountant and Statistician Assignment	Regulations for Reeducate Prisoners In Military Jails and Prisons with Doctrines
Regulation for Setting Up Counseling Institution and Counselor Selection for Reservist	Regulations for Enacting and Managing Defense Regulations
Measurement Regulation	Military Personnel Deposit Regulation
Implementation Regulations for Military Personnel to Obtain Information from Local Governments and Professional Institutions	Regulations for Live Fire, Territorial Sea and Air Space Security, and Ammunition Control
Regulations for Mailing Confidential Documents	Rules for Military Personnel Physical Condition Classification
Regulations for Using Documents for Military Prosecutor to Direct Police Who Enforce Martial Law	Regulations for Emergent Transport through Railway or Highway
Regulations for Qualifications of Graduates of Chung Cheng Armed Forces Preparatory School	Regulation for Leave Port Process and Checks of Ships from Taiwan, Penghu, Kimmen, and Matzu
Regulations for Decorating and Assigning Special General	Regulations for Urgently Repairing Railway and Highway in Taiwan During Wartime
Regulations for Garrison	Regulations for Military Personnel Promotion
Regulations for Overseas ROC Students to Enroll in National Defense Medical Center	Regulations for Controlling Domestic and Foreign Aviation and Auxiliary Facilities for Navigation During Urgent Times
Regulations for Military Personnel Pay	Regulations for Joint Examination of Military Airport
Implementation Regulations for Extending Terms of Service During Wartime	Regulations for Regular NCO Classes in Military School to Screen High School Graduates
Regulations for Military Hygiene Affairs	Regulations for Paralleling NCO Diploma to High School, Vocational School Diploma
Regulations for Guarding Affairs	Regulations for Ports Control in Taiwan
Regulations for Applying for Military Personnel Disaster Assistance in Taiwan	Regulations for Domestic and Foreign Flight Application and Control in Taipei FIR
Regulations for Domestic and Foreign Aviation Forced Landings in Air Bases	Regulations for Awarding Combat Rewards
Controlling Regulations for Foreign Warship Entering ROC Ports	Regulations for Interring Military Personnel Died in Battle and Handling Their Relics
Regulations for Awarding Military Personnel Injured During Wartime	Regulations for Interring Deceased Military Personnel in Martyrs' Shrine
Regulations for Conferring Commendation to Military Personnel Killed During Wartime	Implementation Regulations for All-Out Defense Mobilization
Regulations for Wedding Allowances for Military Personnel with Merits	Regulations for Military Cemetery Management
Regulations for Controlling and Using Public and Private Communicating Facilities in Taiwan	Methods for Producing Military Products by Private Sectors
Regulations for Constructing and Maintaining Military Structures	Rule for Control and Application of Manufacturing and Service Operation Fund of the ROC Armed Forces

Source of Duration: July 1, 2001-June 30, 2002

as Organizational Statutes for the MND HQs and the GSH), article 9 paragraph 1 of the "Amendment to Organization Law for the MND," "Organizational Statutes for the General Political Warfare Bureau, MND," "Organizational Statute for the Comptroller Bureau, MND," and "Organizational Statutes for the Medical Bureau, MND." In accordance with legislative procedures, the above regulations were sent to the Executive Yuan for confirmation, then to the Legislative Yuan for legal authorization during the sixth sitting of the fourth session of legislators.

The MND has submitted the "National Defense Law," the "Organization Law of the Ministry of National Defense," and other subsidiary regulations to the Executive Yuan. These laws and regulations, which became effective on March 1, 2002, will help to establish a modern, and technical defense operational mechanism. Therefore, the goal of utilizing the nation's workforce to assist in national defense affairs will be realized.

A bill entitled "Organizational Regulations for the MND Military Armament Bureau" was also sent to the Legislative Yuan during the 4th session; however, its legislation was unable to be completed. Besides, according to Article 13 of the "Function Exercise Law of Legislative Yuan" amended on November 14, 2001, it cannot be discussed in a successive legislative session. Therefore, the MND will review this bill and, through legal procedures, propose the revision first to the Legislative Yuan for legal authorization. It is hoped that through the enactment of the bill, a professional military armament system for modern national defense system will then be born.

(2) Drawing up "Regulations for All-out Defense Mobilization"

In order to realize the "all-out defense" concept as manifested in the National Defense Law and construct a national mobilization mechanism based on the status quo, the MND, following the guideline laid down by the Executive Yuan and opinions solicited from relevant governmental

organizations, have drafted "Regulations for All-out Defense Mobilization." The draft was passed by Legislative Yuan, and promulgated by the President on November 14, 2001. In order to conform to the regulations, several subsidiary regulations were also created with an aim to consolidate all civilian manpower so as to fulfill the "All-out Defense" concept and form the primary basis for mobilization of all governmental organizations.

(3) Amending Regulations for Servicemen Aimed at Restructuring Personnel Mechanism

Concerning the effective management of military human resources and the promotion of restructuring servicemen management mechanism, the MND has conducted "The ROC Armed Forces Refining Program," streamlining servicemen to best fit the national defense. After thorough consideration, the MND has drawn several new bills, such as "Amendments to Officer and NCO Commission Statutes," "Amendments to Officer and NCO Service Statutes" and the "Amendments to Military Officer and NCO Assignment Statutes," in order to restructure the mechanism of the management of officer and NCO. These bills have already submitted to Legislative Yuan for legal authorization. It is hoped that the reconstruction of servicemen management mechanism will therefore be fulfilled after the legal process is done.

(4) Amending Supplementary Military Service Regulations to Strengthen the Military Service Administrative System

In accordance with government "Alternative Service" policy and the consideration to maintain a capable military force, the MND has drawn up relevant amendments to the "Military Service Law" and the "Regulations for Implementing Military Service Law" to strengthen the military service administrative system. The amendments were sent to Legislative for legal authorization, and promulgated by the President. Besides, in order to further improve this administrative system, the MND has es-

established "Management and Assignment Regulations for Replacement Servicemen and National Guardsmen Before the Amendment to Military Service Law" and "Regulations for Exemption of Service for Conscripts," and amended "Regulations for Calling Up Reserves," "Reserves Management Regulations," "Regulations for Exemption and Postponement of Conscription" and "Regulations for Selection and Service" so as to make the overall military service administrative system sound and solid.

III. Vision

Under the national environment pursuing democracy, law and order, every operation supervised or conducted by the MND has to be in accordance with relevant laws and regulations. Furthermore, with an increasingly diversified and intricate military administrative system, national defense affairs might have involved rights and obligations of civilian. As a result, the MND will continuously review national defense regulations to ensure that they all conform to the ROC constitution and laws, amend outdated and irrelevant regulations, fulfill requirements of military administration and combat readiness, and, at last, assert the rights of the people.

2002
NATIONAL DEFENSE REPORT

Management of National Defense Expenditures

I. Objectives and Policies

1. Objectives

The purpose of management of defense expenditures is to make the most of military financial resources so as to fulfill defense missions, implement policies in terms of time, quality, and quantity while effectively utilizing limited financial resources to ensure readiness and strengthen combat capabilities through an efficient management system.

2. Policies

(1) Consolidating Various Accounting and Financial Systems:

Concerning changes in the world and developments in business, all accounting and financial systems and relevant laws and regulations are to be modified or amended to establish a better accounting and financial processing system so as to effectively assist relevant decision-making process.

(2) Developing “Budget Management Information System:”

National defense policies and plans are expressed in the defense budgetary plan. As a result, the MND has set up “Budget Management Information System” within “MINET” network to refresh and provide real-time information for decision-making officers so as to keep them abreast of implementation status of relevant policies so as to achieve goals prescribed by the budgetary plan.

(3) Executing Effective Internal Audits:

The principles of “administration enforced by law” and “expenditures spent by law” are strictly adhered to by the MND. The outcome of implementation of various defense policies is effectively supervised and then

used as viable reference for future budgetary plans and expenditure allocations so as to improve internal auditing and management.

(4) Reinforcing Cost-effective Awareness and Evaluation

The concept of "cost-effectiveness" is incorporated within the management of defense expenditures to locate cost-related factors and establish internal cost-effective evaluation standards as well as methods. Thus, during budgetary implementation phases, these standards and methods can act as a best reference for decision-makers so as to make the most of overall defense resources and meet the defense policy objectives.

(5) Rather than established on a profitable basis, the MND special funds are managed on the basis of self-reliance so as to lower the relevant costs as well as the dependence on the defense expenditures.

II. Implementation Status

1. Accounting Management of Defense Expenditures

(1) The MND has examined the applicability of all accounting regulations and modified 11 accounting regulations (as listed in table 5-4), such as "Accounting Operational Regulations for the MND Assets," in accordance with status quo of military developments so as to improve overall accounting management.

(2) The MND has formulated "Regulations for Internal Audits" for auditors to conduct their duties, and offered "Courses for Military Internal Management and Audit" to relevant auditors to enhance their know-how. Furthermore, the MND has published "Pamphlet for Military Internal Audits" relevant officers with an aim to enhance internal management and fulfill the principle of "Administration Executed by Law" and "Expenditures Spent by Law" so as to bring about a comprehensive reform in the military accounting system.

2. Funds Management

Table 5-4
Amended Regulations for Accounting Management of Defense Expenditures

No.	Regulations
1	Accounting Operational Regulations for the MND Assets
2	Operational Regulations for Certificates of Expenditure
3	Regulations for Processing Agency Receipts by the ROC Armed Forces
4	Operational Regulations for Accounting for Navy Shipbuilders
5	Regulations for Using and Safekeeping Uniform Receipts
6	Detailed Operational Regulations for Operations and Maintaining Cost Calculation Systems by the ROC Military
7	Safekeeping Limitations for Certificates and Account Books Regarding Budget in the ROC Military
8	The ROC Military Operations and Cost Calculation Maintenance System
9	Operational Regulations for the Handing Over of Duties for Accountants and Cashiers in the ROC Armed Forces
10	Domestic Travel Report and Certificates for Travel Allowance
11	Categories of Subsidies and Limits for Servicemen Studying Abroad

Source of Duration: July 1, 2000-June 30, 2002

(1) In accordance with development in accounting affairs, the MND has amended several out-of-date regulations, such as "Outline for Planning Final Accounts for Special Funds of the MND Subordinate Units," "Regulations for Reviewing Accounting Monthly Reports for Special Funds of the MND," "Regulations for the Management of Banknotes and Securities of the ROC Armed Forces Production and Service Fund," and "Draft of the Outline for Accounting System of the ROC Armed Forces Production and Operation Funds," so as to strengthen military accounting mechanism and internal management of funds.

(2) In order to have a clear picture on the status quo of various production and service units of the ROC Armed Forces and have a sound management on them, the MND, according to regulations as stipulated in

Article 24 of the "Outline for Budget Implementation by Agencies Affiliated with the Central Government," has framed a plan for supervision and management, which demands relevant officers conduct on-site supervision so as to control costs, enhance management and reach annual defense budget goals.

(3) The MND will randomly dispatch personnel to conduct cash checks upon units operating special funds so as to keep better cash management, reduce financial risks and maintain the security of funds.

III. Vision

The MND will continuously conduct reviews on relevant regulations and rules regarding defense financial accounting and auditing processes, so as to make them meet changes as time flies and management evolves. Furthermore, the MND will spare no efforts to enhance the management of defense expenditure and the flexibility in operating defense funds in the hope to increase productivity, decrease cost, lower dependence on defense expenditures and at last reach the goals laid out as follows:

1. Comprehensively examine all accounting systems and relevant laws and regulations to establish a better system for accounting management and strengthen financial management.

2. Continuously enhance internal accounting management and exercise the active functions of control, management, and service in line with the trends to adjust defense organization, pursue information technology and strengthen internal management.

3. Widely review and adjust operating status of national defense funds according to relevant functions and division of labor in order to best utilize special funds. It is hoped that during times of tight budget, defense funds can be combined with limited defense budget to attain the best economic effect of the integrated defense financial resources.

Management of Military Mobilization

Military mobilization is the most important part of national mobilization and is divided into two parts: the mobilization of the armed forces and of military supply industries. In addition, its actual work includes military transportation mobilization, acquisition of required military materials, assistance in military operations, and reports regrading overall military capabilities.

I. Mobilization of the ROC Armed Forces

The mobilization of the ROC Armed Forces includes disaster assistance and mobilization for defense or combat. In peacetime, a mechanism is developed to allow the military to work with the general public in the event of disasters. All necessary preparations for mobilization are finished so as to provide support as needed in times of disasters. In wartime, all people and resources are quickly mobilized so as to bring the ROC Armed Forces up to optimal combat readiness and assist in completion of various combat missions.

1. Reserve Forces Management

The reserve forces are a very important part of overall national military capabilities and need to be well organized in consideration of both defense security and economic development for the sake of having adequate servicemen in the event of war. In 2001, the MND listed 3,500,000 reservists (over 2,700,000 in the army, over 400,000 in the navy, and more than 300,000 in the air force) consisting of over 300,000 officers, over 1,400,000 NCOs and more than 1,700,000 conscripts.

2. Mobilization Methods

According to wartime requirements regarding servicemen, young, trained reservists with specific specialties are selected and enlisted into the “Annual Plan for Armed Forces Mobilization” every year. There are three approaches to mobilize reservists, including “Mobilize According To Actual Vacancies,” “Mobilize Beyond Actual Vacancies” and “Mobilize According to Combat Attrition.”

(1) Mobilize According To Actual Vacancies

On-call Reservists are mobilized within 24 hours to fill the vacancies in regular forces.

(2) Mobilize Beyond Actual Vacancies

On-call Reservists have to report to duty within 24 hours, and are fully equipped within 48 hours to expand reserve combat units other than regular forces so as to maintain long-term combat capabilities.

(3) Mobilize According to Combat Attrition

On-call Reservists are mobilized within 24 hours to replenish vacancies due to combat attrition.

3. Training of Reservists

(1) Training Muster-call

a. Training Muster-call is the one of the primary methods for improving the capabilities of reservists in peacetime. By law, reservists have to receive at the best of 4 times of trainings within 8 years after they have been discharged from the military. Furthermore, every session of training will not exceed 20 days. However, considering that national economic development desperately needs abundant manpower to take part in, training sessions actually last for only 5 to 7 days.

b. Training for reservists emphasizes MOS refresher courses, live fire exercise, and specialty tests. During training muster-calls in 2000 and 2001, more than 160,000 reservists, belonging to the group of “Mobilization According To Actual Vacancies” and the group of “Mobilization

Beyond Actual Vacancies," were called up.

(2) Review Muster-call

a. A verification system using registered mail is used regarding reservists who are selected and enlisted into the "Annual Plan for Armed Forces Mobilization" and have yet to be called up for training in order to confirm their specialties and basic information. Thus, it's not necessary for reservists to report to their units. In 2000, the verified data of 560,000 people were received by the MND.

b. In 2001, the registered mail verification system was temporarily suspended. All battalion level units (or independent company units) sent servicemen to visit reservists enlisted in their units to acquire data needed so as to have the latest information of every reservist.

II. Mobilization of Military Supply Industries

Military supply industries mobilization is the selection and organization of qualified civilian factories to establish a military supply industries production and maintenance system to carry out readiness operations to enlarge production and maintenance capabilities and meet military needs in wartime.

1. System

With emphasis on choosing domestic factories with good production and maintenance capabilities in terms of quality and quantity and equal emphasis on both production and maintenance, the central factories of all service branches select factories which are nearby and qualified to manufacture military materials and integrate them into a mobilization production system focusing on the manufacture and maintenance of the final assemblies or sub assemblies of weapon and equipment.

2. Organization

In accordance with the battle requirements of the service branches, the

MND prepares and implements the Plan for Military Supply Industries Mobilization every year. In 2000, more than 300 factories were mobilized, more than 100 production systems set up, and more than 500 types of military supply items produced by mobilized factories. As for the data in 2001 in this regard, above 100 factories were mobilized, above 80 production systems were set up and above 400 types of military supply items were produced.

III. Mobilization of Military Transportation

The objective of military transportation mobilization is to make use of civilian transportation, machines, and tools to supply transportation equipment to regular and reserve forces in order to support tactical movements and battlefield activities. Operational priorities lie first in remedying the lack of transportation equipment, then in setting up battlefield activities and in utilizing unsuitable and obsolete vehicles to alter the appearance of the terrain of possible landing sites and beaches.

1. System

Reserve Division Commands and Reserve Regiment Commands are responsible for coordination of drafting vehicles, heavy machinery for construction and motorized fishing boats. On the other hand, GHQs of each service are in charge of coordination of drafting motorized fishing boats and ships, which are over 200 tons, and civil aircraft. These units have to coordinate with various public and private sectors in order to facilitate the drafting processes so as to fulfill demands and requirements regarding those vehicles. Organizations including traffic supervision units, civilian airlines, and police departments are responsible for actually executing drafting processes, while military units of all service branches are to take what is collected and make the best use of it.

2. Organization

In line with the battle requirements of all service branches, the MND prepares and implements the “Plan for Military Transportation Mobilization” annually. In 2000, more than 46,000 vehicles of all kinds, over 600 heavy machines, over 200 ships, over 300 motorized fishing boats, and over 100 aircrafts were mobilized. As for the data in 2001 in this regard, vehicles over 42,000, heavy machines over 1000, ships over 300, motorized fishing boats over 500 and aircraft over 20.

IV. Requisition of Required Military Materials

The objective of requisition of required military materials is to acquire necessary items or fixed facilities from private sectors, which cannot be obtained through normal means, so as to satisfy the urgent needs during emergencies or war times.

1. System

County / City Reserve Commands are responsible for coordination of necessary items or fixed facilities. Local governments are responsible for actually executing drafting processes, while military units of all service branches are to take over those what is collected items or fixed facilities and make the best use of them.

2. Organization

In line with the battle requirements of all service branches, the MND formulates the “Plan for Drafting Required Military Materials” annually. It consists of 9 categories: Machinery, Chemical Material, Mineral Material, Metal Material, Construction Material, Transportation Material, Fiber & Rubber Material, Medical & Hygienic Material as well as Fixed Facilities. In 2000, a total of 131 important materials in 7 categories were acquired and more than 20,000 fixed facilities, such as classrooms, school auditoriums, warehouses, stadiums and activity centers, were drafted for military usage. In 2001, more than 300 important materials in 7 categories

were acquired, and more than 20,000 fixed facilities, including classrooms, school auditoriums, gyms, stadiums, playgrounds, activity centers, drafted for military usage.

V. Mobilization for Assisting in Military Services

Reservists are mobilized to assist in military operations, such as urgent repair of damaged military facilities, participation in battlefield activities as well as transportation of military materials in order to remedy shortages in regular servicemen.

1. System

The GHQs of each service, the Medical Bureau of the MND, and the public sector are responsible for drafting reservists and determining the scale of assistant military service groups. County / City Reserve Commands are in charge of actual implementation and the organization, management and assembling of these on-call reservists. On the other hand, military units and government agencies are responsible for mustering them and assigning their missions respectively.

2. Organization

To meet the wartime needs of the GHQs of each service, the Medical Bureau of the MND, and the public sector, the MND prepares the "Personnel Mobilization Plan for Assisting Military Services" annually. In 2000, the plan focused on national guardsmen enlisted by local governments, and more than 50,000 individuals were assembled and organized into 235 squadrons and 418 independent area teams. In 2001, the plan was altered to put primary emphasis on replacement soldiers enlisted by County / City Reserve Commands and secondary emphasis on reservists, and more than 55,000 people were organized into 248 squadrons and 495 independent area teams.

3. Training

The training courses emphasize military operations needed by units with new personnel. In 2000, more than 4,000 people from 31 squadrons and 9 independent area teams were assembled and trained. In 2001, over 3,000 people from 23 squadrons and 5 independent area teams received training.

VI. Coordination Conferences for All-out Combat Capabilities

“Coordination Conferences for All-out Combat Capabilities” are a mechanism used to bridge the coordination and cooperation gap that exists between the government and the military. The objectives are to gather civilian materials in war zones and fully integrate the military, local government and organizations to carry out military and civilian cooperative defense to support combat in wartime and help in peacetime disaster assistance.

1. System

Conferences for combining and coordinating combat capabilities are divided into three levels: first, the Taiwan and Fukien Area; second, combat theaters and third, counties and cities. Conferences of these three levels are respectively convened and chaired by the commander of Reserve Command, commander of each combat theater and head of the county or city government. And the secretariat for each level is staffed by the Reserve Command, County / City Reserve Commands.

2. Organization

In order to successfully carry out objectives, “Coordination Conferences for All-out Combat Capabilities” for “all-out defense” mobilization in the Taiwan and Fukien Area consist of nine combat theaters (including the two special municipalities of Taipei and Kaohsiung) and 20 counties and cities. Every conference has a secretariat, a political affairs division, a police affairs division, a military affairs division, and a organizational training di-

vision to integrate the powers of the government, the military and organizations in theaters to complete mobilization preparations, integrate capabilities and quantities of personnel, and materials and support military operations.

VII. Mobilization Exercises and Training

1. ROC Armed Forces Mobilization Exercises

The objective of the ROC Armed Forces mobilization exercises is to validate the effectiveness of "timely mobilization for combat" capabilities. The MND orders mobilization through the broadcasting media and the combat command system. It also carries out various personnel and materials mobilization exercises in line with the exercises and training of regular forces. In September of 2000, over 6,000 individuals participated in the Tunghsin No. 12, Vehicles Mobilization No. 6 and Ships Mobilization No. 3 exercises. Over 200 trucks and heavy machines and 6 motorized fishing boats were drafted. In May 2001, the Tunghsin No. 13 Exercise was launched (including personnel, materials and vehicles mobilizations) with a total of more than 4,000 participants and 30 trucks drafted.

2. Military Supply Industries Mobilization Exercises

The objective of military supply industries mobilization exercises is to verify whether or not local government and public and civilian factories can effectively supply all military factories and warehouses and familiarize themselves with production transformation and maintenance operational procedures in wartime. In July 2000, more than 600 people from 4 logistics units, several local governments, and many local institutions participated in the Tzuchiang No. 18 Exercise. In April 2001, the Tzuchiang No. 19 Exercise was carried out with more than 700 participants from 4 logistic factories, warehouses and supply transportation units, the Kaohsiung City Government and mobilization factories.

VIII. Improvements in Reserve Mobilization

1. Improvement in Reservists Management

To satisfy the need for young servicemen and experienced specialized personnel, Starting from 2002, the MND lists the 1 million individuals under 30 years of age, who are strong and well trained, as the main body for the reserves. The focus of adjustments in personnel selection and recruitment policy are as follows. Compulsory reservists are subject to selection and recruitment within 8 years after discharged from the military. Senior specialty personnel designated by units are subject to selection and recruitment until the last three years before being discharged from the reserves. Volunteer reservists are subject to selection and recruitment at any time until being discharged from the reserves. The recording of movements of the remainder of reserve personnel will be stopped and their military data to be sealed so as to release more manpower for national economic development and civil defense.

2. Improving the Equipment of the Reserve Forces

To better equip the mobilized personnel of all service branches, the MND promulgated in June 2001 the "Overall Planning for Equipment Preparations of Mobilized Military Troops," in which the MND listed in detail the timetables and schedules for the improvement of equipment preparations and allocated an annual budget to purchase needed equipment to upgrade military combat capabilities. All required work is scheduled to be done by 2005.

3. Improving Training for Reserve Forces

In order to maintain the professional skill of the reservists, various improvements in training were adopted in 2002 to have reservists continue training in their specialties and enhance combat capabilities. These improvements are as follows:

(1) Higher Pay for Reservists

Reservists, who are called up for training, will be paid as volunteer servicemen (about four times that of draftees) to encourage more reservists to receive training.

(2) Training Muster-call

a. Reservists, who are enlisted as “Mobilized Accordig to Actual Vancancies” and “Mobilized Beyond Actual Vacancies,” will be called up 1 time every 2 years for necessary training so as to increase the annual number this group of reservists to reach 140,000.

b. Reservists are mobilized in accordance with the degree of recovery difficulties regarding their respective MOS. Besides. They are divided according to their relevant service, using battalion as the basic muster-

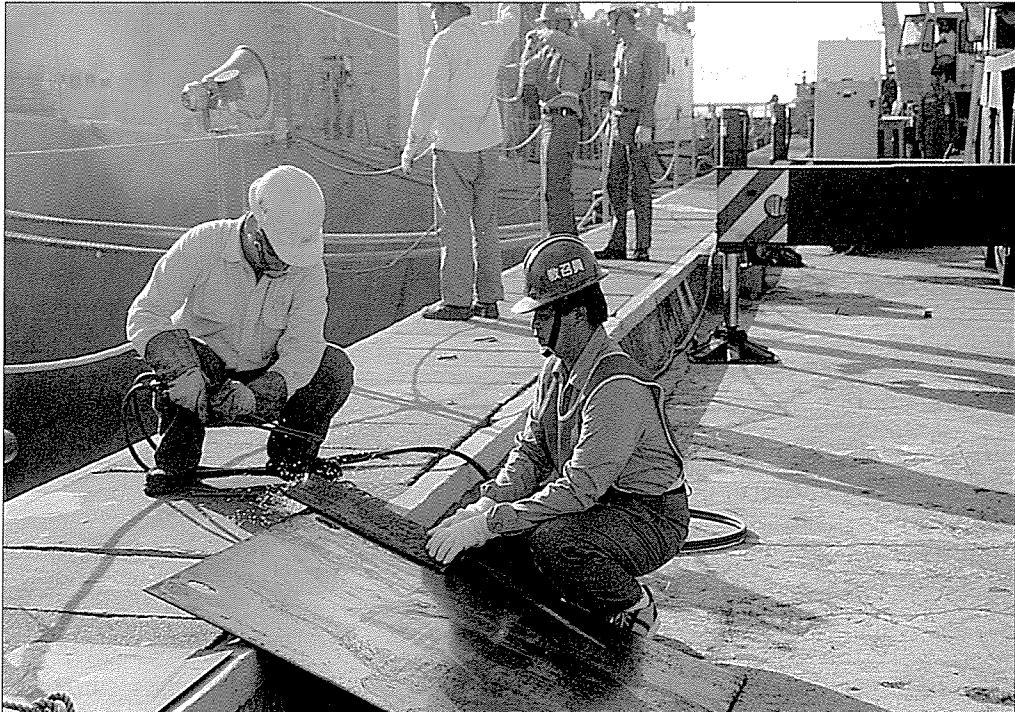

Mobilization Activity of the ROC Navy in Tzuchiang No. 19 Exercise

ing unit, and the training sessions are from 5 to 12 days.

(3) Review Muster-call

Reservists, who are enlisted as “Mobilized According to Combat Attrition,” will be called up annually for one-day (a session of 6 hours) MOS refresher courses and courses to introduce the latest weapons.

(4) Service Muster-call

Reservists, who are enlisted as “Military Service Group,” and replacement soldiers will be called up annually for assisting in military operations, and undergoing a 6 hours of training course, emphasizing assistance in military operations, such as construction and urgent repair of facilities and assistance in disasters.

IX. Vision

1. In Mobilization of Forces:

Ground reserve forces are the main body of the military mobilization. Combat theaters are where the strengths of the military and civilians are pooled. The MND improves the processes of muster-calls and conscription through “Coordination Conferences for All-out Combat Capabilities,” makes the best use of civilian capabilities and materials, and enhances reserves mobilization and readiness. This brings about a military and civilian cooperative defense and attains the goals of mobilizing local personnel for local combat mission and of immediate mobilization for fighting wars.

2. In Mobilization of Military Supply Industries:

Based on equal emphasis on both production and maintenance, the MND assesses wartime requirements, establishes production and maintenance capabilities in terms of quality and quantity, selects and organizes mobilized factories to set up a production system of military supply industry mobilization, and finishes preparations for the mobilization and produc-

tion of all military materials in peacetime. In wartime, it utilizes materials from throughout the whole country, expands the production of required military materials, and puts those materials to assist in combat missions as the first priority.

3. In Garrison Combat Mission

In accordance with Regulations for preparation of all-out defense mobilization, the MND will set up a well-defined all-out defense mechanism to organize reservists, enhance their trainings, and combine them with legally armed units to form a civil defense group under the "Civil Defense Law" so as to assure the safety in the rear areas.

4. In Organizing Disaster Prevention and Relief Units

According to "the Calamity Prevention and Rescue Law," the MND will closely combine disaster relief operations with military mobilization mechanism to adjust the scale of "Support Military Service Group" so as to assist in combat operations in wartime and disaster relief operations in peacetime.

5. In Operational Mechanism of the Coordination Conferences

In line with "the regulations for preparation of all-out defense mobilization," all the responsible governmental agencies, such as police department, fire department, administration department, etc, are integrated during Coordination Conferences for All-out Combat Capabilities hosted by Reserve Command so as to merge disaster relief efforts in peacetime with combat support missions in wartime, and establish a sound and comprehensive all-out defense mechanism.

Management of Logistics

I. Objectives and Policies

1. Objectives

- (1) To establish operational capabilities for weapons life-cycle management to make the best use of Integrated Logistics Support (ILS) functions and achieve the goal of maintaining combat readiness.
- (2) To develop a paperless environment with a corporate-type network focusing on material distribution of combined logistics and configuration management of ILS to attain the goal of precise, swift, thorough and simplified operations, enhance work efficiency, and reduce the amount of manpower and materials used.
- (3) To improve the management models for spare parts and accessories and employ modern concepts of business management to effectively improve combat readiness rates of weapon platforms, simplify operation processes, and enhance efficiency.
- (4) To increase the efficiency and insure the security of transportation and supply, upgrade service quality, and establish a modernized transportation and supply system to support combat readiness.
- (5) To make the best use of all materials through effective materials management, including building units out of and repairing with spare components, dismantling obsolete assemblies to reusable parts, as well as selling, donating, and destroying materials. To establish a clean, neat and comfortable living environment in accordance with government environmental protection policies and achieve sustainable development for the nation.
- (6) To effectively manage military barracks and make the most use of the national soil, all barracks are of fully equipped, safe and practical, comfortable, and easily maintained with comprehensive barrack plan-

ning and restructuring.

2. Policies

(1) To achieve the goals of practicality, precision, and efficiency, the MND gathers information on capabilities of entire logistics support in terms of both quality and quantity, fully utilizes civilian resources, and combines modern concepts of logistics management to achieve forward-looking, modern, rapid, thorough, and simple logistics operations.

(2) The MND is planning to set up a comprehensive information system to be used by all branches, to develop a real-time feedback mechanism for units, to refine operational processes, to properly separate supply and maintenance systems, and to utilize public and civilian telecommunication networks so as to establish a backup network for "MINET."

(3) The MND is planning and improving spare parts and accessories management, is researching a customized inventory system, accumulating reasonable quantities of inventory, and ensuring sound equipment to meet battle requirements.

(4) In the spirit of thrift, self-dependency, and serving the nation, the MND is making use of information systems to implement a proactive supply system and increase the number of outsourced companies to reduce equipment investments.

(5) To make the best use of obsolete materials, which have surplus values, they are sold to civilians, donated (or sold) to public institutions and used in education and school exhibitions. Furthermore, the MND teaches servicemen about environmental protection to encourage them to practice it, because environmental protection should be practiced by everyone at all times.

(6) Small barracks are to be integrated with large ones. Barracks in cities should be moved away from the cities. With these ideas in mind, the MND is dealing with public and civilian lands now employed by the

military as well as military lands used by non-military parties in accordance with the law to fully utilize national land resources. The MND is working on the organization and readiness of armed forces and is proceeding with comprehensive barracks planning and restructuring to enhance quality of life for servicemen while complying with laws and regulations, implementing policies professionally, and improving work efficiency.

(7) The MND is devoted to bettering servicemen's lives on offshore islands and building new quarters above ground instead of underground and after completing overall planning, it will gradually restructure defense areas in line with budget schedules.

II. Implementation Status

1. Integrated Logistics Support (ILS)

(1) Mechanism Establishment

The MND set up the Division of ILS in July 1999 to take charge of planning and developing integrated logistics among all service branches. In 2000, with the establishment of the entire system, the GHQs of each service sets up relevant departments and sections for ILS accordingly. As a result, every military weapons system will be incorporated into an integrated mechanism for support and resources management through various stages, including Planning, RDT&E, Production & Deployment, Combat Support and Phase-out, so as to advance integrated logistics.

(2) Training

The MND offers "Training Courses for Military Integrated Logistics Support" and organizes instruction tours to teach responsible officers and NCOs about integrated logistics support and increase the number of instructors teaching the subject. Accordingly, all service branches offer training programs and lectures for integrated logistics, and the National Defense Management College of the National Defense University con-

ducted classes for training instructors in teaching integrated logistics in 2001 to increase the number of teachers in the field and enhance teachers' capabilities and expertise. The "Military Integrated Logistics Support Operations Test" was held in July and August 2001 to assess the result of implementing relevant educational programs to effectively improve operational quality and capabilities of integrated logistics support. In addition, the "Annual National Defense Integrated Logistics Support Conference" was held in 2000 and 2001 to bring together industrial, public, and academic sectors to discuss relevant issues and strengthen exchange and cooperation between researchers and users to further expand and carry out integrated logistics education and training.

(3) Continuous Acquisition and Life-Cycle Support of Military Equipment

In accordance with "Regulations for the Development of the Lead-in System of Continuous Acquisition and Life-Cycle Support (CALs)," the MND guided and assisted the army and air force in finishing development of CALs lead-in systems for armored vehicles and for Tien Chien-II (Sky Sword-II) air-to-air missiles at the end of 2000. Demonstrations held at the end of February 2001, and showed the fruits of implementation. This established the basis for comprehensive CALs development.

2. Logistics Management Information Systems

(1) The information infrastructure completed for logistics management included the hardware and networks in 1,320 military nodes on Taiwan and its offshore islands, 641 training programs with 25,651 participants, 783 computer programs, and 49 publications consisting of amendments to regulations and e-books. It is expected that that more than NT\$ 411,830,000 in costs for short-distance errands and more than 14,730,000 in official signatures and stamps for paperwork will be saved within ten years. As a result, logistics preparations have become steady and logistics support

efficient. Accumulated logistics operational experience can be easily passed on.

(2) Regardless of rank and service branch, required materials can be processed through intranet application, and transported and supplied efficiently so as to greatly reduce the operational personnel required and accelerate support operations. Implementation results are to be used as reference for combat direction and decision-making.

(3) The MND set up a Bulletin Board Service in the MINET network for the exchange of ideas and increased the transparency of military affairs to reduce reaction time and help in solving problems.

3. Improvements in Spare Parts and Accessories Management

(1) The MND accumulates complete database and regulates consumption rates to make the best use of budgets and thoroughly solve supply delays. Expenditures saved are used to purchase weapons and equipment needed to ensure combat capabilities.

(2) The MND integrates logistics management information while increasing transparency in military materials so that different units can transfer extra materials to other units at the same-level that might need them.

(3) The MND is working to integrate military needs with civilian production by formulating "Regulations for R&D, Production and Maintenance by MND Technological Institutions," "Methods for Marketing and Selling Products by MND Technological Institutions," and "Regulations for the Management of MND Technological Institutions by the Private Sector" to effectively combine and upgrade domestic industries.

(4) Legal budget goals are to be adhered to, so the MND is searching for a balance between material requirements for combat readiness and financial guidelines through the strategy of "Buying Required Material En Masse, Paying in Installments" so as to avoid excess supply and inventory.

4. Materials Transportation and Supply Efficiency and Capabilities

(1) The Taiwan Food Bureau of the Council of Agriculture of the Executive Yuan and the Chinese Petroleum Corporation (CPC) are currently responsible for supplying grains, rations, and petroleum respectively to the ROC Armed Forces. As for military units in high mountains and remote areas, grain and fodder are supplied by private sector, which is authorized by responsible officers in each theater.

(2) To resolve security problems related to drummed oil, military units with oil storage tanks or which are over five kilometers from the nearest military gas distribution stations are issued CPC military oil tickets or oil cards.

(3) Main equipment assemblies, spare parts, and accessories are dispersedly stored in various locations so that military units can obtain supplies in needs from the nearest storage station.

(4) Applications for military supplies and transportation are presented on-line through the "Integrated Logistics Information System" in the MINET network to eliminate application paperwork and save manpower and time.

(5) The Taiwan Railway Administration has adopted a policy of "goods transported by their owner's carriage." Therefore, the MND prepared and implemented "Operational Regulations for Military Land Transportation" in 2001 to determine the best transportation methods, whether by railway or highway, for different circumstances to reduce dependency on railways. Military materials are now delivered by civilian freight or express mail package to alleviate burdens on troops and avoid loss during transport. Supplies used in troops training on military bases, however, are still transported by railway.

(6) In consideration of the steady development of civilian shipping companies on offshore islands, the MND has charged an increasing number of civilian companies to transport servicemen and commodities on off-

shore islands, while still maintaining basic military transportation capabilities. Restricted materials are transported by military freight, and ordinary military materials are conveyed by charter boats or by freight which charging by weight. When servicemen leave the islands, they have a variety of choices, such as charter flights, passenger ships, and other civilian transportation, to ensure high-quality transportation services and reduce equipment and maintenance costs and help develop civilian shipping companies and establish transportation mobilization capabilities in wartime.

(7) Local governments are currently responsible for the management of ports on offshore islands. The MND plans to allow legal longshoremen to assist in loading and unloading military supplies transported by merchant ships in light of the needs of defense areas to integrate local civilian manpower and material resources.

(8) Due to the fact that public transportation is becoming increasingly convenient, the MND has reduced the number of transportation vehicles for all military institutions in accordance with "Regulations for Assigning and Renting Military Institution Vehicles" to enhance efficiency of transportation to and from work and save money. In addition, it has selected institutions to carry out an experiment to rent civilian vehicles for military administrative affairs to connect national defense with the civilian sector and establish civilian combat capabilities which can be mobilized in wartime. The results of this experiment will influence further developments of this measure to reduce military investment in vehicles and use budget saved for combat readiness and capabilities establishment.

5. Materials Disposal and Environmental Protection

(1) Materials Disposal

From July 2000 to May 2002, the following weapons and equipment were phased out.

- a. Army: 16 helicopters and 1,021 tanks of various kinds.
- b. Navy: 38 vessels of various kinds.
- c. Air Force: 429 aircraft of various kinds.

Some of the obsolete weapons and equipment mentioned above were reused for other purposes. In 2001, 24 tanks and naval vessels were used for local exhibitions, 132 vehicles served as teaching materials in schools, and 5 warships were transformed into artificial reefs by the Fisheries Administration of the Council of Agriculture of the Executive Yuan.

(2) Environmental Protection

a. The MND is working on training servicemen to become experts in environmental protection. 167 servicemen have finished relevant training and obtained environmental protection certificates. In the future, the MND will continue to send personnel to participate in training courses offered by environmental protection institutions to enhance professional capabilities of servicemen in charge of environmental protection and to improve the performance of the military in environmental protection.

b. Controlling noise and subsidizing local governments

(a) To control noise in all military airbases, the MND has established monitoring facilities for all airbases used by rotor-wing aircraft of the Army and fixed-wing aircraft of the Air Force and adopted automatic noise monitoring systems. To alleviate noise impact on areas surrounding military airbases, the MND has completed construction of structures to muffle noises during engine runs in airbases in Hsinchu, Ching Chuan Kang in Taichung, Chiayi, Tainan, and Hualien and ordered all military aircraft to use farther flight paths from residential areas except in urgent combat exercises. Flight training and engine runs are not allowed deep in the night so as to effectively lessen noise.

(b) In accordance with "Regulations for Aircraft Noise Control in Areas Surrounding Airports" and "Regulations for Special Municipali-

ties and County or City Governments to Obtain Central Government Subsidies,” since 1998, the MND has begun to allocate budgets to subsidize local governments which have military airbases within their domains to improve aircraft noise control facilities and alleviate noise impact on neighboring areas, so as to improve the relationships between civilians and the military.

c. Controlling water pollution

In light of government policies for water pollution control, the MND has completed construction of more than 60 waste water processing stations in military hospitals, factories, ports and logistics maintenance agencies to protect domestic natural waters and ensure cleanness of water resources.

d. Reducing garbage and recycling

To reduce garbage and promote recycling in military barracks, the MND and the Environmental Protection Administration (EPA) cooperated and developed the “Project for Recycling in Military Institutions” in 2000 to educate servicemen how to do recycling processes in their units. In the future, the MND will continue to promote recycling in all military barracks and further integrate surrounding communities into its recycling system to encourage more people participate in recycling.

6. Military Land Management

(1) Utilizing Military Realty Management Information System

With the implementation of the “Combined Logistics Program,” all regional managements in charge of military real estate were integrated with the Military Real Estate Construction Administration of the Combined Logistics Command. Military real estate data now can only be acquired, modified, or deleted through the “Military Realty Management Information System” in the MINET network to reduce human errors and improve operational efficiency.

(2) Handling Issues of Public and Civilian Lands Used by the Military and Military Lands Used by Non-Military Parties

In consideration of military deployment and refining policies after the implementation of the "the ROC Armed Forces Refining Program," the MND has checked and dealt with public and civilian lands now employed by the military as well as military lands used by non-military parties in accordance with their very situation and the law. In 2000 and 2001, the MND returned 154 hectares of public and civilian lands now of no military needs and purchased, drafted, and acquired 388 hectares which still are of military importance. 53 hectares of military lands used by civilians were retrieved with 28.4 hectares transferred to the National Property Bureau.

To protect the rights of inhabitants living in Kinmen and Matsu area, Paragraph 1 of Article 14 of the "Kinmen and Matsu Pacification Regulations" stipulates that Kinmen and Matsu inhabitants may apply in a group for lands with relevant documents such as land certificates and testimony of neighbors. Based on its obligation and the protection of rights and interests of the nation, the military may apply for lands in accordance with the "Kinmen and Matsu Pacification Regulations" and Article 52 of the "Land Law" so that both the military and civilians can obtain their respective legal rights.

(3) Dealing with Lands not in Use

To alleviate burdens of managing and guarding barracks on basic troops, the MND is planning to finish in three phases checking and dealing with barracks now no longer in usage before the end of 2002. Listed barracks which are not in use and not designated to use will be returned or become non-public property and then be transferred to the National Property Bureau.

To satisfy the needs for political and economic construction and fully utilize national land resources, 173 hectares of 93 barracks were offered

accordingly in 2000 and 2001. Barrack Shenyang in Taipei became part of the Tanshui New Town. Barrack Changshu Bay in Taipei was transformed into a switchyard for high-speed rail service. Barrack Huwei in Yunlin is now employed by the National Taiwan University. The Taoyuan Tank Training Field was used for widening the West Coast Highway. Barrack Tuhsing in Hsinchu was allotted to the Science Park for the third phase of expansion. The Fengnien Airport in Taitung was reused by the Civil Aeronautics Administration for establishing a radar station. Barrack Chingwu in Kaohsiung was used for the development of the Kaohsiung New Town, and the Pintung Basic Military Training Center (BMTC) for the establishment of the Tapeng Bay Scenic Area. Currently, The Ilan Airport is being transferred to the National Tsing Hua University for school expansion.

7. Enhancing Construction Quality

(1) Cooperating with Private Sector to Join Construction Works

To speed up restructuring old barracks and improve quality of life for all servicemen, the MND is restructuring all barracks with comprehensive planning to attain the goal of fully-equipped, safe, comfortable, and easily maintained new barracks. The MND will continue to authorize architects from private sectors to plan and design and will supervise the construction work to integrate civilian manpower and resources into national defense construction.

Military construction will be carried out in accordance with the "Government Procurement Law" and relevant laws and regulations. The MND will authorize civilian companies to undertake military construction in an open, fair, and impartial manner to attract more professional architects and combine civilian experiences and expertise to further enhance quality of military construction.

(2) Improving the Living Environment for Servicemen on Offshore Is-

lands

In accordance with land redistribution operations in Kinmen and Matsu area, the MND is gradually restructuring defense areas now legally owned by the military to improve quality of life for servicemen on offshore islands. The first phase including the restructuring of ten places in Kinmen such as Barrack Tunghsiao and four places in Matsu such as Barrack Hsia Chih Ching was completed in 2000. These second-line bases are now in use. The second phase started in 2002. The MND continued to restructure Barrack Tungchou and Barrack Shanhou in Kinmen, and Barrack Huchu in Tungyin. The work is expected be finished in 2003.

(3) Enhancing Professional Capabilities of Military Engineering Personnel

The Chinese Army Engineering School began to conduct classes for training quality control engineers in 2001 with the approval of the Public Construction Commission of the Executive Yuan to establish a system for training military engineering personnel and assisting them in obtaining national professional certificates. Trainees include managers, undertakers and supervisors in charge of military engineering affairs from three service branches. In 2002, the training classes were integrated into the formal military educational system to effectively strengthen the morale of engineering personnel.

To continue to enhance professional capabilities of military engineering staff, the Chinese Army Engineering School has started to offer engineering management courses since 2000. Four times a year, courses focus on construction and maintenance engineering affairs, including laws and regulations, engineering appraisal, work supervision and construction management to strengthen servicemen's operational capabilities of engineering practices.

(4) Increasing Military Engineering Manpower

With cutting military engineering manpower, the military buildings and facilities maintenance system altered from a five-level system to a two-

level system with area-level planned renovation and unit-level regular maintenance to simplify engineering operations and enhance efficiency. To attain the goal of sharing resources and devolution of power and duties, every area is to be in charge of annual renovation construction of buildings and facilities, including design, planning, public bidding, and work supervision to make the best use of human resources.

(5) Checking and renovating dangerous facilities

The MND began to comprehensively check, list, and manage dangerous facilities in 1999. Facilities, which would cause immediate danger, were improved in the year. Those representing potential danger were renovated in 2000 and 2001 with budget allocated to facilities maintenance. Due to frequent typhoons and torrential downpour, the MND devoted itself to facilities renovation in 2001 and 2002 and promulgated "Regulations for Managing Water and Soil Conservation Facilities for Construction in Barracks and Bases of the MND and Its Affiliated Agencies." Personnel were sent to regularly patrol barracks and check facilities to carry on enhancing security and prevent disasters.

III. Vision

1. To enhance logistic management mechanism, distinguish the authorities between the establishing and using of forces, incorporate modern corporate concepts so as to establish modernized logistic management environment for the ROC Armed Forces, effectively utilize limited resources, and provide timely and appropriate support to combat missions.

2. To dedicate to ILS system, doctrine development, training & education, restructuring of operational process, standardization of documents, CALS system so as to effectively decrease life-cycle cost of weapon equipments, and enhance overall efficiency of ILS.

3. To utilize technologies and human resources from private sector, promote commercial maintenance for military equipments via strategic alliance

with corporates so as to save costs in military investment, and make the best use of manpower.

Management of Forces

I. Objectives

Regarding the management of forces, the MND has focused its attention on adopting scientific, humanistic, and reasonable methods to manage the ROC Armed Forces, especially in aspects like military internal security, training safety, and discipline realms, so as to effectively perform organizational functions, and increase overall combat strength of the ROC Armed Forces.

II. Implementation Status

1. Internal Management

(1) Concrete Measures

Internal Management is a modern scientific method used by cadres to properly manage the personnel, affairs, time, places and material resources in the ROC Armed Forces, and efficiently schedule, control and make use of the time. Internal management includes all of the internal affairs in the ROC Armed Forces, starting from combat, training, logistics, discipline to food, clothes, housing, transportation, education and recreation, etc. The management methods contain On-site Management (management by actual presence), humanized management, problem focus management, precautionary management and administrative management, etc. The principles of management emphasize on scientific attitude and methods, a comprehensive system and correct data information. Thus, as for servicemen, the management should include all personnel across the ROC Armed Forces communities. After receiving relevant training and assessment, trainees can thus make best use of their specialties and therefore enhance the performance of whole organization. As for military affairs, everything should be handled

properly. For example, all military affairs, such as daily life, combat training and military discipline, should be applied and managed properly. As for the time management, since time is limited, in order to make the best use of time, characteristics of servicemen, military affairs, time, places, and materials and the priority order of units should be well evaluated. As for places, military units should send designate specific servicemen to maintain respective areas of duty so as to ensure the force security. As for material resources, in order to make the best use of material resources, the account books should be set up efficiently, inventory should be checked regularly, and all the weapons, equipments and other papers should be maintained properly.

(2) Measures for Gender Equity

On the basis of "Gender Equity," the MND has already developed a policy to protect female servicemen's security, promotion, education and management. As for various rights and welfare, female servicemen will be treated as male servicemen, according to the "Same Service yields Same Pay" spirit, so as to create a harmonious and equally treated environment for all servicemen.

The MND has enacted the "Regulations for Management of Female Servicemen" and the "Management, Discipline and Demerit Regulations for Relationship between Both Genders" to establish a modern, rational force management system with the anticipation of a fair and safe environment in which females are free from sexual harassment. Furthermore, it is requested that various units of the ROC Armed Forces should take their physical characteristics into consideration while employing female officers and NCOs. The daily life requirements and service demands should be rational on the basis of equity and the avoidance of discrimination or inequity. In order to let the female officers and NCOs serve without misgivings in their units, the MND not only established facilities for daily life usage, but also hold regularly "Meeting for Female Ser-

vicemen Regarding Life and Duty” to review its implementation of the policy, improve settings for such mechanism so as to create a secure and comfortable environment, and eventually accomplish the goal of implementing a humanized management.

(3) Leaves for Servicemen

Along with the enactment of “Policy of Two-day Weekends for Government Employees” by Executive Yuan and Examination Yuan, the MND has also enacted “Policy of Two-day Weekends for Servicemen” on a fair and reasonable basis to stimulate the working efficiency and boost the military morale. However, the new policy cannot either violate related regulations for combat readiness or lower the training standard. It is requested that servicemen should have as many holiday as government employees do. However, the demands on tasks and characteristics are varied from unit to unit, servicemen sometimes have to take turn or postpone their legal leaves.

2. Training Management

According to the concepts of military strategies, military trainings are conducted in coordination with the annual polices. The military training courses are designed in accordance with the tasks and characteristics required in every unit, and accommodated to a series of basic, coordinated and combined training procedures. By sticking at the core principle of “All-around Combat Readiness Missions,” the military trainings aims to achieve the goal of “Trained for Combat.” The training goals, courses, key points, subjects and required training hours in every phase are designed on the basis of “Precise and Practical.” Besides, according to combat mission requirements in different levels, training standards will be different accordingly so as to reach the goal of “Combination of Combat and Training.”

(1) Training Concepts

All units in the ROC Armed Forces should strictly abide by the training



Test of Individual Physical Conditions and Combat Skills

system (plan, implement, supervise, examine and evaluate) on the principle of "Authorities Corresponding to Responsibilities." The training tasks, which are assigned in all units, should focus on the training goals of "Basic Military Training," "Specialized Military Training," "Post Preservation Training," "Post Routing Training," "Base Training," "Combat Task Training" and "the ROC Armed Force Joint Combat Exercise." While drawing up the training plans, the authorities concerned should put the differences in training objects, time, environments, characters and ways of implementation into consideration, thus to substantially enhance the implementation results so as to build up the overall defense capability.

(2) Training Policies

a. Fundamental Training: New conscripts have to undergo "Basic Military Training," "Specialized Military Training" and "Training for Specific Service Branch," etc., in order to establish the fundamental combat capabilities of the ROC Armed Forces.

(a) Basic Military Training: In order to transform new conscripts into well-trained servicemen, basic military training courses, which started with "Orientation Training," will adopt a progressive way to instill

martial law, individual combat skill, basic rifle shooting practices and to strengthen their physical status via standardized instruments and procedures. New conscripts are expected to become “qualified combat servicemen” after finishing these trainings.

(b) Specialized Military Training: On the principle of “Supervision Units Offer Trainings and Units Responsible for Deployment,” training for each “Military Occupational Specialty” is conducted by relevant supervision units in order to make new conscripts obtain eligible certificates to operate combat equipment and weapons, and meet the demands of the transformation of “Qualified Combatants.”

b. Post Training: The focus of Post Preparation Training before Base Training and Post Preservation Training after Base Training is placed on mastering the relevant MOS in all units and completion of joint training. By continuously receiving MOS training, routing training and achievements evaluation in this regard, the goal of the preservation of “basic combat readiness” can be maintained.

(a) Post Preservation Training: All responsible units should set up a formalized schedule to carry out the Task Control on a monthly or quarterly basis. The emphasis of post preservation training is put on specialty review training, individual unit combination training and combined units integrated training. Also, the training should carry out everyday except for legal leaves, education day, logistic operation day and officer- in-charge’s day. Furthermore, in compliance with specialties of respective branches of the ROC Armed Forces, the emphasis of the training courses is mainly on joint training, with subsidiary training in MOS training.

(b) Post Routing Training: The courses of post routing training, which must be completed within 3 months, focus on mastering specialties in units of all levels and aiming at achieving the goal of “Accomplishing Joint Training.”

c. Base Training: Base training is not only the focus of military combat training, but also an important means to enhance the combat strength and maintain combat readiness. The emphasis of base training, which should be completed within 3 months per training period, is mainly placed on advanced joint training for equipment, tactics, command and staff procedures and combined arms activities. Besides, application of simulators can also be incorporated to certify advanced training certificates. The objective of base training is to establish “Basic Combat Capability of the Each Arms.” Thus, under the surveillance of instructors and units in charge of the training exercises, servicement, who received relevant training, are required to accomplish a series of well-organized and integrated training courses in a certain limit of time.

d. Combat Readiness Training: By carrying out the current deployment and defense combat plans, the combat readiness training aims to testify and verify the combat capabilities at each theater (Naval Fleet Com-



Joint Operational Training of the ROC Armed Forces

mand and Air Combat Command) so as to facilitate command & control, intelligence integration, combat control, logistic support, communication, battle activities. Besides, it also reviews adoptabilities and availabilities of plans of deployment and operations so as to find out drawbacks, manage out refining measures and complete the combat readiness task of the ROC Armed Forces.

e. Joint Combat Exercise: In concert with post training, base training and combat readiness exercises, Joint Combat Exercise should be carried out in 4 stages, including Basic, Combined, Unified and Armed Forces Joint exercises. Furthermore, by establishing a well-organized system of CI⁴SR and the integration of three-dimensional combat capability, Joint Combat Exercise should put the demands for different defense combat missions into consideration and carry out joint (combined) operations or defense strategies in Navy-Air Force, Army-Air Force, and Army-Navy to exert esprit de corps, and develop an integrated combat capability of the ROC Armed Forces.

f. Night Combat Training: By synchronizing with the phases of various kinds of unit training and integrating new conscripts, post and base trainings together, each GHQs should focus on courses in mobilization, night combat capability and weapon firing training according to various tasks and characteristics of each service.

g. Training Resources: In order to maximize the utility of training resources and give trainings a fully support, the MND will properly allot the training resources annually on the basis of "Serve Actively from Top to Bottom, and Satisfy Basic Units."

(a) Training Expenses: GHQs of each service should consider the characteristics of its subordinate units, and draw up detailed budget plans accordingly. In order to fully support the basic units and effectively implementing training programs, the expenses of each training course in basic units are budgeted on the basis of "Implementation After Budget Granted."

(b) Training Grounds: Common training grounds for the ROC Armed Forces are planning to be established to fulfill the goal of “comparability, “standardization,” “Unification,” and “Modernization” in each theater. Factors such as station tasks, characteristics and efficiency of organic weapon, local development and environment protection are also considered. Accordingly, there training grounds are developed as medium or large scale Versatile Training Ground, Naval Training Ground or Aerial Training Range so as to effectively assist in unit training.

(c) Training Simulators: Due to concerns over insufficient training grounds, time-saving, equipment attrition and training efficiency, units, which operate simulators, should carefully calculate the training attrition, strictly organize budgetary plans for them while purchasing new training platforms, dispatch specific unit to be responsible for their maintenance and supply, and incorporate them in the “Logistical Maintenance Supply Support System.”

(d) Training Doctrines: the MND has been working hard to elevate the quality, depth and quantity of the training doctrines, lays emphasis on the development of new generation of the ROC Armed Forces, and will finish revisions on relevant doctrines according to designated schedule.

h. Training Disciplines:

(a) Training Safety: Training for Hazard Prevention guarantees training safety. Military units at any levels should have a understanding of “Protection of Human Life Is Utmost Important; Safety Is the First Priority,” so as to implement a strict discipline of “Hazard Prevention, “ create a system of “Authority Corresponding with Responsibility,” and adopt measures of “Safety Rules First, Orders Afterwards.” Every units must do their best to prevent accidents, and to accomplish the safety objective of “Zero Casualties, Zero Accidents.”

(b) Rewards and Punishments: The rewards and disciplines of trainings are set up on the basis of “Swift Process of High Reward

and Strict Punishments.” As for promotion points, units executing combat duties will be granted first. The rewarding level of administrative units cannot exceed that of combat units so as to make basic units focus on combat trainings. Officers with high performance will be promoted first; however, officers, who is below training standard or position criteria, will be replaced or submitted to punishments. The training results will be adopted as a important consideration for performance evaluation and promotion.

3. Military Safety Disciplines Management

(1) Implementing Precautions

Due to the fact that more and more servicemen violated the traffic regulations and were killed or wounded after the implementation of two-day weekends, the MND developed “Concrete Steps for the Prevention of Casualties and Discipline Violation,” which put the emphasis on law and discipline education, internal management, unit training, safety discipline, and traffic education with the prospect of “zero casualty.”

To enforce the precaution of casualty, since 2000, the MND also formulated the rating system for “Prevention of Casualties Outside the Barracks and Self-infliction,” to reduce the possibilities of accidents by swift rewarding. Meanwhile, the MND requested officers at superior levels to care for their subordinate servicemen’s daily life, contact their families more often, put more emphasis on psychological consultation, and strictly inspect the internal management. Cadres at all levels must bear in mind that “A person injured, a family harmed,” “A soldier broken the laws, an army shamed.” Besides, by administering “military safety discipline spot-check” and “carrying out orders,” the commanders must urge units at all levels not only think highly of psychological consultation and precautions, but also stress the importance of security measures so as to prevent necessary casualties.

(2) Strengthen Function of Supervision

In year 2001, the MND had set up "Advanced Courses for Supervisors," which prolonged the length of supervisors' basic training to 4 months in order to sharpen their knowledge so as to attain the goal to be qualified as supervisors at brigade level. Moreover, the MND also set up "Supervision Section" in the Fu Hsing Kang College's research class to establish a well-organized education system of supervisor training, and recruit professional supervisors annually so as to foster more outstanding supervisors in this regard.

In order to prevent embezzlement, perform the functions of supervision institutions and maintain excellent reputation of the ROC Armed Forces, the MND had supervised 36,000 procurement cases and the total amount of expenditures reach NT\$ 100 billion. Furthermore, 6,100 servicemen had reported their properties in conformity with the "Sunshine Policy." Besides, under the program of "Prevention of Embezzlement and Practice Reform," the MND will dispatch a task force to supervise units of all levels. Poorly performed units will subject to severe punishment so as to establish recognition among servicemen to abide by the law and prevent any illegal activities.

(3) Psychological Consultation Mechanism

The purpose of psychological consultation is to relieve the pressure and emotion of servicemen for making them adapt to the military environment. Substantial efforts are classified as three categories:

- a. Prevention Stage: conducted by political warfare officers in the company level.
- b. Outbreak stage: the MND has set up "Psychological Consultation Center" above combined arms brigade level in the Army, wing level in the Air Force and fleet level in the Navy. Patients transferred from company level units and recorded by "Physical and Mental Evaluation Chart," will be dealt with by professional consultants.

c. Medical Treatment Stage: "Area Psychological Consultation Centers" were set up island wide and in Penghu, Kinmen and Matsu areas. These centers employ specialists in the civilian sector as their counselors. If patients having no obvious improvements will be transferred to these center for further treatments. Furthermore, these centers combine with resources from local hospitals to provide crisis management, intensive consultation so as to rebuilt a healthy mentality among those patients. In 2000 and 2001, 136,165 sick-call servicemen have received psychological consultation, 54,844 psychological consulting seminars were held, and 640,173 servicemen were assisted to relieve pressure, which shows substantial results.

In order to keep up with the fast development of Internet in today's society, and effectively promote the interaction and experience exchanges between servicemen and counselors, the MND had built a "MND Psychological Consulting Center website" (pgs@mnd.gov.tw) in December 2000. This website provides information and services to servicemen and its dependents so as to help them quickly solve their problems.

To enhance the perception of psychological consultation among servicemen, courses of psychological consultation have been incorporated into academies' curriculums as a required subject. Courses in "Pressure Adjustment," "Emotion Management," "Life Planning," "Prevention of Self-infliction," "Human Relationships," and "Gender Relationship" also have been incorporated into new conscript courses in BMTC. Psychological consultation centers in the company and battalion level hold various seminars annually, and invite scholars and specialists to give lectures on the subject of psychological consultation.

(4) Unobstructed Channel for Complaints and Appeals

To protect the legal rights and privileges among servicemen, and to promote unity in the units, in 1998, all units of the ROC Armed Forces set up "0800"- toll free call to handle properly the complaints and grievances filed

by servicemen. (As Table 5-5) The objective of these measures is to immediately handle complaints, grievances, accusation and legal rights among servicemen, thus promote the unity of the Armed Forces. 3,450 cases of complaints and grievances had been handled in 2001, and most of cadres were devoted to solve problems and discover potential danger of any kinds.

(5) Prevention of the Leakage of Military Secrets

To instruct servicemen how to clarify enemy's conspiracies and enhance awareness of security in line with the actual conditions in the forces. Based on the concept of "administration by law," to perform authentic supervision over military personnel, and impose heavy penalties on incidents of possible leakage of military secrets so as to prevent such incidents from happening, and maintain the security in the ROC Armed Forces

III. Vision

1. Internal Management

The MND will continuously follow the policy of "According to Respective Position and Regulations," fairly, reasonably and efficiently conduct management of personnel and materials so as to establish a modernized, humanized, and reasonable unit management. Accordingly, every serviceman has one's respective responsibility to cope with, every matter has its way to follow, and every item has its location to stand. As for those inadequate regulations, they will be reasonably amended to form a concrete basis for servicemen to follow so as to make them effectively conduct combat missions.

2. Training Management

In order to implement the strategic guidance of "effective deterrence, resolute defense," the MND will continually foster a new generation of high-tech force and revise the current strategies and tactics to keep up with diversified changes posed by the enemy in this regard. Furthermore, the

Table 5-5
The List of "0800" Toll Free Numbers of the MND and Various Units for Consulting and Appealing

Unit	Phone No.	Unit	Phone No.
The MND	0800-534785 0800-534885	Command, Marine Corps	0800-756013
The National Defense University	0800-025566	Naval Academy	0800-756999
The Chung-Cheng Institute of Science & Technology	0800-311996	Navy Technology School	0800-095951
The National Defense Medical college	0800-017111	The School of Marine Corps Force	0800-018589
The National Defense Management College	0800-008221	General Headquarters, Air Force	0800-081400
Fu Hsing Kang College	0800-291216	Air Combat Command of the Air Force	0800-028052
General Headquarters, Army	0800-060070 0800-321454	Logistics Command of the Air Force	0800-094580
The Military Academy, Army	0800-008997	Anti-Aircraft Artillery & Garrison Command	0800-023253
The NCOs School, Army	0800-070895	Air Force Academy	0800-007072
The Chemical School, Army	0800-079795	Air Force Aviation and Technology School	0800-009585
The Communications, Electronics and Information School, Army	0800-099012	Combined Logistics Command	0800-251090
The Logistics School, Army	0800-090212	The 202nd Arsenal of Combined Logistics	0800-027885
The Engineer School, Army	0800-099010	The 203rd Arsenal of Combined Logistics	0800-060011
The Sixth Army Corps	0800-090752	The 204th Arsenal of Combined Logistics	0800-012555
The Eighth Army Corps	0800-008095	The 205th Arsenal of Combined Logistics	0800-090109
The Tenth Army Corps	0800-015995	Reserve Command	0800-077775
Kinmen Defense Command	0800-023600	Taipei Division Command	0800-090909
Matsu Defense Command	0800-085945	Taichung Division Command	0800-007885
Penghu Defense Command	0800-099500	Tainan Division Command	0800-090101
Hualian Defense Command	800-381020	Military Police Command	0800-221507
General Headquarters, Navy	0800-221760	Military Police Academy	0800-000580
Fleet Command	0800-035835	Military Police Training Center	0800-090093
Naval Logistics Command	0800-756010		

MND will fully strengthen the training effects and accomplish the demands of “combine fighting with training” by performing combat tasks training or the ROC Armed Forces Joint Defense Combat Exercises.

3. Military Security and Discipline Management

The MND will continuously promote the proposals to increase organic manpower, sharpen servicemen’s MOS, and legalize every process regarding national defense. Major concerns in this regard as follows:

- (1) Raise the average ratio between servicemen and consultants. It is expected that the said ratio will increase from 1:1,600 to 1:1000 by recruiting more psychological consulting officers and consultants.
- (2) Assist psychological consulting officers and consultants to get their legal certificates, and promote their professional skills and consultation works.
- (3) Offer major consultation courses to servicemen annually. The context within these courses will also be incorporated in the Political Education Program broadcasting in TV so as to establish a positive consultation recognition and prevent incidents, like emotion-off-balance and self-infliction, from happening among servicemen.
- (4) Develop a “Mental Condition Evaluation Mechanism for Servicemen,” in which creates a checklist, including items like “Human Relationships,” “Thought,” “Emotions,” “Behavior,” etc., so as to find out personnel with mental problems or diseases.
- (5) Build “Database of Individual Psychological Consultation Cases of the ROC Armed Forces,” make the most of “Computer Statistics System for Military Psychological Consultation Tests,” and effectively assist consultants at all levels and promote the information system of consultation work.
- (6) Set up a mature system of fostering supervision cadres to realize the policy of “Administration executed by law,” “Eradication of Corruption,” and “Setting Upright Character of Servicemen.”

Management of Communications & Electronic Information

I. Objectives and Policies

Under the guideline of “effective deterrence, resolute defense” and the requirement of joint operations, the communication and electronic information capabilities of the ROC Armed Forces are fully developed and integrated so as to obtain superiority in this regard, consolidate national defense, and achieve preemption over aggressors. Furthermore, based on the concepts to combine peacetime and wartime activities, such capabilities will be prioritized and planned in detail so as to create their future development strategies. Currently, major policies in this regard are as follows: (1) Integrate C⁴ISR system to strengthen battlefield C² capabilities, (2) Enhance defense information infrastructure and increase Minet’s efficiency and systems’ survivability, (3) Strive for a better communication and electronic warfare superiorities and establish capabilities to maintain information security of the ROC Armed Forces as well as capability to counter hostile cyberstrike, (4) Integrate efficiently communications and electronic information system so as to make the most of the military network resources, (5) Realize digitization processes of the ROC Armed Forces activities, establish a common information platform to share information among different service branches, and (6) Promote “Outsource” policy in order to effectively utilize human resources from private sectors and create a potential domestic manpower market.

II. The Emphasis and Implementation Status

According to the guidance for the planning and development of communications, information, and electronic warfare of the ROC Armed

forces, major concerns in this regard and the relevant implementation results are as follows:

1. The Integration of C⁴ISR

In the light of creating a concrete and unified capability of the new generation force, the ROC Armed Forces is working hard to establish an automatic data link to connect C⁴ISR system and the relevant systems in the three branches of the ROC Armed Forces. Such datalink will combine major C² systems and weapon platforms, enable real-time synchronization of information exchanges among combat units so as to construct a real-time decision-making assistance mechanism and increase battlefield control, efficiency of decision making, and overall combat capabilities of the ROC Armed Forces.

2. The Development of Defense Information Infrastructure

In keeping with the implementation of National Information Infrastructure (NII), the MND devotes every effort to implement the development of fundamental defense information infrastructure. The establishment of "Mainframe Information Transmission Network of the Armed Forces" and "Information Network Connected Transmission Centers and Clients" is the main task in this regard. These networks will manipulate the connection among information transmission centers, combat intelligence C² centers, military bases, barracks and factories so as to provide the Armed Forces with reliable information transmission and exchange regarding battle intelligence, C², personnel, logistics and finance. Based on mission requirements, the MND will increase gradually the number of information transmission center and expand the bandwidth of the mainframe network. Furthermore, data network of private Internet Service Providers (ISP) will be adopted to set up a backup system for MINET so as to enhance the efficiency of the military network and survivalability in battlefield.

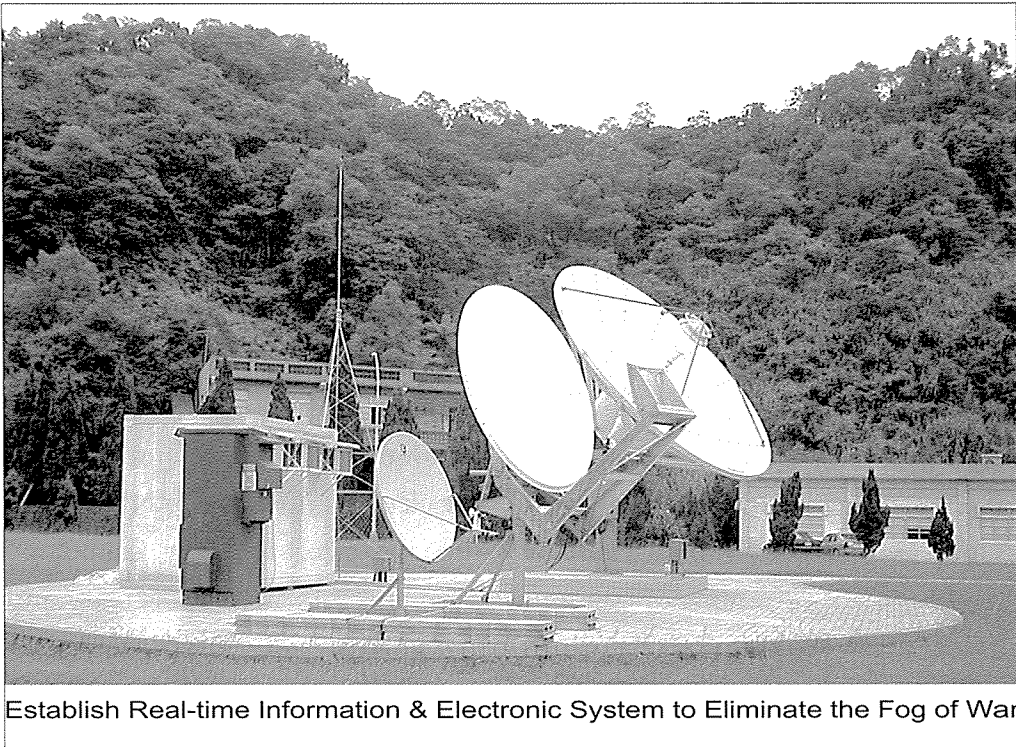

3. Strengthening the Capability of Electronics Warfare

Facing future combat situations and joint combat requirement, the MND has carried out the preparation for electronics warfare readiness. Besides, according to the "Guidance for Preparation of Electronics Warfare Readiness of the ROC Armed Forces," the MND has established a concrete offensive and defensive electronic warfare capability. Currently, these efforts have begun to bear fruits. Air Early Warning (AEW) fleet has been commissioned and the capabilities of offshore radar sites have also been strengthened. Furthermore, the establishment of the "Automatic Management System of Spectrum Database of the ROC Armed Forces" is in full swing so as to effectively manage spectrum resources, assure communication discipline, secure the information transmission and substantially

strengthen the overall electronic warfare capabilities of the ROC Armed Forces.

4. Establishing a Superior Information Warfare Capability

The objective of information warfare is to ensure the "Security of Communication, Information and Network of the National Defense." Under the guideline of "Defense first, Swift Responses & Preemption," the MND has adopted the strategy of "Active Surveillance & Reconnaissance, and Protection" to establish a security protection capability of communication and information, which stresses "Early Warning and Quick Response" so as to maintain superiority in communication and information. Furthermore, in order to cope with cybervirus warfare, the MND has established an information warfare task force in concert with key technology development programs of communication and information security and "Net Safety Program" of the CSIST so as to create relevant technologies regarding cybervirus control and prevention.

5. Effectively Integrating Communications and Information Network

In order to fulfill future combat mission requirements, the MND has integrated Radio Frequency (RF) resources, in keeping with the establishment of new generation communication and information equipments, to annex excess RF systems, so as to fully interate every platform and system in this regard and fulfill the joint combat requirements if the ROC Armed Forces.

6. Realizing Digitization of Activities of the ROC Armed Forces

In line with the policy of Executive Yuan and farflung technology development as well as integration of information technology and communication network, there are 11 programs in this regard underway, like "Document Exchange System Among the MND, Executive Yuan And Their Subordinate Units." Once the projects are completed, defense activities can be

greatly simplified and efficiently handled, and servicemen can utilize computer to access or process their relevant tasks no matter one's whereabouts.

7. Promoting Outsourcing Policy

The MND are promoting non-nucleus information activities to be undertaken by outsource contractors according to the "Regulations for Outsource Activities Concerning Information Service of Executive Yuan and its Subordinate Agencies." Furthermore, in keeping with downsizing and transformation of the communication, information and electronic warfare task force, the MND now is considering revisions regarding its "Outsource" policy so as to effectively utilize human resources and help create more job opportunities.

III. Vision

In the light of integration of C⁴ISR, the MND is slated to establish a "Joint Datalink of the Armed Forces aims" to combine major weapon systems and C² systems with fiber-optic network around the Taiwan Proper so as to have transparency in battlefield information, share real-time intelligence and automatize decision making process. Besides, relevant communication and information resources in private sector will be effectively incorporated with military systems in order to form multiple nodes between military and civilian organizations and a mutual assistance communication system via this type of duplex network so as to effectively strengthen the overall combat readiness of the ROC Armed Forces.

As for how to attain superiority in information and electronic warfare, the MND, under the guideline of "establishment of capable electro-magnetic shield," "integration of intelligence," "protection first," and "swift reaction and preemption," will adopt measures, like "joint surveillance and reconnaissance," "early warning" and "combination of offense and defense," to establish strong preemption and counterstrike capabilities of informa-

tion and electronic warfare, uphold superiority in this regard, dominate the battlefield, and create a positive strategic posture for the ROC Armed Forces.

In the aspect of integration of communications and information networks of the ROC Armed Forces, the MND, aside from the establishment of common RF equipments, promotes the process of "Simplification of General Switchboard Code and Corresponding Router of the ROC Armed Forces" so as to create a automatic exchange network to combine switches in each service of the ROC Armed forces and those dispersed in different theater. Furthermore, the said system will be equipped with multiple router system to enhance the liability and accessibility of networks.

In the future, the reconstruction of communications & information system in the ROC Armed Forces will focus on supporting the joint combat command mechanism, establishing C⁴ISR system, and integrating communications & information networks so as to improve the battlefield management.

PART SIX |
IMPORTANT NATIONAL DEFENSE
POLICY IMPLEMENTATION |

Summary

1. Pursuant to the Constitution and the National Defense Law, the ROC Armed Forces contributes its loyalty to the nation and all its strength to safeguard the people and maintain national security. All servicemen steadfastly uphold the belief of “to fight for the survival and development of the Republic of China” and “to fight for the security and welfare of the people of the Republic of China.”
2. To implement the National Defense Law and Organization Law of the Ministry of National Defense, the MND has established the “Organization Planning Committee” subordinated with various planning operation groups. The task of reengineering the defense organization will be undertaken in three stages: the planning, restructuring the organization, and finalizing and putting the restructured organization into operation. The Executive Yuan has approved and promulgated the above-mentioned two laws to be effective from March 1, 2002. In accordance with these two laws, the MND will restructure all its subordinate branches and departments in order to create an institutionalized defense organization.
3. Abiding by the educational laws and regulations, the ROC Armed Force will establish a new military education system and actively promote life-long learning, in order to cultivate technically capable and professional military cadres so as to face future challenges.
4. During 2001 and 2002, the ROC Armed Forces have conducted more than 150 exercises and training in the four fields like operation, mobilization, nuclear & chemistry, and training. All the exercises and training have been completed according to the specified instructions and timetables.
5. The two sides across the Taiwan Strait should establish a mechanism for mutual trust based on the principles of “showing friendliness,” “no designated levels,” “no presumptions,” and “mutual respect.”
6. Following the spirit of autonomy and independence, the ROC Armed Forces has retained key technological know-how to indigenously develop various counter-measure weapon systems to conduct counter-air and

counter-sea, and land defense missions so as to strengthen its overall combat capability. In line with national economic development, the ROC Armed Forces is also promoting the concept of develop dual-use technologies between military and civilians so as to enhance R&D capabilities in the private sector, and further elevate national competitiveness in world stage.

7. Servicemen are also citizens of the nation, and therefore are entitled to basic human rights as defined by the ROC Constitution. As such, the MND has set up a complaint mechanism for servicemen, established the Commission for the Protection of Servicemen's Legal Rights, and revised the Criminal Law for the Army, Navy and Air Force, in a bid to realize the protection of servicemen's human rights.
8. In order to carry out the President's "three assurances policy," aimed at guaranteeing safety for the forces, giving servicemen a steady life, and providing military dependents with better living standards, the MND has been working hard to realize well-round welfare services for military personnel so as to make them focus attention on their duties and retain their respect to be upright soldiers.
9. The ultimate goal of rebuilding military dependent quarters is to create a "win-win-win" situation for the government, the public, and military dependents, contributing to increasing tax income for local governments, reviving the overall economy, and creating job opportunities.

Chapter 1

Position and Mission of the ROC Armed Forces

I. Nationalization of the ROC Armed Forces

Article 138 of the Constitution of the ROC stipulates, “the Army, the Navy, and the Air Force of the ROC shall be above personal, regional, or party affiliations, shall be loyal to the nation and shall protect the people.” Clause 1 of Article 6 of the National Defense Law stipulates, “The ROC Armed Forces shall remain legally neutral from personal, regional, or party affiliations.” The ROC Armed Forces abides by the Constitution and the National Defense Law, and its nature is a nationalized force, which belongs to the people. Every undertaking of the ROC Armed Forces shall follow the Constitution national regulations, democratic norms, legal system, and neutrality so as to realize the nationalization of the ROC Armed Forces.



Loyalty, Unity and Best Performance in Military Duties

II. The Position and Mission of the ROC Armed Forces

Based on the Constitution and the public opinion, the position and mission of the ROC Armed Forces is to contribute loyalty to the nation, protect the people, and maintain the national security. All the servicemen have developed clear and steadfast understanding of the central belief of "what to fight for and whom to fight for." "What to fight for" is to fight for the "survival and development of the ROC," while "whom to fight for" is to fight for the "security and welfare of the people of the ROC."

III. Loyalty, Unity, and Best Performance in Military Duties

As the traditional virtue of the ROC Armed Forces, loyalty cultivates servicemen in the sense of "no covetousness, no fear of death, high patriotism, and people-loving." Therefore, the ROC Armed Forces is like a big family



Being Loyal to the Nation and Loving People are Inherent Duties of Servicemen

in which servicemen are united closely together, share same fates, and foster the esprit de corps. Since the establishment of the Military Academy in Whampoa, the ROC Armed Forces has always been maintaining the glorious traditions to show its loyalty to the nation, the Constitution, the people, and the responsibilities, focus its attention to best perform military duties, and conduct combat missions and trainings so as to establish a excellent force and assure national security.

IV. Vision

Abiding by the duties and obligations entitled pursuant to the Constitution, not only will the ROC Armed Forces continuously contribute its loyalty to the nation and the people, but also follow the norms like democratization, legalization, and equalization to conduct its designated duties in a patriotic, loyal, righteous, and legal way so as to enhance its positive images to the general public.



Maintain Esprit De Corps and Uphold Patriotism



Focus Attention on Combat Readiness to Establish an Elite Military Force

Restructuring of National Defense Organization

I. Origin

To cope with military threats from the PRC, ensure national security, and build a defense system of “shared responsibility and professionalism,” the MND, after taking into account a broad range of opinions, revised the draft bills of the “National Defense Law” and the “Organization Law of the Ministry of the National Defense” on April 30, 1998. These drafts were then presented to the Executive Yuan for review and to the Legislative Yuan for approval, and were legalized by the Legislative Yuan on January 15, 2000. The President promulgated these two Laws on January 29, 2000. These two Laws ushered in a new era for the professional restructuring of defense organization by enunciating the requirements of “all-out defense,” “integration of military administrative and command systems,” “the ideal of a civilian-led military,” “nationalization of the ROC Armed Forces,” as well as “specialization and division of expertise and meeting the military needs.” To speed up the implementation of these two Laws and the restructuring of the defense organization, the MND complied with the Legislative Yuan’s appended resolutions of the “Organization Law of the Ministry of the National Defense” to set up the “Organization Planning Committee,” subordinated by “Review and Coordination Conference” and 22 planning operation groups such as “Strategic Planning Department.” The above units are in charge of promoting and supervising the three stages of restructuring defense organization: planning (from January 29, 2000, to February 28, 2002), restructuring the organization (from March 1, 2002, to January 31, 2003), as well as finalizing the organization (from February 1, 2003) and putting the restructured organization into operation. The task of defense organization

reengineering must meet the requirements and be completed within the specified timeframes.

II. Planning Concept

1. Establish a National Defense System Complying with the Constitutional Democracy and Receiving Public Supervision

In the original national defense system, the President was the commander-in-chief of the ROC Armed Forces; the Chief of the General Staff (CGS) was the President's chief of staff, who commanded the troops under the President's orders. In the administrative system, the CGS was also the Minister of National Defense's chief of staff, and the President could directly command the troops through military conference. Such a mechanism and the division of power and responsibilities did not meet the requirements of democratic politics. Nevertheless, the Article 8 of the National Defense Law stipulates that "the President is the commander-in-chief of the nation's army, navy and air force, can exercise the authority to command the troops, give direct orders to the Minister of National Defense, and instruct him to order the CGS to execute the orders." This Article fully manifests that in accordance with the laws, the Minister of National Defense, can manage national defense affairs and must come under the parliament's direct supervision, in order to establish a national defense system meeting the requirements of constitutional democracy.

2. Construct a Specialized and Efficient Modern Defense Organization

In the original national defense system, all the affairs concerning military administration, military command, and military armament are undertaken in the General Staff Headquarters (GSH), with the primary source of professional staff coming from the military command system, and the technical staff from the military administrative and armament systems as auxiliaries. This explains why the current joint-operation capability is

insufficient. Furthermore, given that the military education system has long focused on the commanding of troops and that the requirements for managing current armaments as well as the C² systems are becoming increasingly professional, the “National Defense Law” and the “Organization Law of the Ministry of the National Defense” is designed to follow the principles like division of organization, personnel control, and separation of education, with an aim to improve the MND staff’s professionalism and to meet the requirements of a decentralized organization by reassigning GHQs of each service to the MND HQs’ jurisdiction, helping shorten operation processes.

3. Set up a Rapid-Response Operation Command Institution functioning in Both Peacetime and Wartime

Given the characteristics of “narrow in depth, short warning time and rapid decisive operation” of defense operations in Taiwan and Penghu, the design of the “National Defense Law” and the “Organization Law of the Ministry of the National Defense” aims to adjust the existing interrelated staff departments under the GSH and turn them into professional joint-operation command institutions. Through short rapid-response chain of command as well as modern command and control system, the status of the ROC Armed Forces can be fully under control, and the immediate responses can be made to face the conditions of operations so as to cope with current and future threats, ensuring national security.

4. Utilize Integrated National Strength and Fulfill Concept of All-out Defense

National defense means the security preparations taken to safeguard a nation’s territory, sovereignty and people. It cannot be achieved by pure military force alone but involves many interrelated dimensions, including political, diplomatic, economic, military, and psychological ones. Therefore,

the design of the “National Defense Law” and the “Organization Law of the Ministry of the National Defense” aims to transform the current defense mechanism from a conventional military force into a broadly defined all-out defense so as to meet the requirements of the constitutional system. Through the National Security Council, various departments and agencies under the Executive Yuan can be included in the national defense policymaking mechanism so that the nation’s resources can be integrated, the national strength fully utilized and the goal of all-out defense achieved.

III. Overview of Highlights of the National Defense Law & the Organization Law of the Ministry of the National Defense

1. The National Defense Law

(1) The National Defense Law stipulates that the ROC’s national defense is all-out defense, with dedicated chapters specifying the detailed measures on how to implement the all-out defense concept. The goal is to pool and integrate national strength so as to ensure the national security and development.

(2) The nationalization of the ROC Armed Forces specifically requires that the ROC’s army, navy and air force shall transcend individual, regional and partisan interests, and shall maintain political neutrality, in order to achieve “thorough nationalization of the ROC Armed Forces” as spelled out by the Article 138 of the Constitution.

(3) The MND is in charge of all national defense affairs and shall utilize its expertise in military administration, military command and military armament. Based on the needs of national defense security, it shall make suggestions on defense policy and formulate military strategies.

(4) The President can exercise the power of command to instruct the Minister of National Defense, who can subsequently order the CGS to carry out the orders.

(5) After restructuring, the GSH becomes Minister of National Defense’s

military command staff as well as the command institution for joint operations of the ROC Armed Forces. Under the order of the Minister, the CGS is put in charge of military command affairs and commanding troops so as to fulfill its professional functions.

2. The Organization Law of the Ministry of the National Defense

(1) The MND HQs: it is in charge of defense policy-making, military strategy, military buildup planning, resources planning and allocation, manpower planning, national defense regulations, court martial affairs, reserve affairs, military history and translation, national defense education, and other related national defense affairs as well as the supervision of the implementation of national defense policies.

(2) The GSH: it is Minister of National Defense's military command staff and the command institution for joint operations of the ROC Armed Forces. Besides, it is responsible for proposing requirements for military buildup and suggestions on the allocation of military defense resources, supervising combat readiness, units training, preparing operation orders, formulating and executing operation plans, and other related affairs concerning the commanding of troops.

(3) Setting up the Military Armament Bureau, the General Political Warfare Bureau (downsizing will be made within 3-year with additional 1-year extension if necessary), the Comptroller Bureau and the Medical Bureau, which are respectively in charge of armament preparedness, political warfare, accounting and statistics, and medical affairs.

(4) The GHQs of Army, Navy, and Air Force will be transformed into Command-level by February 1, 2003, with additional 1-year extension if necessary.

(5) Combined Services Headquarters has already been transformed into Combined Logistics Command and the Corps Control Area Command into Reserve Command. The GHQs of the Army, the Navy and the Air

Force as well as the Military Police Command will be reassigned to the jurisdiction of Minister of National Defense. The MND may reassign the aforementioned military organizations' units concerning the commanding of troops and operation units to the GSH.

IV. Intended Results

1. Thorough Nationalization of the Armed Forces

Article 6 of the National Defense Law stipulates that the ROC Armed Forces shall transcend individual, regional and partisan interests, and shall maintain political neutrality and shall not engage in promoting partisan affairs in the troops. The MND is fully aware that the ROC Armed Forces belong to the nation; therefore, it will stay detached and independent from all political parties, establish good interactive relationships with all political parties, and comply with the democratic and constitutional system, in order to achieve the goal of thorough nationalization of the ROC Armed Forces.

2. Integration of the MND Military Policy and Military Command

In accordance with the "National Defense Law" and the "Organization Law of the Ministry of the National Defense", the MND is responsible for handling all national defense affairs. The GSH, under the MND, serves as Minister of National Defense's military command staff as well as the command institution for joint operations of the ROC Armed Forces. The CGS, who takes charge of military command affairs and commanding of troops at the order of the Minister, heads the GSH. In accordance with the Organization Law of the Ministry of the National Defense, the GHQs of each service will be reassigned to the jurisdiction of the MND. Thus, a national defense structure with integrated military administration and military command will be in place after these two Laws take effect.

3. Realization of the Ideal of a Civilian-led Military

The National Defense Law specifies a national defense system under civilian leadership. Therefore, to prepare a civilian minister of national defense to better understand defense affairs, the number of staff departments under the MND has increased sufficiently after the Organization Law of the Ministry of the National Defense was revised. As a result, the Minister of National Defense will have access to well-rounded staff and sufficient channels of consultation that can assist him in defense policy-making. The Minister will also be able to fully supervise and review the allocation and results of defense budget so as to successfully carry out national defense policy.

4. Promotion of Specialization and Division of Expertise and Efficient Integration

The National Defense Law specifies a national defense system that unifies military administration, military command, and military armament. The military administration system is in charge of “force construction,” formulating defense policy and strategy, force construction planning and guidance, raising resources, making policies, as well as supporting the functioning of both military command and military armament systems. The military command system is in charge of “military readiness,” making operation plans, formulating requirements for operations, supervising combat readiness, and commanding joint operations of the ROC Armed Forces. The military armament system is in charge of “armament readiness,” capacity buildup, and supporting the needs of military command operations. The military policy, military command, and military armament systems complement one another. Together they combine to constitute an integrated national defense system that can enhance the functioning of national defense affairs and effectively meet the requirements for defense operations.

5. Establish a Refined National Defense Organization

The GHQs of each service originally under the GSH will be reassigned to the jurisdiction of the Minister of National Defense. This will refine and streamline the administrative systems to bring about a de-layered defense organization. Nevertheless, in order to smoothly command troops and carry out missions, the MND may reassign departments concerning commanding of troops and operation units originally under the GHQs of each service to the jurisdiction of the GSH.

6. Sustain the Sound Strength of the Armed Forces

The greatest threats to the ROC's national security are posed by the PRC. The key to defeating enemy and securing victory lies in the integration of both intangible and tangible defense forces. With the subsequent acquisitions and line-ups of new-generation armaments, the ROC Armed Forces have increasingly strengthened their tangible force. After the enactment of the National Defense Law and the Organization Law of the Ministry of the National Defense, an appropriate organic structure will be created, the number of commanding levels be decreased, and the structure of the ROC Armed Forces be adjusted, resulting in great improvements in the intangible force. With strong tangible and intangible forces combined, the ROC Armed Forces will become a specialized and efficient modern force in the future.

7. Comply with the Government's Policy of Raising Administrative Efficiency

In order to effectively raise administrative efficiency and to comply with the "Draft of the Standards Law for the Organization of the Central Government Agencies" that manifests the spirit of a rationalized professional organization, a clear structure, and a downsized workforce, the MND will adjust the structure of its subordinated departments as well as reduce the

number of administrative levels within the national defense organization. Besides, the MND will revise the number of workforce and regulate that the number of civilian employees shall not be lower than one-third of its staff. This will enable the MND to recruit a large number of civilian officials after the Organization Law of the Ministry of the National Defense takes effect.

V. Vision

Restructuring national defense organization is so complex and difficult, and cannot be done overnight. The MND will adopt a positive and steadfast attitude to carry out the related procedures. Besides, the MND will review the implementation status of the aforementioned two Laws after 6 months of their enactments so as to fine-tune its steps to develop a fully functional and sustainable national defense organization.

2002
NATIONAL DEFENSE REPORT

Implementation of All-out Defense

I. Objectives

1. To create a complete legal mechanism for mobilization so as to lay down a solid basis to mobilize.
2. To encourage the people to participate in the discussion of all-out defense so as to foster a consensus on it.
3. To realize functions of the administrative mobilization conference so as to grasp the overall combat potential and effectively support defense warfare.
4. To enhance the readiness of military mobilization so as to create a reliable combat strength.
5. To blend mobilization within the policy implementation domains and combat strength within economic infrastructure so as to consolidate the national defense and the people's livelihood for defense purposes.
6. To organize legally established armed and civil defense groups, and to merge them into order of battle.

II. Implementation Status

1. After years of through discussions, the "Regulations of All-out Defense Mobilization Preparation" has finally enacted in November 14, 2001 to replace the "All-out Mobilization Law." In order to facilitate the implementation of combat preparatory plans, the regulations stipulate to enact 16 subsidiary regulations (the MND is responsible for drafting 9 regulations, and relevant governmental agencies are responsible for the rest 7). Enactments of the aforementioned regulations are slated for completion by 30 Jun. 2002.
2. Through plural ways like academic seminars (3 times), internet Q&A lotteries (joined by 141,014 persons) and request of articles (1,245 pieces) and unit tours (2 times), the MND has promoted the ideals, such as "organic community" and "all-out defense" so as to enhance the people's aware-

ness toward our national destiny, and to win their approval and support to the national defense.

3. Since Feb. 2001, the MND has called up 114 relevant governmental employees to participate all-out defense mobilization seminars for the sake of enhancing their understanding of the functions and mechanism of the military mobilization. "Regulations of the Establishment of the All-out Defense Mobilization Preparatory Conference of the Executive Yuan" was enacted on January 14, 2002 with an aim to establish a well-defined mobilization system. The All-out Defense Mobilization Preparatory Conference of the Executive Yuan was formally established on June 13, 2002 so as to create mental defense and civil defense systems, which are equivalent to military defense systems.

4. According to the principle of "proper management, organization, equipment, training, and utilization," the MND implements training, review, and service muster-calls to enhance readiness of the reserved weapons and reserve personnel so as to assist the regular force in wartime, and fulfill the goal of accurate mobilization, fast reorganization, and rapid recovery of combat strength.

5. Through all-out defense mobilization mechanism, mobilization preparatory process is blended with the policy implementation procedures of local governments so as to integrate defense establishment and local economic infrastructure. According to "National Procurement Law," "Regulations for the Private Sector Entrusted with Management of Technological Industries by the MND" and "Regulations for R&D, Production and Maintenance between the MND's Technological Industries and Private Sector," the MND will continuously set up relevant plans to strategically maintain military items through commercial channels. Besides, the MND will promote privatization of defense industries to assure normal supply of military items so as to efficiently support combat readiness.

6. The MND will incorporate legal armed groups into the order of battle

in Hankuang Exercises and Combat Readiness Trainings so as to enhance their combat capabilities. Besides, according to “Civil Defense Law” and “Disaster Prevention Law,” civil defense groups, police and fire forces as well as students are to be mobilized during Wang-an Exercises to complete the missions to support military operations and maintain social order.

III. Mobilization for All-out Defense

The mobilization for all-out defense is a tangible way to implement all-out defense concept. In peacetime, such mobilization combines with the policy implementation in local governments so as to accumulate overall combat capabilities in realms like personnel, material, and combat strength, and to assist in dealing with local contingencies.

1. Missions:

(1) Preparatory phase: Complete preparations in dimensions of manpower, material, finance, technology, military and combat capabil-

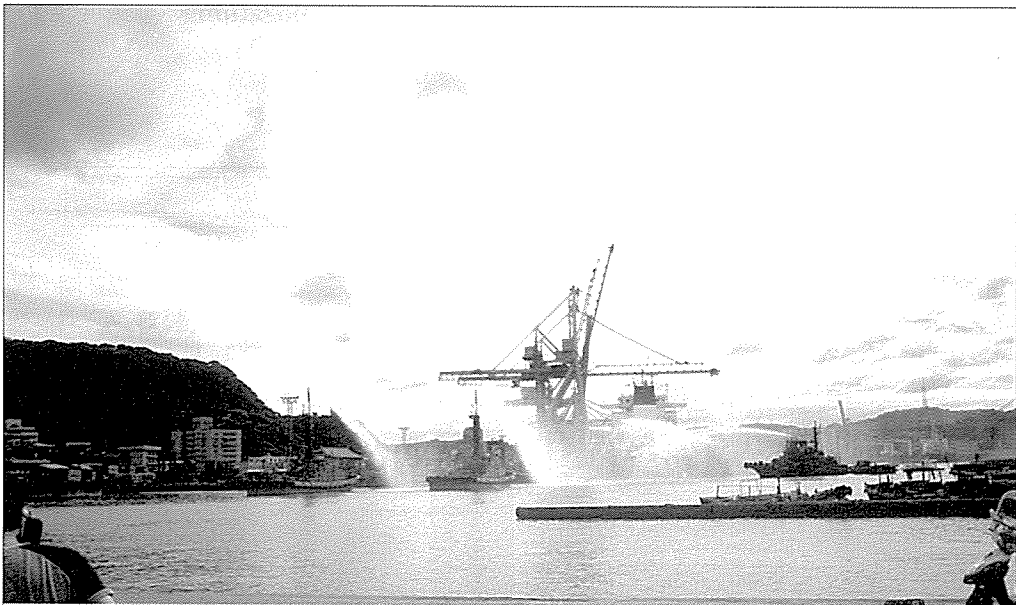

Naval Firefighting Maneuver in Wan-an Exercise

ity in coordination with the administration according to the “Regulations for Preparation of All-Out Defense Mobilization” to lay solid foundations. Support the efforts for disaster prevention and relief pursuant to Rules for Disaster Prevention and Relief.

(2) Implementation phase: Initiate general or partial mobilization in accordance with “Emergency Decree,” utilize national economic strength to establish combat capability to support military operations and emergency relief efforts, and maintain emergency response capability of government agencies and fulfill daily necessities of civilians.

2. Mechanism and Organization of Mobilization

Only does mobilization of the overall national resources to extend all-out defense strength can respond to future combat situations in which the PRC launches its military threats. Currently, the mobilization mechanism is divided into two systems: administrative mobilization system and mili-

Figure 6-1 Mechanism of National Mobilization

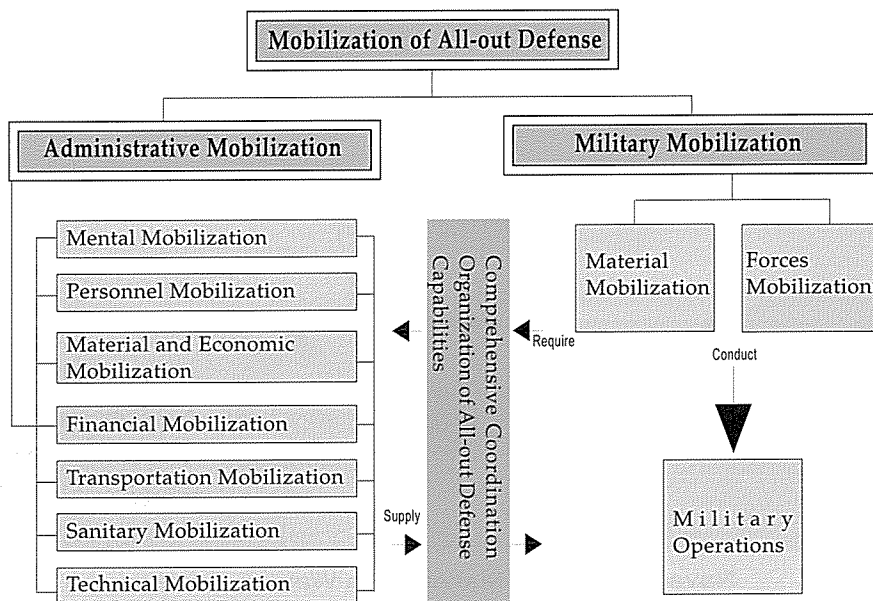

tary mobilization system. In wartime, the MND can integrate necessary resources via administrative mobilization achieved by central and local governments, and accomplish combat mission via military mobilization. Besides, the Comprehensive Coordination Organization of All-out Defense Capabilities acts as interface between these two mobilization systems. (Figure 6-1)

(1) In order to perform functions of the mechanism, the mobilization organization of all-out defense combines administrative system, and adopt the way of holding conferences to formulate two directive systems: Directive Mechanism of Mobilization Conference Related Affairs, and Directive Mechanism of Mobilization Planning.

Figure 6-2 Mechanism of All-out Defense Mobilization Conference

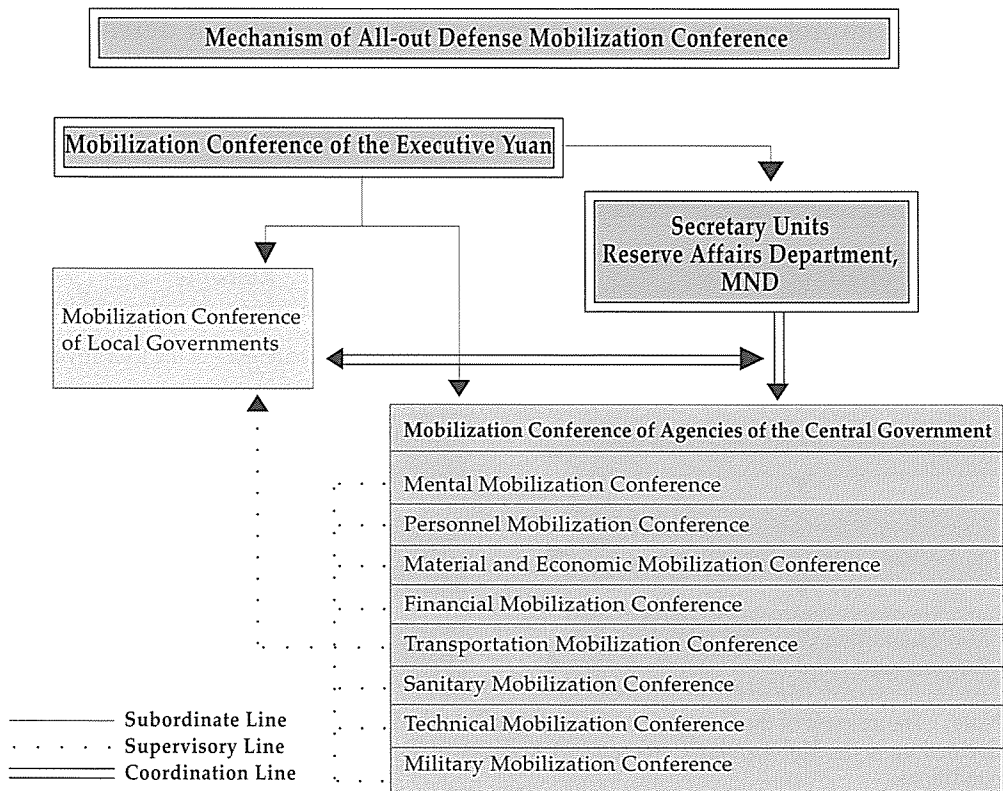

a. Directive Mechanism of Mobilization Conference Related Affairs

Mobilization conference of agencies of the central government and mobilization conference of local governments are directed through the Mobilization Conference of the Executive Yuan. (Figure 6-2)

b. Directive Mechanism of Mobilization Planning

Directive mechanism of all-out defense mobilization program is formulated according to guidelines of mobilization preparation, proposals for mobilization preparation, categorized sub-proposals of the proposals for mobilization preparation, and implementation plans for mobilization preparation. (Figure 6-3)

(2) Comprehensive Coordination Organization of All-out Defense Capabilities

With regard to integrate human and material resources within theaters, the “comprehensive coordination organization of all-out defense capa-

Fig. 6-3 Directive Mechanism of All-out Defense Mobilization Program

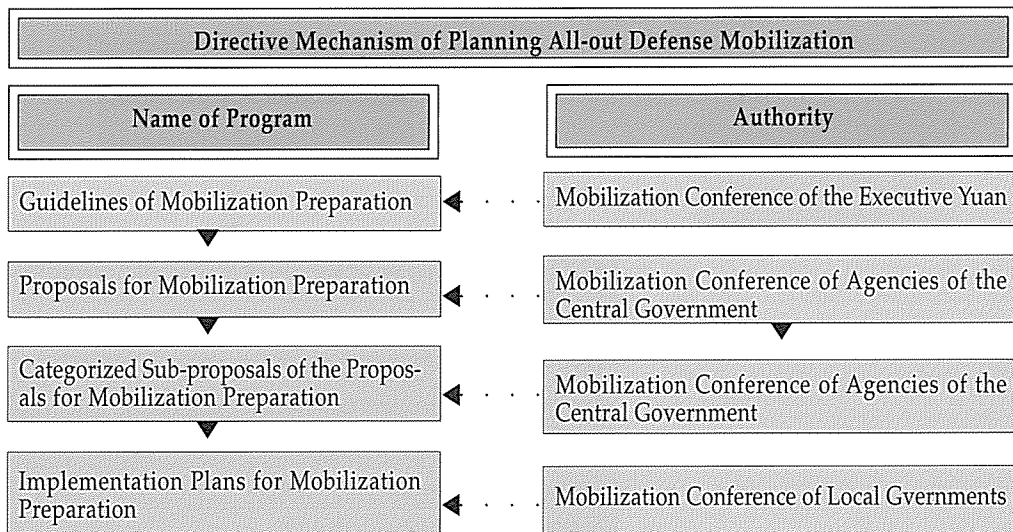

Note: The amount of the Categorized Sub-proposals of the Proposals for Mobilization Preparation is decided upon the Mobilization Conference of Agencies of the Central Government according to actual conditions.

bilities” is therefore created to establish effective combat-support strength of all-out defense. Besides, this organization can assist in local government to deal with disaster relief operations, and acts as a mobilization interface among political, military and civil organizations. In peacetime, the organization will adopt the way of holding “comprehensive coordination conference of all-out defense capabilities” to implement mobilization related affairs. In wartime or during disaster contingencies, this organization will be transformed to be “comprehensive coordination center of all-out defense capabilities” to jointly and properly manage human and material resources across the board. “comprehensive coordination conference of all-out defense capabilities” is held in 3 levels: Taiwan and Fujian areas as the first, theaters and municipalities as the second, local cities and counties as the third.

IV. Vision

Concerning the status quo of the nation and the strategic environment, the MND will actively coordinate with government agencies to incorporate relevant education in order to promote recognition of the nation and the importance of national defense. It’s hope that the people can thus reach consensus and confidence on national policies so as to support and participate in defense affairs. In addition, a complete administrative mobilization mechanism and a well-found military mobilization mechanism are formulated on a legal basis so as to accumulate comprehensive national power in peacetime and integrate into a capable national security mechanism of all-out defense in wartime. Having this mechanism combining peacetime and wartime usages, the national survival and development, and the people’s livelihood and property therefore be assured and the realization of all-out defense concept can be achieved.



Comprehensive Coordination Organization for All-out Combat Capabilities



All-out Defense Needs Civil Support

Military Education

I. Objectives

Military education is the prerequisite of military buildup. Since the “Regulation of Military Education” was passed by the Legislative Yuan and the new generation military forces was established, the ROC Armed Forces has, following the educational laws and regulations, enhanced the military education quality. In addition, for the purposes of educating highly qualified professional cadres with high-tech specialty, the ROC Armed Forces has built up a brand-new, macroscopic, forward-looking military education system, formulated military development policies, improved all teaching methods, and actively encouraged life-long learning. With these accomplishments, the ROC Armed Forces can educate first-rate servicemen and entirely enhance its manpower quality, so that these people can not only respond to the challenges of the new century, but also contribute their learning and capability to the society.

II. Policy

1. Forming the Characteristics of the Preparatory School

Persisting in attaining the goal of “holistic education” and exalting the importance of “soldiers’ characteristics,” the Chung-Cheng Armed Forces Preparatory School has promoted balanced development of the five aspects of education (ethical, intellectual, physical, group spirit and aesthetic), in hopes to build up a firm foundation for cadets with an integrated and sound education system.

2. Planning the Merging of Colleges, Departments and Graduate Schools

To increase the utilization efficiency of educational resources, and also to follow the principal of “establishing for practicability,” all primary col-

leges and existing departments and graduate schools are put under review to be streamlined. The merging is carried out by the following principles:

- (1) Departments or graduate schools that are close in nature and function shall be merged.
- (2) If establishing a department is not efficient, private educational resources shall be used, and the task shall be undertaken by contractors with the private sector.
- (3) Departments and graduate schools of the same academic fields shall be set up by the mode of "merger of the department and graduate school."
- (4) Departments' names in primary military colleges shall be identical to those in private colleges, so that the former can be integrated into the entire educational system of the country.

3. Improving the Curriculum Design

(1) Fundamental Education

- a. The "core curriculum" is to be designed according to the minimum of 128 credits in universities. Also in coordination with "specialized tracks" plans, courses are divided into required and elective ones, which can shape up the focus of education. In addition, the "holistic education" curriculum is to be planned, hoping to strengthen the cadre-developing education by integrating soldiers' virtues, leadership, military expertise, physical strength and combat skills into the course.
- b. Teaching and academic exchanges between military and civilian schools are encouraged (for example, intercollegiate course-taking), so that local educational resources can be utilized, civilian and military teaching integrated, and education quality enhanced.
- c. Professional military education is to be implemented during winter and summer vacations. The curriculum is mainly cadre-developing and basic military training, so that basic military knowledge and skills can be implanted into cadets.

(2) Command and Staff and Strategic Education

- a. The curriculum planning of command and staff education gives priority to “commanding of troops” and secondary importance to “military buildup and armament.” The curriculum includes required courses, covering tactics, the history of war, information management and C⁴ISR, as well as elective courses, covering military specialty relating to the cadets’ expertise, special skills and their designated positions.
- b. Strategic Education gives priority to “military buildup and armament” and secondary importance to “commanding of troops.” The curriculum includes required courses, covering “national security,” “strategies of services” and “integration and distribution of resources,” as well as elective courses, covering “military tactics,” “regional study” and “information and electronic warfare.”

4. Establishing Advanced Education Policy

(1) Advanced Military Study

Responding to the demands of military buildup and armament, the ROC Armed Forces selects potential ranking officers and national defense administrators. The approaches of “recommendation first and examination second for the strategic class, examination first and recommendation second for the command and staff class, and designation in advance” are adopted, hoping to reach the goals of “training for using; selecting for training; training and immediate using; combining selecting and training,” so that mid- and high-ranking officers are capable of comprehending tactics and strategies, and furthermore, guiding the policy-making in terms of military buildup and armament of the ROC Armed Forces.

a. Command and Staff Education

(a) Command and Staff class: each department of different services in the military colleges, National Defense University (NDU), is responsible for educating and training mid-ranking command and staff officers,

as well as equipping them with capabilities of commanding troops and operations.

(b) Class for advanced study: related classes are to be opened by the Fu Hsing Kang College, the NDU National Defense Management College, the Military Intelligence College and the Logistics and Mobilization Management College. They are responsible for educating and training mid-ranking professional officers and cadres, in hopes that they can efficiently help complete military missions and enhance fighting abilities of the ROC Armed Forces.

b. Strategic Education

(a) Regular strategic class: to be opened by the strategic departments of NDU military colleges. The goal is to train command and staff officers to be able to make policies, improve strategies and command joint operations, and to equip them with capabilities of undertaking military buildup, armament and joint staff planning.

(b) National defense management strategic class: to be opened by the NDU National Defense Management College. The goal is to educate officers to be able to make policy and utilize national defense resources in terms of military buildup and armament, and to equip them with capabilities of guiding logistics support for joint operations.

(c) Graduate Institute of Strategic Studies: to be held by the NDU Graduate Institute of Strategic Studies. The goals are to develop a national defense think-tank, and to train policy-making officers and teachers for further study.

(2) Pursuing Master's Degrees and PhD Degrees.

a. Encourage military officers to pursue a master's degree as a primary goal and a Ph. D. degree as a secondary. Officers interested in a master's degree can apply for the training through an open selection system; the goal is to help officers develop a second field of specialization and im-

prove their quality. Officer candidates for the Ph. D. training, however, are selected through a planned selection system; the goal is to cultivate future faculty members and professional talents for hi-tech research. Based on the trainees' specialties, relevant departments and programs are set up, a suitable number of officer students are admitted, and future assignments of these officers are planned in advance, so as to meet the objective of "integrating training and using."

b. Military officers' pursuing advanced study is limited to the primary fields of management, information, and related subjects and the secondary fields of engineering, literature and law that are essential for the development of national defense and military buildup. Furthermore, study in graduate schools in Taiwan takes precedence over study abroad. (Training abroad is only allowed on the premise that there are no same departments and programs available in Taiwan; there are special military needs; or the studying is in internationally renowned schools.)

5. Bettering the Quality of Faculty

(1) To effectively better the quality of faculty, all military colleges and academies are required to obey the strict requirements that all newly recruited faculty members (both military and civilian) must hold a Ph.D. degree or at least an assistant professorship and that 62% of all faculty members must hold a Ph.D. degree or at least an assistant professorship by the end of 2003. Civilian teachers employed by secondary military schools must have a master's degree and a teacher's certificate of qualification for secondary education.

(2) Faculty for the teaching of command and staff, and military strategy are selected by the ROC Armed Forces from those who have studied military strategies and researched military tactics at home or abroad. Those with a Ph.D. degree or a master's degree in national defense affairs, information, management and other "related military fields of special-

ization" are preferable candidates. For the teaching of "general knowledge courses," respectable and renowned scholars are invited to hold seminars so as to comprehensively improve the content and quality of education.

(3) Integrate teaching and research resources of the military schools, and collaborate with civilian universities on course offerings so as to refine and improve the content and quality of teaching. In addition, encourage faculty members to engage in intercollegiate academic research and publish research results in journals at home and abroad, which will add to their qualification for promotion. This will effectively upgrade the overall quality of faculty members.

6. Promote Lifelong Learning

(1) In line with the concept of "establishing a learning society" promoted by Ministry of Education and the "national certification system" designed by Council of Labor Affairs, the ROC Armed Forces is planning to create a lifelong learning environment for military cadres to acquire second specialty and a better career planning so as to better the quality of military manpower.

(2) Lifelong learning for the ROC Armed Forces is divided into three categories: pursuing an academic degree, getting a certificate, and receiving specialty training. The principle for promoting lifelong learning is to encourage officers to "pursue a master's degree as a primary goal and certificate as secondary" and encourage NCOs to "acquire a certificate as a primary goal and pursue a degree as secondary" both in their "free time" and "at their own expenses."

III. Features of Military Professional Education

1. Developing Vocational Education

The goal is to cultivate NCOs with a healthy and whole character as

well as professional skills and functions, and teach NCOs with complete curricula of both senior high school and junior college so that they will possess both military and civilian professional functions. Guidance and assistance are also provided to them in acquiring a certificate so as to refine their professional skills.

2. Establishing Departments Indicative of Military Professionalism

The military academies are grounded on university education. All colleges can establish “special departments indicative of military professionalism”(Note 3) based on their objectives of education, service characteristics, visions, traditional features, as well as the requirements for combat readiness and buildup of new-generation forces. The underlying principle for the curricula is to develop holistic education through design-



Holistic Education Is the Main Body of the Curriculum of Military Education

ing the core curricula and study schedules as well as determining the educational focus, with the ultimate goal of facilitating officers to obtain a master's degree.

3. Emphasizing Information, Management and Foreign Languages Curricula

(1) The information education has the objective of strengthening students' capabilities of using computers and managing information systems. The focus for information curriculum design at military schools and academies is on the capability of connecting to the Internet and utilizing related software. As for the education of command and staff, and tactics, the focus is on the issues of network security, information warfare, and C⁴ISR.

(2) The focus of management education is on the theories of management, organizational behavior and the basic science of law. All fundamental military schools should adopt a "practice & honor" system for students to learn how to lead and manage troops. In addition, the private sector is commissioned to offer courses such as "basic management class for officers," "business administration for mid-ranking officers," and "advanced management seminars" for military cadres at all levels, in order for them to sharpen their management skills.

(3) The focus of foreign languages education is to improve the English abilities of listening, speaking, reading and writing of all students in fundamental military schools. Besides, there are language centers that train people to acquire fluent English proficiency and provide preparatory professional English training to personnel on missions abroad. Training of other languages (such as Spanish and French) is outsourced to other special institutions to meet the requirements of training of the U.S. FMS (Foreign Military Sales) programs .

4. Establishing the Highest Military Academic Institution-the National

Defense University

In accordance with the “Regulations of Military Education” and “University Laws,” the highest military academic institution, the NDU is a comprehensive and innovative school that demonstrates not only the “national defense military features” but also a broad international perspective. The mission of the NDU is to cultivate research talents on defense tactics for all levels of government agencies as well as to cultivate leadership in military strategy, tactics research, national defense management, and technological service for the Armed Forces. Besides, the NDU also serves as a national defense think tank.

Note 3: for example, the Chinese Military Academy has eight departments (Electrical Engineering, Mechanical Engineering, Civil Engineering, Computer Science, Physics, Chemistry, Management Science, and Political Science). The Chinese Navy Academy has five departments (Applied Science, Oceanography, Naval Architecture and Marine Engineering, Electrical Engineering, and Information Management). The Chinese Air Force Academy has four departments (Aerospace Engineering, Aeronautical Electrical Engineering, Aeronautical Mechanical Engineering, and Aeronautical Management). Fu Hsing Kang College has five departments (Political Science, Journalism, Social Work, Psychology, and Fine Arts). The National Defense Management College has five departments (Law, Information Management, Business Administration, Accounting, and Statistics). The National Defense Medical Center has five schools (Medicine, Dentistry, Pharmacy, Nursing, and Public Health). The Chung-Cheng Institute of Technology has eleven departments (Mechanical Engineering, Civil Engineering, Surveying and Mapping Engineering, Aeronautical Engineering, Applied Physics, Computer Science and Technology, Electrical Engineering, Weapon System Engineering, Vehicle Engineering, Naval Architecture and Marine Engineering, and Applied Chemistry).

IV. Vision

1. Planning Concept for the Future

The objective of fundamental education for military officers is to cultivate modern officers who are adept in both learning and action, as well as technically capable and morally sound. With comprehensive university curriculum that puts weight on holistic education, they will form the habit of independent learning, which will be of great help in their pursuit of fur-

ther study. The objective of education for NCOs is to cultivate military cadres to acquire at least a junior college degree, and following the vocational education-oriented guideline, assist NCOs in obtaining technical certificates based on the existing vocational training.

As for advanced education, the command and staff education is based on the professional functions of each service and the practical management of units. The objective is to cultivate cadres for combat readiness who will have a logical and integral thinking toward work. The education of strategy is based on national military strategy and defense resources management. The objective is to cultivate cadres for military buildup who will have an innovative, foresighted, and broad perspective.

2. Vision of Development

- (1) Aspire to be technically capable and morally sound; cultivate cadres adept in both learning and action.
- (2) Adopt foresighted requirements of military buildup; educate excellent top brass of the 21st century.
- (3) Study military strategies and tactics in depth; establish military academic reputation.
- (4) Promote lifelong learning; stimulate all to fulfill their ideals.

Training of the ROC Armed Forces

I. Operational Exercises and Training

The goal of operational exercises and training is to validate adaptability and feasibility of the operation plans; that is, to familiarize the ROC Armed Forces with the combat skills of joint operations, and to solidify troop training. Operational exercises and training must be implemented according to schedules despite all difficulties. In particular, the frequency of exercises should not be reduced or the training standards be lowered due to any outside interferences.

On the premise of no interference to national training missions, no additional forces, annual operational exercises and trainings are divided into four categories: "operation," "mobilization," "nuclear and chemical warfare," and "general training" according to the policy of "Streamlining Exercises and Trainings Missions, Establishing Command Mechanism of Joint Operations." Based on summarized scenarios and designated conditions, the GSH will be responsible for all the planning and management in this regard so as to establish joint operation concept in every aspect and effectively enhance overall combat strength.

There will be a total of more than 150 exercises in the four categories of operation, mobilization, nuclear and chemical warfare, and general training in FY 2001 and FY 2002. All the exercise plans have been included in the annual training directions in order to ensure that all exercises and trainings are carried out according to specified plans and procedures. The main exercises and trainings in FY 2001 and FY 2002 are listed in Table 6-1.

II. Verification of Results of Physical & Combat Trainings

1. Purpose

The purpose is to review the results of physical training and combat

Table 6-1
Main Exercises and Training of the ROC Armed Forces in FY 2001

Category	Title of Exercise	Characteristics	Schedule	Remarks
Operation	Hankuang No. 17 Exercise	Training efficiency review of the Armed Forces joint defense combat exercise	March, April 2001	
	Hankuang No. 18 Exercise		April, May 2002	
Mobilization	Tunghsin No. 13 Exercise	Mobilization of civilians	March, April 2001	in conjunction with Hankuang Exercise
	Tunghsin No. 14 Exercise	Material Mobilization	May 2002	
	Chihchang No.19 Exercise		March, April 2001	
	Chihchang No.20 Exercise		May 2002	
	Wan-an No. 24 Exercise		Military-civilian joint air defense	
	Wan-an No. 25 Exercise		June 2002	
Nuclear and chemistry	Hua-an Drill 2001	Drill of toxic chemicals disaster relief	May, per year	Hosted by Environmental Protection Agency
	Hua-an Drill 2002			
	Ho-an Drill 2001	Nuclear power plant accidents emergency drill	June, Aug. 2001	Hosted by Atomic Energy Council
	Ho-an Drill 2002		July 2002	
General	Seminar for highranking military cadres 2001	Study of Current Circumstances	February 2001	Four sessions
	Seminar for highranking military cadres 2002		June 2002	
	General Review of the Armed Forces' Combat Skills 2001	Training efficiency review of the Armed Forces' combat skills	Nov., Dec., per year	
	General Review of the Armed Forces' Combat Skills 2002			
Training	Lienhsing No. 84, 85 Drill	Training Efficiency Review of the Amphibious Forces	April, Nov. 2001	
	Lienhsing No. 87, 88 Drill		May, Aug., Nov. 2002	
	Lienhsin Drill 2001	Combined Combat Training of the Vessels and Coastal Artillery	Once a quarter	
	Lienhsin Drill 2002			
	Lienyun No. 65 Drill	Training Efficiency Review of Parachute Forces	April 2001	in conjunction with Hankuang Exercise
	Lienyun No. 66 Drill		May 2002	
	Shanjian No. 41, 42 Drill	Training Efficiency Review of Air Defense Combat Readiness	April, Nov. 2001	in conjunction with Hankuang Exercise
	Shanjian No. 43 Drill		May, Nov. 2002	
	Shenkung No.7 Exercise	Training Efficiency Review of Air Defense Combat Readiness	July, Oct. 2001	
	Shenkung No.8 Exercise		May, Nov. 2002	
	Training of Joint Fire Support Coordination Mechanism 2001	Coordinated training of different services and anti-ship landing shooting	April, Aug. 2001	
	Training of Joint Fire Support Coordination Mechanism 2002		March-Oct. 2002	

skills training of the ROC Armed Forces, nourish team spirit, and upgrade combat capabilities of the ROC Armed Forces by conducting a general assessment on the premises of fairness, reasonableness and normalcy.

2. Planning Concept

The concept is to provide guidance and assistance to the planning of normal combat readiness exercises and training of the ROC Armed Forces in accordance with annual training directions, to define division of responsibilities for the annual assessment of physical training and combat skills training, and to establish assessment items and standards. The assessment will be conducted through both general assessment and sampling assessment and based on the principle of great reward and heavy punishment, in order to stimulate the troops' desire for training, strengthen the build of servicemen, and improve the efficiency of combat skills training.

3. Measures of Implementation

(1) Division of Authorities and Responsibilities:

- a. The MND: it works in conjunction with the GHQs of each service to conduct general assessment of training efficiency in every November.
- b. GHQs of each service: each one is in charge of general assessment of training efficiency and grading assessment results of its service.
- c. Army Corps (or equivalent units in the navy and the air force): they conduct assessment of training efficiency of the units under their jurisdiction once every six months.
- d. Combined Arms Brigade (or equivalent units in the navy and the air force): they conduct assessment of training efficiency once every three months.

(2) Categories of Assessment:

- a. Physical strength: the main assessment items are "sit-up, pull-up and 3,000-meter run."
- b. Combat skills: units assessed in this category are divided into five groups, including ground force (combat, combat support, and service support), naval ships and flight units. Based on the nature and mis-

sions of each service, GHQs of each services can set up its own assessment standards and regulations for the specialties of their units.

c. Various competitive activities: every year various competitive activities such as team sports, field and track events, and swimming are planned separately by GHQs of each Service, with an aim to stimulate units' team spirit and cultivate its psychological power.

(3) Targets of Assessment: the main targets of assessment are units receiving training at bases as well as individuals who have completed basic training.

(4) Methods of Assessment:

a. The assessment of units below Army Corps level (including Army Corps) is carried out by executive agencies on the site of the units' bases.



Naval Light Arms Live-fire Test

b. The general assessment of each Service is conducted separately by its general headquarters. Based on the different regions where units are located, the assessment will be implemented at either the site of units, barracks, or unit stations. The MND will set up an inspection team to review the whole process of assessment.

c. Units below Army Corps level (including Army Corps) will adopt overall and general assessments. The three services will adopt sampling assessment, with the MND drawing lots to decide the units to be assessed one week prior to the assessment.

The assessment of physical strength and combat skills of the ROC Armed Forces aims to evaluate the training efficiency of all units. In order to enhance the overall training efficiency of the ROC Armed Forces, the assessment results are given in terms of "passing rate" instead of scores, and all units are strictly forbidden to adjust their regular training timetables during the assessment period.

III. Reconstruction of Training Bases

1. Policy Guidance

(1) In accordance with the policy of "national defense and people's livelihood as one," the planning of training bases and facilities for troops of all levels is geared toward "interoperability," "modernization," "standardization," and "systemization," with the hope of reducing training accidents and enhancing the security of troops and civilians. Building general training bases for the three Services and abolishing or merging small ones are planned, putting into consideration factors such as the number of troops, training requirements, local development and environmental protection.

(2) Plans are made to actively promote and develop "training simulators" for all levels and to build large general training bases and maritime and air training fields for the three Services. This will contribute to sav-

ing public funds and effectively supporting the training of troops.

2. Review on Status Quo

Currently the ROC Armed Forces' training fields can be roughly divided into four categories: physical strength and combat skills training grounds (653), light weaponry shooting galleries (100), platoon combat shooting and inhabited ground war training grounds (20), as well as the Armed Forces cannon shooting galleries (21). These training grounds come to a total of 794 and cover about 8,563 hectares. Of this size of land, 911 hectares are owned by the government, 173 hectares by civilians, and 1,277 hectares illegally occupied by civilians (the MND has resorted to legal action on this issue). Most of the physical strength and combat skills training grounds are located inside or near barracks and thus can barely meet the training needs of troops. However, the other 3 categories (141 in total) of training grounds have demonstrated a clear insufficiency, which creates a huge negative impact on the training and combat capacity of the ROC Armed Forces.

3. Methods of Improvement

(1) Formulate the "Five-Year Administrative Plan for the Development and Use of Training Grounds." Review the priority, method, work plan, required time, and required budget for the handling of all training grounds on a case-by-case basis.

(2) For the privately or publicly owned lots that are occupied, borrowed, or rented out, reviews must be conducted on how to swiftly return the lots if the lots are vacant or not reserved for any plans. If the lots are reserved for use after review, they must be put on priority list and included in the five-year administrative plan for acquisition (budget allocation) in phases over the years.

(3) Considering the factors of safety, future streamlining of troops, de-

fense structure reorganizing, and training equipment updating, training grounds that are poor, outdated or pose safety threat must be quickly abolished in order to lessen management difficulties.

(4) In order to sustain the combat capability of the ROC Armed Forces and ensure national security, the integrity of units' training grounds must be preserved. The ROC Armed Forces will continue to strengthen their relations with civilians, cultivate a good military-civilian rapport, and establish effective channels of communication, so that units' combat readiness training can be carried out smoothly.

IV. Vision

Despite the fact that modern weaponry and equipment are becoming increasingly sophisticated, the key to bringing combat capacities into full play hinges on whether personnel are well trained or not. With the completion of the "the ROC Armed Forces Refining Program," new-generation forces have been formed and hi-tech weaponry and equipment subsequently acquired. This renders the old training models insufficient to meet the requirements of modern warfare. To build up a "specialized, modern, and effective" armed forces and achieve the goal of combining fighting and training, the future training of the ROC Armed Forces will follow the tenets of "training for fighting" and "safe training," based on units' missions, strategic planning, armament requirements, and the prerequisites of "strictness and toughness." Future training will be oriented toward the objective that "training enhances combat readiness, and combat readiness attests training," and will adhere to the principles of "integrating personnel and equipment, and advancing combat readiness," as well as pursuing the following six training directions:

1. With combat readiness missions as core, ensure integration of fighting and training.

2. Eliminate obstacles to training; adhere to the nature of fighting and training.
3. Promote specialty combination training; establish basic combat capabilities.
4. Emphasize training for joint operations and night operations; raise overall combat capabilities.
5. Allocate training resources wisely; achieve efficient and effective training.
6. Rigid environment for training assessment; establish and evaluate combat capability indicator.

In the future, the ROC Armed Forces will continue to assess and verify the training results of the new-generation forces, raise the efficiency of joint operations, integrate the army, navy and air force into a sturdy and solid "combat body," and effectively improve the overall combat capabilities of the ROC Armed Forces.

Military Exchange

I. Military Exchange and Cooperation

In coordination with the overall foreign policy of the Ministry of Foreign Affairs (MOFA), the MND continues to promote military exchange and cooperation with friendly nations, so as to raise the ROC's international visibility, and thereby to enhance the interaction and strengthen the friendship between the ROC and other nations, and furthermore, to gradually develop and expand friendly relations with neighboring states.

On 11th Mar. 2002, the Minister of the National Defense was invited to take part in "the United States-Taiwan Defense Summit 2002," sponsored by the private U.S.-Taiwan Council. It's believed that such summit has positive effect on the stability of the Taiwan Strait. Besides, the ROC Armed Forces has finished many military cooperation with friendly nations, such as mutual military visits, combat training cooperation, etc. Such cooperation efforts, which have done a lot of positive effects on combat readiness of the ROC Armed Forces, have received high approval and appraisal from friendly nations.

II. Study of Cross-Strait Military Mutual Confidence Mechanisms

1. Summary

The establishment of cross-strait "military mutual confidence mechanisms" has long been an issue that arouses wide concerns. Accordingly, in coordination with the government's policy and guidance, the MND convened a conference in July 2000 to broadly seek different views from all parties. The attendants invited included personages and experts from the industrial sector, the government and academia. In addition, an ad hoc committee was set up in the same year. The committee, according to the

Guidelines for National Unification, studied related issues and mapped out near-, mid- and long-term plans to establish the foresaid mechanisms. These plans were given to the MND for its information and improvement in terms of policy making.

2. The MND's Present Perceptions on Establishing Cross-Strait "Military Mutual Confidence Mechanisms"

(1) Objectives

- a. Increase transparency of military activities.
- b. Reduce unnecessary military conflicts caused by misunderstanding, misjudgment and misinterpretation.
- c. Restrain military demonstration aiming at threatening, and make raiding more difficult.
- d. Promote cross-strait communication.
- e. Maintain regional peace and stability.

(2) Related Factors

- a. Political willingness: high-ranking policy-making officials and public opinions of both sides shall have willingness to a certain degree.
- b. Mutual benefit: mutual benefit and acquirable advantage are the motive power that contributes to an understanding.
- c. Supervisory mechanisms: after an agreement is signed, proper organizations or institutions are needed to supervise that both sides truly fulfill the agreement.
- d. Degree of compliance: if both sides participating in signing the agreement intentionally disobey or deliberately misinterpret the rules, the operation of the mechanisms will be impeded.

(3) International Opinions and Stances of Both Sides

- a. International opinions: as long as cross-strait peace can be maintained, basically, they "cautiously welcome" the establishment of the foresaid mechanisms.

- b. The ROC's stance: the government and private sectors have a "non-rejection" and "optimistic" attitude.
- c. The PRC's stance: internationally, the PRC government does not want to give the impression that they have tacitly recognized the ROC as a political entity; therefore, they still reject to establish "military mutual confidence mechanisms" with the ROC government.

3. Prospects of Establishing Military Mutual Confidence Mechanisms

(1) Principles

- a. Showing friendliness: promulgate the "National Defense Report" and "Annual Major Military Exercise Plans" to show our friendliness.
- b. No confined forms: adopt the approaches that are accepted by both sides. As long as conflicts caused by misunderstanding can be eliminated, our goals will be reached.
- c. No assumptions: set aside the "political" controversy and look for the chances of breaking the deadlock.
- d. Mutual respect: cast away the controversy of "central" and "local" governments, and build contact on the basis of mutual respect.

(2) Approaches

- a. Declarative measures: announce termination of the martial law, abolishment of suppressing the Communist rebellion, and the stance to peacefully settle disputes.
- b. Transparent measures: promulgate the National Defense Report and give notice of military exercises.
- c. Communicative measures: establish hotlines; promote cross-strait military academic exchanges and military officials' visit exchanges.
- d. Maritime security measures: sign a maritime security agreement, and establish a joint maritime rescue notification system.
- e. Restrictive measures: the number of soldiers stationed on the outlying islands is reduced, aircrafts and vessels do not cross the middle line of the Taiwan Strait, and targeting weapons are not deployed.

f. Investigative measures: encourage observer exchanges and set up early-warning stations.

(3) Implementation Actions

The planning and implementation can be divided into three phases: the near-, mid-, and long-term stages.

a. Near-term stage:

- (a) Make public the general information on national defense and gradually enhance the transparency in weaponry.
- (b) Implement the maritime humanity relief agreements.
- (c) Prudently choose the region and time for military exercises, and give advance notice of military movements and exercises.
- (d) Establish communication channels through the Straits Exchange Foundation (SEF) and the Association for Relations Across the Taiwan Strait (ARATS).
- (e) Establish more communication channels.

b. Mid-term stage:

- (a) Do not take military actions with the other side as a target.
- (b) Establish hotline mechanisms between cross-strait leaders.
- (c) Encourage visit exchanges between middle- and low-ranking military officials.
- (d) Encourage observer exchanges to observe military exercises and visit military bases of both sides.
- (e) Establish security dialogue mechanisms between high-ranking military officials, and regularly convene military consultative conferences.
- (f) Encourage visit exchanges of naval vessels.
- (g) Map out cross-strait demilitarized zones and build military buffer zones.
- (h) Encourage military data exchanges.
- (i) Implement investigative measures.

c. Long-term stage:

Terminate antagonistic situation, and sign cross-strait peace agreements.

III. Vision

In the future, the ROC Armed Forces will continuously enhance military interaction between friendly countries through military exchange and cooperation, so as to introduce brand-new military concepts to transform the mindset of the ROC Armed Forces and increase the overall combat strength. Furthermore, in line with overall national diplomatic efforts, the MND will duly promote visits and exchanges with friendly countries so as to pronounce the contribution made by the ROC Armed Forces to the regional security, create a positive national posture, and win the support for the Taiwan security from the international community.

2002
NATIONAL DEFENSE REPORT

Accomplishments and Prospects of National Defense Technology

To ensure victory in war, the ROC Armed Forces has followed the spirit of independence and autonomy in undertaking the R&D of various weapon systems that suit the needs of the national conditions. As a result, we have upgraded the defense technological capacity that helps prevent international circumstances from impacting our military buildup and combat readiness. After years of earnest efforts, the ROC Armed Forces has produced many weapons that are now in mass production or deployed, as a strong boost to the establishment of an indigenous national defense industry. Based on its strategic guidance and threats from enemy, the ROC Armed Forces in the future will take the initiative in the overall planning of information warfare, electronic warfare, command of air and sea, and anti-landing measures so as to build core military technological capacity for developing new weapon systems in the 21st century, ultimately securing victory in future hi-tech wars.

After the demise of Cold War, it has become a trend for many countries to transfer national defense technology to private sector for the economic development. In order to support national economic development, the MND has made an important policy of promoting dual-use technology. It will utilize the defense technology capacity built up by the CSIST over the years to assist industries in the R&D of high value-added products and obtaining competitive edges. In this regard, the MND has made great achievements over the years, with defense technology now widely adopted in industries and national competitiveness strongly enhanced.

I. Electronic Warfare System

Electronic warfare is an intangible war engaged between oneself and en-

emy within the electromagnetic wave field, with the purpose of damaging and destroying enemy's electronic equipment without affecting the normal functioning of one's own so as to create favorable conditions for victory. From the technological perspective, electronic warfare of the 21st century will employ equipment geared toward the characteristics of multi-frequency band, great degree of intelligence, automation, systematization, combined reconnaissance and interference functions, standardization, and modularization that will help to secure the electromagnetic frequency spectrum in the battlefield space.

In the planning of electronic warfare, the ROC Armed Forces, based on the objective of "establishing an electromagnetic shield in the Taiwan Strait and securing electromagnetic advantages", will follow the commanding guidelines of "integrated intelligence and information," "shielding first," and "rapid counter mechanisms," and resort to the measures of "combined surveillance and reconnaissance," "early warning" and "offensive defense." The ROC Armed Forces will then utilize their advantageous capability in electromagnetic warfare of "threatening, blockading and annihilating enemy" so as to secure the electromagnetic vantage point as well as obtain advantages for the general operations. Over the recent years, in accordance with such a planning concept, the ROC Armed Forces have been striving to construct an autonomous and offensive/defensive electromagnetic warfare system and to sustain electromagnetic warfare combat readiness, and have achieved many R&D objectives and related R&D accomplishments.

1. Build the Armed Forces' "Electronic Detection Net"

(1) Objectives: to integrate electronic intelligence and information systems, such as Strong Net system and Tacheng system to combine unmanned remote control aerial vehicles and underwater surveillance and reconnaissance systems; and to utilize management mechanisms of combined surveillance and reconnaissance, identification and frequency spectrum

to stay aware of enemy's electromagnetic frequency spectrum, so as to support general operations.

(2) Results

a. The following systems and projects have been accomplished: "hybrid electronic detection system," "laser weaponry early-warning system," "replacement and updating of the friend-or-foe identification equipment for in-service air fighters," "simulation analyses on early-warning system, tactical air defense radar system, and electronic counter counter-mechanism" and "upgrading naval surveillance and communications radar systems."

b. In order to fully control the electronic information and intelligence gathered by air, ground and underwater surveillance and reconnaissance systems as well as understand enemy's frequency spectrum, study on electromagnetic frequency spectrum management system is currently under way, in the hope of building a management mechanism.

2. Build the "Counter Electronic Shielding Net" of the ROC Armed Forces

(1) Objectives: to build a counter electronic shielding net capable of both active and passive defense. For the part of active defense, compound counter base stations will be constructed that utilize electromagnetic jamming to blockade and weaken the enemy's force. For the part of passive defense, there are several tasks: reinforce the counter-counter capability of weapons and carrying vehicles in order to intensify the ROC Armed Forces' combat capabilities in an electronically jammed environment; develop electromagnetic pulse (EMP) shielding capability to raise the survival rate in wartime; establish optical-fiber command and control system and frequency-hopping communication network in order to enhance the network security; and strengthen the stealth and shielding capabilities of important infrastructure and facilities to avoid attacks of weapons employing sophisticated homing technology such as infrared

imaging, laser, and GPS.

(2) Results

- a. The following systems have been accomplished: "naval on-board electronic warfare system," "air force standoff electronic counter-system and communications counter-system," "air force radar shielding system," "production and delivery of the army PRC-37A series introductory frequency-hopping communication system," "counter frequency-hopping communications electronic warfare," "infrared counter-system," and "VHF/UHF frequency-hopping radio communications system."
- b. The study on the EMP shielding technology is currently under way.

3. Create an Environment for the ROC Armed Forces' "Electronic Confrontation Simulation Testing, Evaluation, Exercises and Training"

(1) Objectives: to create a testing and training environment for the Armed Forces' electronic warfare "simulation testing and evaluation" and "live confrontation" to verify and assess the efficiency of weapon systems in electronic warfare; to develop tactics, strengthen combat skills, enhance personnel training, and bring the in-service and newly acquired weapons into full play, so as to improve the ROC Armed Forces' operation capabilities.

(2) Results

- a. The following projects have been accomplished: the "first-phase planning and construction of the ROC Armed Force's general electronic warfare testing and training grounds," "regular electronic warfare testing, exercises, and training for the ROC Armed Forces," "the ROC Armed Forces' annual Hankuang joint electronic warfare exercises," and "efficiency testing of the ROC Armed Forces' acquired electronic equipment and systems."
- b. The ROC Armed Forces will continue to push for the second-phase planning and construction of the ROC Armed Force's general electronic

warfare testing and training grounds.

II. Information Warfare System

Since the Persian Gulf War, countries around the world have begun to infuse information warfare into their operation pattern, operational organs, weapons & equipment and education & training. Facing this trend, the ROC Armed Forces must adopt the concepts of “information capability is combat capability” and “information advantage is the first vantage point in hi-tech wars,” and formulate strategies to secure victory in “information warfare” in the future.

To satisfy the needs of the ROC Armed Forces for information attacks and cope with the threats posed by PRC’s information warfare capabilities, the ROC Armed Forces under the concept of self-reliance and autonomy has been building up its offensive defensive capability of information warfare.

Related R&D focal points in information warfare of the ROC Armed Forces are as follows:

1. To ensure the security of the ROC Armed Forces’ information networks, the ROC Armed Forces must develop protection mechanisms for the gateways with external links of the ROC Armed Forces’ information networks, E-mail security codes, firewalls, internal verification management system, as well as security and protection testing system.

2. Develop information protection and communications security technology. Carry out the following projects in phases: the “R&D of the ROC Armed Forces’ communications security technology and equipment,” “establishment of preliminary protection technology for the defense combat status information system,” “real-time monitoring mechanism for the defense combat status information network and the establishment of preliminary technology for intelligent information flow controller,” and “development of related technology for the ROC Armed Forces’ computer emergency

response system” Reinforce the ROC Armed Forces’ information network security and anti-virus capability. Build up the capacity of hacking and cracking into enemy’s information system through Internet. Strengthen the electronic (magnetic) protection capability of radars, communications, missile fields, and command centers in order to effectively reduce enemy’s threats to our C⁴I as well as fully demonstrate our integrated operations capability with our C⁴ISR system.

III. Major Weapon Systems

Based on the defense guidance of “effective deterrence and resolute defense,” the ROC Armed Forces are engaged in the R&D of various weapon systems. From a long-term perspective, in view of the international and cross-strait circumstances, the ROC Armed Forces must build the capacity of adopting necessary and autonomous measures and actions in order to achieve the goal of effective deterrence and crippling enemy’s attempts. In terms of resolute defense, the ROC Armed Forces are engaged in independently developing various countermeasure weapon systems for air-command, sea-command and anti-landing, in order to meet the requirements of operations, strengthen the ROC Armed Forces’ overall combat capabilities, and ensure national security. In the meantime, the ROC Armed Forces aim to establish an integral logistics system as well as build up the capacity of autonomously producing key components and parts and securing key technology, in order to meet the objective of autonomous national defense.

1. Weaponry for Air Dominance

In view of the upgrade and diversification of the PRC’s aerial vehicles, the ROC Armed Forces are actively developing “multi-level” advanced air-defense missile systems for launch from aerial vehicles, ships and ground bases.

(1) Sky Bow I SAMs have been completely deployed and are responsible for the mission of medium-distance and mid- and low-altitude air defense.

The Sky Bow II SAMs, responsible for long-range and mid- and high-altitude air defense, have been deployed and put into service in batches according to schedules.

(2) Sky Sword I Short-Range AAMs finished serial production and have been deployed on IDF fighter Squadrons and are combat ready.

(3) Sky Sword II Medium-Range AAM, has beyond-visual range (BVR) and fire-and-forget capabilities, began serial production since 1997. These missiles are equipped on IDF fighters and combat ready.

(4) Surface-launched Sky Sword I SAM-"the mobile Sky Sword I SAM air defense missile system"-finished lead-in production in 2000 and is currently delivered to the air force for combat readiness testing and verification. Serial production is in preparation. It will gradually replace

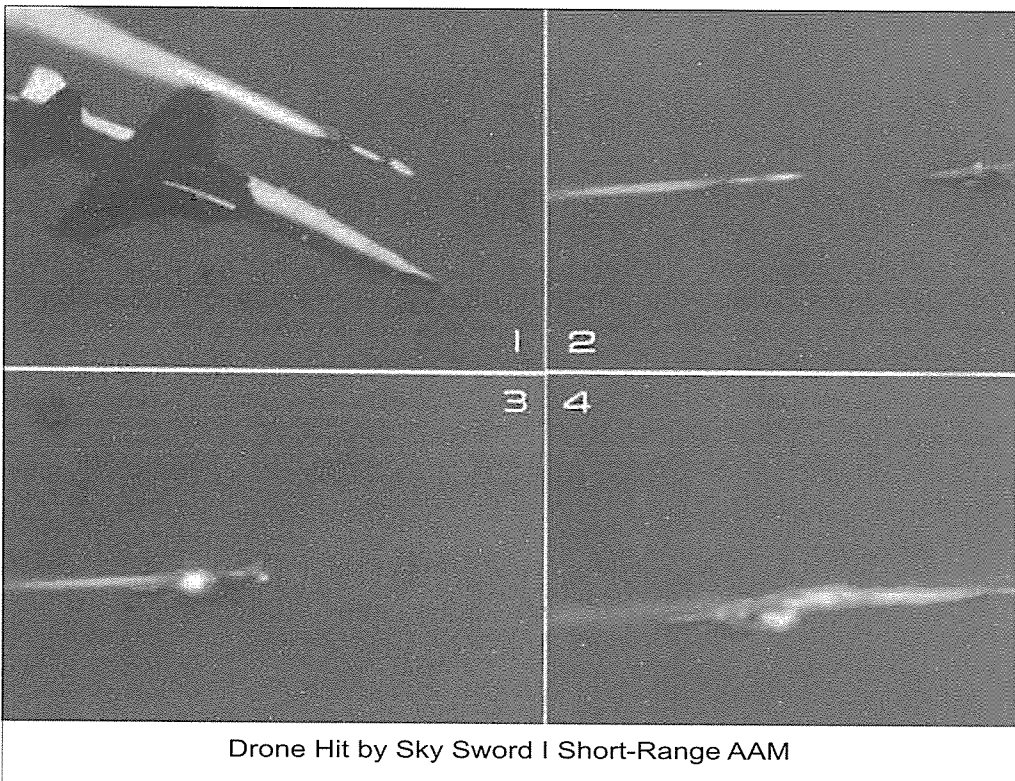

air defense artillery in phases so as to strengthen the air defense capability of the Army field units.

(5) Based on the requirements for the overall air defense, the ROC Armed Forces are upgrading IDF's combat capabilities and developing new types of air defense missile systems.

2. Weaponry for Naval Dominance

In order to cope with threats from surface and underwater weapons, the Armed Forces, with the line-up of second-generation vessels, will use warships and land-based positions as platforms and develop advanced combat systems, anti-ship missiles, and anti-submarine equipment.

(1) Hsiung Feng II anti-ship missiles have been deployed on Chengkung-Class and Lafayette-Class frigates and Wuching III destroyer. Besides, land-



Thunder 2000 Multiple Rocket Launcher System (MRLS)

based positions are combat ready and integrated with C⁴ systems to establish comprehensive capabilities of protection over the waters in the Taiwan Strait.

(2) The second-generation shipboard weapon systems have been installed in Chengkung-Class and Lafayette-Class frigates as scheduled. Besides, the navy has completed the acquirement of foreign weapons and the integration of electronic surveillance and reconnaissance equipments, new-type electronic warfare systems, and advanced C⁴ equipments, thus has efficiently promoted the navy's modern combat capabilities.

(3) In view of the threats from the PRC's submarines, the navy will continue and refine the R&D of underwater surveillance systems, including "sonar buoy," "ship-equipped sonar system," and "underwater surveillance and verification system," so as to strengthen the anti-submarine capabilities.

3. Weaponry for Anti-amphibious landing

In order to strengthen anti-landing capabilities, the new-generation "Thunder 2000" multiple rocket launcher system (MRLS) is developed to satisfy such needs. An important weapon for anti-amphibious landing, the Thunder 2000 MRLS has a long shooting range and far and wide impact areas. The prototype of Thunder 2000 MRLS was successfully tested and certified in preliminary operations evaluation in 2001. Serial production and deployment are in the planning.

IV. Key Know-how of National Defense Technology

Developing weapon systems is a large-scale and innovative task that requires huge amount of manpower and resources. Therefore, to reduce the funds and risks associated with weapon development and not to compromise combat readiness and armament, development plans are divided up and carried out in phases. In the preliminary stages, only a small amount of manpower and resources is devoted to the development of key technologi-

cal know-how and buildup of R&D capacity, aiming to achieve technological breakthroughs and accumulate fruitful results. Later on, based on the requirements of operations, further integrated developments can be initiated. Currently, the ROC Armed Forces' R&D of key technological know-know focuses on the following areas:

1. Scramjet Engine: scramjet engine is a new-generation missile propulsion system being developed enthusiastically by advanced countries. It is capable of reaching hypersonic speed and sustained cruising and will be used as the basis for the propulsion system of high-speed air defense missiles.

2. Small-thrust vector control liquid rocket: equipped with several small liquid fuel rockets which create sideways thrust, a missile's flying attitude and direction can be controlled so that its response time and hit rate can be improved. This type of rockets is a key technology for developing high-speed air defense missiles.

3. Low-altitude fire control radar prototype system: the research of the key technological know-how for low-altitude defensive fire control radar is conducted based on existing radar structure. The goal is to improve the air defense capabilities of important garrisons and field units.

4. Infrared reconnaissance and tracking system: in order to facilitate operations at night and under tumultuous weather conditions, the ROC Armed Forces starts to develop infrared reconnaissance and tracking system, which can be integrated with weapon systems to give fighter aircraft, naval vessels and armored vehicles the all-weather combat capabilities.

5. Protection against chemical warfare: in view of both the military and civilian needs for reconnaissance, fire fighting, rescue and education training, study must be carried on the technology and equipment of protection against chemical warfare.

6. Advanced warheads: in response to the development of the PRC's aerial vehicles, the ROC Armed Forces are building the capacity of designing powerful warhead shrapnel and conducting simulation analysis. The goal is to

intensify the piercing power of shrapnel to raise the efficiency of air defense weapon systems.

7. New-type RF circuit module of electronic artillery detonator: improve the RF circuit module of electronic artillery detonator to strengthen detonator's anti-jamming capability.

8. Imaging radar countermeasure technology: preliminary imaging radar countermeasure system has been accomplished that can be deployed in positions, vehicles and ships to enhance their capability of jamming or fooling enemy by false image as well as to counter the detection of satellite and vehicle-mounted radar.

9. Stealth technology: develop materials and applying techniques of stealth technology for air fighters. Reduce the new-generation fighter aircraft's surface areas that reflect back radar signals so as to improve the aircraft's mobility and reduce the chances of being detected.

10. UAV: in order to obtain real-time intelligence and quickly grasp the enemy's status, existing unmanned aerial vehicles (UAV) are further upgraded based on previous R&D experiences. In conjunction with tactics of maneuvering new-generation force, UAVs will be utilized to strengthen the ROC Armed Forces' C⁴ISR and intelligence-gathering capacities. Aside from military purposes, UAVs can also be integrated into the national disaster prevention system for a wide range of uses including reconnaissance missions over national boundaries, coastal surveillance, forest patrolling missions, environment surveillance, disaster relief, surveillance of overdevelopment and illegal development of land, etc.

V. Military-Civilian Dual-Use Technology

The CSIST is responsible for the R&D of large-scale weapon systems for the ROC Armed Forces and has accumulated abundant R&D experiences and technological know-how over the decades. Through national defense R&D system, the CSIST will carry out dual-use technology development plans by

combining existing manpower, equipment, know-how and its capabilities of integrating large engineering projects with the efforts from the government, industries and academia. The CSIST intends to transfer its leading-edge technology developed over the years to the private sector, in the hope of upgrading the industries' technological know-how and manufacturing capacities as well as strengthening the national competitiveness. The CSIST has had the following results:

1. Academic Cooperation

To satisfy the needs for developing key technological know-how, the CSIST has commissioned various universities in Taiwan to carry out research plans in five major categories of aviation technology, missile and rocket, electronic weapon system, chemical engineering, and material



Enhance Key Technologies to Establish a Self-reliance National Defense

technology. From July 2000 to now, a total of 91 academic cooperation plans have been carried out. These research plans will contribute to strengthening weapon efficiency and the ROC Armed Forces' weapon development technology. In addition, they will help to gradually build up the nation's capacity of manufacturing indigenous weapons, cultivate talents for developing defense technology, and establish a channel between military defense industries and private sector.

2. Special Technology Projects Entrusted by MOEA and Other Agencies

(1) In 2000, the CSIST was entrusted by the Ministry of Economic Affairs (MOEA) to carry out 13 special technology projects such as "the development of broadband wireless communications system," all of which have been completed as scheduled. In 2001, the CSIST was again entrusted by the MOEA to take on 12 special technology projects such as "the development of key system technology for the mechanical industry" as well as by the Energy Commission to carry out the "the development plan of high-efficiency catalyst burning power generation system." These projects are being carried out in accordance with the schedules.

(2) Of the subordinate plans under the MOEA's project of "the development of key system technology for the mechanical industry," the CSIST has worked on the "light-rail car system" plan. In this plan, the CSIST served as a system engineering coordinator and integrated the efforts of more than 30 local manufacturers to produce the "No. 1 Technology Project Light-Rail Car" that was unveiled to the public on March 2001. This is a tripartite winning strategy for the "industry, transportation, and operation." After the one-year testing period was completed in 2001, the light-rail car entered mass production. With the completion of the light-rail car system plan, it is expected that the basic capacity of locally designing, manufacturing and testing light-rail car can be built and that a suitable environment will be created for the light-rail car industry to grow.

3. Technological Transfer, Service and Promotion

(1) Executing the MOEA's technology projects, the CSIST has completed totally 129 cases of technological transfer in 2000. Within the same year, the CSIST facilitated 49 investment projects by manufacturers, with an estimated output value of up to NT\$9.4 billion.

(2) Through its research parks as a channel of communication, the CSIST provides technological service to both public and private sector. So far a total of 29 manufacturers have set up operations in the research parks and the CSIST has carried out 2581 cases of technological service, effectively providing technological know-how and services to the industries. The CSIST will continue its efforts in surveying the industries' needs, assisting them to grasp business opportunities, and ultimately contributing to the development of national economy.

(3) The CSIST has planned for the establishment of the "Wireless Communication Engineering Center." The Lungyuan Research Park of CSIST will be designated as the key base for the R&D of wireless communications technology, with the missions of assisting the development of military and civilian wireless communications products and facilitating wireless communications projects collaborated between the military and the private sector.

(4) To effectively utilize the capacity of local industries, the CSIST plans to commission the industries to develop or manufacture the parts and components, whole systems or subsystems needed for CSIST's R&D and production of weapon systems. The goal is to assist manufacturers in the private sector to become satellite factories for producing military products, build an integral division of labor system for the national defense industry, and to support development of a national defense industry. From July 2000 to now, the CSIST helped establish more than 20 satellite factories that produced totally 243 products.

(5) The CSIST has held the "ROC Armed Forces' Military Products Show 2000," with 261 products on display, from which civilian manufactures

could choose and express their interest in manufacturing.

4. Strategic Alliance

(1) The CSIST and Academia Sinica jointly inked the “memorandum for basic and innovative cooperation on applied sciences” on November 2000.

(2) On November 2000, the CSIST assisted the center to establish the “Valve Testing Center” in the CSIST’s Chingshan Research Park. The Valve Testing Center is currently under operation.

(3) The CSIST and Hardware Business Association of Kaohsiung City signed an agreement to form a strategic alliance on June 2001.

5. Attending Exhibitions Home and Abroad

(1) The CSIST attended the “Photonics Taipei 2000” sponsored by the Ministry of Economic Affairs.

(2) During July-August of 2000, the CSIST cooperated with the industrial promotion associations and industrial unions in various local cities and counties to present the “Exhibition of CSIST’s R&D Achievements & Island-wide Industrial Technology Promotion Seminar” in Taipei, Taichung, Kaohsiung, Hualien, and Kinmen. Many representatives from local industries were invited, with impressive results and more than 12,000 people attending the exhibition and seminar.

(3) The CSIST attended the “2000 Joint Awarding Ceremony for Industrial Technological Achievements” held by the MOEA. The CSIST won the “Excellence in the Whole Process Design Award” for its “five-year plan for the development of key system technology for the mechanical industry.” Besides, it was given the “Excellent Technology Award” for both the “plan of special chemical use-the technology for preparation of silicon oxide by wet-chemical methods and chemical mechanical polishing (CMP) slurry” and the “plan of civilian-use materials-the production of graphite materials used in the cathode of lithium-ion secondary batteries.”

(4) The CSIST attended "the 2000 Joint Exhibition of Technology Projects' Achievements" held by the MOEA, with 29 items featured such as the helmet-mounted display (HMD).

(5) In order to promote the export of military products and international cooperation, the CSIST attended the "Paris Air Show 2001" with models of four products: the indigenous "Thunder 2000 MRLS," "Vehicle-mounted Sky Sword I Missile," "Hsiung Feng II Missile," and "Sky Sword II Missile." The CSIST's presence attracted huge international attention.

(6) The CSIST attended the "2001 Taipei Aerospace Technology Exhibition," demonstrating great technology capacity with 12 indigenous products on display, such as the "1:2 model of the Chunghsiang No.2 Unmanned Aircraft" and "full-scale model of the Hsiung Feng II Missile."

6. Vision

In the future, the ROC Armed Forces will cultivate sufficient human resources, and focus its attention on major national technologies as well as integration of development and system of key defense technologies. Besides, the fundamental research on electronics, information and material will be actively pursued so as to strengthen fundamental defense technology base. Besides, the MND will, in line with national technology development mechanism and industrial development strategies, adopt ways like technology transfer or exchange to continuously promote cooperation in military-civilian dual-use technology spheres so as to create a "win-win" result in which mutual benefits between defense and civil industries have been achieved.

Chapter 8

Human Rights Protection for Servicemen

I. Purposes

Servicemen are also citizens of the country and therefore are entitled to basic human rights, such as personal freedom, the right of existence, the right to work, the right of property, the right of lodging complaint and instituting legal proceedings, and the right of political participation as defined by the Constitution. As a result, the MND has set up a complaint mechanism for enlisted men, established the Council for Protection of Legal Rights and Privileges among Military Personnel, revised the Criminal Law for the Army, the Navy and the Air Force, and amended the Court-Martial Jurisdiction Law in a bid to enhance human right protection.

II. Revision of the Criminal Law for the Army, Navy, and Air Force

As the society has become more pluralistic, the principles of penal code have also evolved with time. To protect the human rights of servicemen and maintain high morale in the uniformed services, the MND has initiated the amendment of the Criminal Law for the Army, Navy and Air Force since 1991. The amendment was passed by the Legislature on 27th September 2001 and promulgated on 2nd October of the same year.

The amendment has fundamentally changed the structure and content of the original law to further reflect contemporary thoughts of criminal code and the development of the country by taking into consideration of the needs for military deployment and national security. The new law promises to protect the basic human rights of the ranks and files and new recruits, specifies the rights that servicemen are entitled to, insures that the ranks and files can legally and legitimately express their opinions and claim their rights, guarantees a smooth complaint mechanism, and is designed to boost soli-

clarity and harmony of the military. In addition, the new law also narrows the applicability of mandatory death penalty (to include only defiance of orders and false reporting during wartime) and alleviates the punishment for certain crimes. As a result, servicemen's human rights are fully protected, and discipline in the army is maintained. This in turn will enhance national security. The revision of the Criminal Law for the Army, Navy and Air Force is identified by the Non-Governmental Judicial Reform Fund as one of the most important events in Taiwan for human rights promotion in 2001.

III. Revision of the Court-Martial Jurisdiction Law

The Amendment of the Court-Martial Jurisdiction Law has been effective since October 3, 1999, with the establishment of supreme, superior and district military courts and prosecution bureaus. Under the new regulations, senior officials no longer have the right to ratify or renew a verdict, nor shall they decide the composition of court staff. To bring the court martial system one step closer to meet the requirements for human rights protection, the new provisions stipulate that defendant may appoint defense counsel during investigation.

Moreover, in a bid to reduce discrepancies between military and criminal prosecution, the MND amended the Court-Martial Jurisdiction Law to give the right of issuing military search warrant to military courts. The amendment further states that in the case that a search warrant or distress warrant is revoked, impounded articles shall not be presented in court as evidence so as to protect human rights and avoid abuse of search warrants. Intended to provide service personnel with the same quality of legal protection as citizens, the amendment was passed by the Legislature on January 8, 2002 and promulgated on February 1.

IV. Protecting Rights for Servicemen

The MND, along with the general headquarters of each service, established the Council for Protection of Legal Rights and Privileges among Military Personnel on March 16, 1999 to cope with cases of complaint, grievance, accusation, and legal right issues brought up by military personnel and their dependents. According to the 19th article of the National Defense Law, which stipulates that the MND should establish the Council for Protection of Legal Rights and Privileges among Military Personnel, the MND decided that the Council would be a permanent body. The Council is expected to provide a management system and a specialized unit to handle issues related to the interests and rights of servicemen and their dependents. By engaging professionals as council members and counselors and enhancing transparency of investigation process, the Council will serve to protect the interests and rights of servicemen in an objective and impartial manner.

Before the establishment of the Council, the establishment processes had been carefully drafted, studied, reviewed, and revised by the Legal Department, the Manpower Department, Bureau of Military Jurisdiction, before they were approved on October 31, 2001. The aforementioned establishment processes was promulgated on March 1, 2002.

V. Vision

While aspiring to protect the interests and rights of servicemen, the MND is also dedicated to innovating the military law system. On the one hand, the ministry strives to establish modern regulations that meet servicemen's needs, equip enlisted men with legal knowledge, and carry out innovative management methods with an aim to enhance leadership among cadre members and boost solidarity in the military. On the other hand, the ministry expects to build up an armed force where law and discipline are respected.

2002
NATIONAL DEFENSE REPORT

Chapter 9

Insurance, Welfare, and Medical Care

Taking good care of servicemen's life, struggling for their welfare and sending medical care are the indicators for the MND's devotion to promote servicemen's life quality and working environment with a view to making soldiers be loyal to their job without worrying about their life so as to focus attention on their duties and to maintain a positive image for servicemen.

I. Insurance

The MND launched the group casualty insurance for the active duty on July 1, 1998 with the highest compensation up to NT\$ 2 million in a bid to extend the care for the military servicemen and their families. Since then, the MND has allocated its insurance budget based on the principle of "high protection, low fee."

Considering the contribution of those who are dead or injured during regular service tasks, and the danger of getting heatstroke, shock, sudden death, heart failure, bites by bugs or snakes, faint, and stroke for military personnel during drills or rescue works, the MND decided to expand the policy of the group insurance from January 1, 2001 onwards to include coverage of life insurance. The renewed insurance policy increases the compensation for accidental death on duty to NT\$ 3.5 million. Those who incur any of the aforementioned accidents can also claim compensation according to the new policy.

Meanwhile, from January 1, 1991, flight crew and ammunition staffs are insured against accidents on duty with compensation up to NT\$ 10 million.

II. Welfare

1. General Welfare

In order to realize "three assurances" policy, the MND has adopted the

following measures, under the consideration given to both mental and physical conditions, to take good care of servicemen's welfare:

(1) Commodity supply

Currently 32 Regional Commodity Supply Centers and 165 post exchanges are there to provide servicemen and their dependents with daily necessities at costs 20% lower than average market price. The commodities available are as many as 4,839 items.

(2) Supply of accessory food

In order to offer good meal service, there are 32 supply points established in the military to distribute accessory food at costs 20% lower than average market price. The food available at these supply points are as many as 1,378 items. Accessory food is also shipped to offshore islands to ensure the food supply on these islands is of fine quality and hygienic. Besides, the MND has set up 21 delivery lines to transport these foods to 93 isolated military units, and there are about 6,000 servicemen benefited from this accordingly.

(3) Creating fringe benefits for military personnel

Being the funding source of the ROC Armed Forces Production and Operating Fund, sales from the supply centers and post exchanges are used to create fringe benefits for servicemen. One of the functions the Fund is designed with is to support leisure activities within the military.

2. Consortium Corporation of the ROC Armed Forces and Dependents Support Foundation

With an aim to extend benefits for servicemen who are killed or wounded in action so as to create and maintain readiness and morale in the military and provide better care to families of servicemen, the MND established Consortium Corporation of the ROC Armed Forces and Dependents Support Foundation on April 1998. The foundation uses its fund interests to

assist servicemen or military academy cadets who are killed or wounded in action and their families.

Since its inception, the foundation has received universal support from all parties and has raised NT\$ 460 million of funds. It has started to award compensation benefits to servicemen who are killed or wounded in action and their dependents since August 7, 1999. Compensation for those who are dead due to dangerous duty is up to NT\$1.5 million each, and that for the injured and disabled ranges between NT\$ 300,000 and NT\$ 1.5 million each. Compensation for those who are dead during regular service tasks is NT\$ 500,000 each, and that for the injured and disabled ranges between NT\$ 150,000 and NT\$ 500,000 each. The foundation will gradually increase the compensation as its interests accrue with the expansion of funds.

The foundation will continue to raise funds from the society with the target amount of NT\$6 billion and will keep on distributing compensation benefits so as to provide the best care to the enlisted men and women and their families.

3. Service for Military Personnel

As part of its efforts to intensify the care for the military personnel, the MND initiates an emergency relief scheme that aims to provide financial support to servicemen in need. Entitled to the emergency relief are those who are killed or wounded in action, those who or whose families face difficulties in supporting their lives due to serious accidents, those who have proof of hospitalization or taking medical treatment for any injuries or diseases, those who have proof that their parents, spouses, and children are hospitalized for any injuries or diseases, those who have proof that their parents, spouses, and children are dead, those who have proof that they themselves or their spouses are in labor or have dystocia, and those who are affirmed by their supervisors as sick. By offering condolence and support to servicemen in trouble before they seek for it, the MND expects

to stimulate military personnel's commitment to the Armed Forces.

III. Medical Care

1. Medical Care for Servicemen

In the light of the scarcity of medical resources available to military personnel, the MND has worked with the Department of Health under the Executive Yuan on revising the National Health Insurance Law in order to put servicemen under the coverage of the National Health Insurance (NHI). The amendments passed in the Legislature state that the country's military personnel should join the NHI scheme on February 1, 2002, enabling them to share the nation's medical resources with civilians. On the other hand, the MND vows to beef up medical care for servicemen by announcing to provide medical treatment subsidies for servicemen who are injured whether on or off duty.

Currently, voluntary servicemen, civilian employees and their dependants are insured as insurants of category 1 and 4 category under the NHI scheme as the MND is responsible for 60% of their premium. As for active servicemen, military academy cadets, and dependents of servicemen who have died, they are under category 4 with the MND totally paying the premium. Currently, 450,000 enlisted men have joined the NHI, and the MND's expenses on health insurance amount to NT\$ 4.3 billion annually. Besides, in the light of making servicemen have free (no self-payment) medical service in military hospitals and dispensaries, the MND enacted "Temporary Regulations for Preference of Medical Service for Servicemen and Cadets" and "Regulations for Subsidies for Servicemen and Cadets Wounded in Action" in February 2002. As a result, when servicemen and cadets need medical service no matter in military or civil hospitals, they will have preference of no self-payment so as to ensure the servicemen's rights

2. Basic Level Emergency Medical Care

In consideration of streamlining conditions and changes in force structure, since 1998 the MND has been actively promoting basic medical training for basic level units so as to improve the quality of medical service in basic level units. Currently, there are 1,838 eligible medics out of this training. At the same time, in concert with the Fire Department and Emergency Medical Service Commission, the MND has also held mid-level medical trainings for those medics dispatched to respective ambulance, and there are 86 eligible medics in this category.

Furthermore, in August 2000, the MND has offered training courses for naval surgeons, which are divided into two phases: pre-job and advanced CPR training phase, and intern phase. After receiving such courses, these surgeons will obtain certificate of advanced CPR. In addition, the MND has also held advanced medical training courses for regular medical sergeants. These courses are divided into two phases: basic and mid levels medical training phase, and intern phase. After receiving such courses, these medical sergeants will obtain certificates of basic and mid levels medical services so as to enhance their medical skills.

3. The Development of Military Medicine

Aviation medicine and diving medicine, which are closely knitted with the enhancement of combat strength in the frontline, are specialized medical disciplines within the defense system. To maintain the health of aerial and naval personnel is an irreplaceable mission of the people who studied aviation and diving medicines. Annual aviation examinations for aircrews and flight surgeons are all conducted by professional and seasoned flight surgeons. Besides, the MND has also conducted professional physical examination for aircrews for aviation units in the ROC Armed Forces in order to make sure that they physically fit in flight missions so as to maintain flight safety.

At the same time, the “Regulations of Flight Surgeon of the ROC Armed Forces” has been revised to meet special needs during the conversion of the new generation fighters. Flight medication and aviation physical examinations are all revamped in this regard so as to facilitate the realistic flight medical operations. Besides, research on diving physics and improvement on pressurized cabin facilities have also given sound protection of military personnel involved in the relevant missions.

IV. Vision

1. Insurance: The ROC Armed Forces will be responsible for dealing with insurance policy for all servicemen so as to take good care of them and their dependents. Based on the principle of “high protection, low fee,” the relevant military units will submit their annual budgetary plan in this regard; furthermore, the insurance policy will be preferential for those who killed or wounded in action so as to help their families to overcome their sufferings and to show the MND’s respect to their contributions
2. Welfare: Welfare service needs to be promoted continuously so as to satisfy the servicemen and their dependents. The MND will do its best to offer low-cost and high quality commodities to increase surplus for servicemen, and actively offer condolences and comfort services for those personnel in distress so as to win their approval and support.
3. Medical service: In line with Refining Program of the ROC Armed Forces, the MND military will adopt enterprise management concepts to merge hospitals and dispensaries so as to offer effective and instant medical service for servicemen and civilian. Besides, the integrated medical information system will established to broaden medical sphere, offering long distance medical service and education; a medical strategic alliance of the ROC Armed Forces will also be established to gradually independent from relying on defense budget, and the medical units under this alliance shall have to rely on its own resources to maintain operational.

Rebuilding of Military Dependent Quarters

I. Purpose

The ultimate goal of rebuilding dependent quarters is to create a “win-win-win” situation for the government, the public, and military dependents by renovating city planning, increasing tax income and solving land disputes for local governments, creating job opportunities, and reviving the overall economy. The rebuilding plan will not increase government expenditure and citizens’ tax forms, as it is not listed on the central government’s annual budget. In addition, the rebuilding fund will be used to support low-income families, military personnel and their dependents by providing low-interest rate mortgages.

II. Policy

At present, rebuilding of military dependent quarters is carried out in accordance with two systems, namely the “new system” and the “old system.” The old system refers to the “Operation Guidance for the Tentative Rebuilding Plan for Deteriorated Military Dependents Quarters,” whereas the new system means the “Regulations of Rebuilding Deteriorated Military Dependent Quarters.” The MND also convened the “Committee for Promotion of Rebuilding Military Dependent Quarters” and a fund management committee to insure that the rebuilding fund is properly used. Please refer to Fig. 6-4 for detail.

Plans to rebuild quarters in old system that need refurbishments have already authorized by the Executive Yuan, and those quarters will be reconstructed with joint efforts from local governments and the Military Dependents Housing Cooperative Society. In a bid to accelerate the rebuilding process, the MND resorts to the private sector for capital and manpower by adopting four measures: package, co-building, united bid, and comprehen-

Figure 6-4

Organization Charts of Authorities for Rebuilding Military Dependents' Quarters

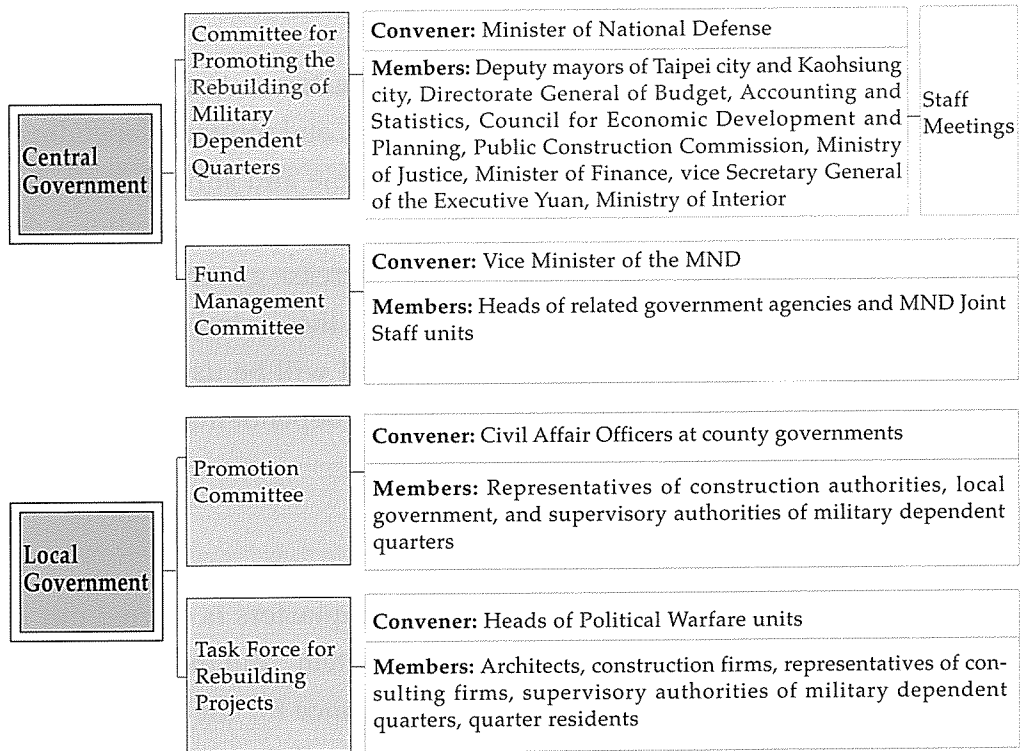

sive bid. Moreover, in accordance with national overall residence construction policy and "Plan for Funds of Rebuilding Old quarters of the Armed Forces" authorized by the Executive Yuan in May 17, 2002, the MND is committed to assisting quarter residents in acquiring public housing or existing homes as a way to boost the local real estate market. According to schedule, relevant planning tasks shall be finished by 2003. The overall rebuilding project is expected to be complete by 2005. Fig. 6-5 illustrates the rebuilding policy, goals and implementation methods.

III. Implementation Status

Figure 6-5 Rebuilding Plan of Military Dependents' Quarters

Rebuilding	MND holds bid measures	Co-building	Houses completed will be split between the MND and construction firms	
		Package	Construction fees will be partly compensated by accepting idle lands	
	Entrusting the Construction and Planning Administration and local governments	Comprehensive bid	Including construction, power/water supply system, and landscape design	
		United bid	Including architecture design, construction, power/water supply system, and landscape design	
Rebuilding policy	Assisting quarter dependents acquire public housing or private housing			
	Assisting quarter dependents to move out			
	Principle: no excess houses; rebuild the larger quarters and relocate the smaller quarters; rebuilding takes precedence over relocation			
Goals	Period	1997-2005 (Project completed and bidding within 9 fiscal years.)		
	Target number of quarters	71,812houses in 102 quarters (40 quarters for mid-/low-income families)		
	Budget	Limit	NT\$516.7 million	
		Source	Gains from disposing land	

1. By the old system

In order to realize the government’s policy to take good care of military dependents and retirees and improve their living conditions, since 1980, the MND has been undertaking rebuilding programs for old military quarters in conjunction with local governments and commissioned the Military Dependents Housing Cooperative Society. Currently, there are 73 old quarters authorized by the Executive Yuan to be revamped. 30 of them have been rebuilt, and the rebuilding operations for 17 (13 quarters are collaborated with local governments to revamp, 4 of them will be rebuilt by the military, totaling 10,802 households relocated) of them are still underway. Meanwhile, there are 18 quarters (4 quarters are collaborated with local governments to revamp, 14 of them will be rebuilt by the military, totaling 2,978 households relocated) waiting to be revamped.

2. By the new system

The overall rebuilding plan involves the expansion and relocation of old quarters and assistance for quarter residents to secure loans necessary for

acquisition of public housing or private housing. The project started in 1997 and is expected to complete in 2005 with the establishment of 102 residential quarters, totaling 71,812 households relocated. The rebuilding plan will be financed by disposal gains from land lots allocated to the rebuilding plan. Gains from Disposing lands are estimated to be NT\$516.7 billion and the expenses needed are expected to be NT\$516.6 billion.

Amongst the 102 quarters to be rebuilt, one has completed, 53 are still under construction, and 49 are waiting for construction licenses. The MND will stop construction of military dependent quarters from 2005. However, the ministry will provide officers with mortgage loans and official residences for officers.

On the releasing of land for public facilities and land rezoning, Chingcheng Quarter and Maoyi Quarter in Hsinchu and Haiguang 2nd Quarter in Kaohsiung have been reestablished as residence districts or commercial districts. A total of 72 hectares of land has been transformed from dependent quarters into residence or commercial districts. Meanwhile, 174 land lots with total area of 26.7 hectares are released to local governments for construction of public facilities.

3. Housing Subsidies

To encourage purchase of public housing or private housing on the estate market, the Regulation of Rebuilding Deteriorated Quarters for Military Dependents stipulates that quarter residents, servicemen on active duty, civilian employees, voluntary forces and retirees, public servants, policemen, alternative military servicemen, and military officer trainees are eligible for preferential mortgages. Currently 1,072 houses from nine rebuilt quarters are available for purchase. In the meantime, 2,584 families in 16 quarters have received assistance in purchasing public housing whereas 147 families have purchased private housing with help from the MND.



Rebuilding of Military Dependent Quarters

To improve preferential mortgages for servicemen, credits extended to military personnel at all levels were expanded in 1994 (NT\$ 2.2 million for lieutenant generals and major generals, NT\$2 million for colonels, NT\$ 1.8 million for lieutenants and below (including chief petty officers), and NT\$ 1.5 million for NCOs). Up to 2,000 applications are approved each year. As of 2000, 24,691 houses have been purchased via the preferential mortgages, with total credit exposure amounting to NT\$ 37.4 billion.

On the other hand, the Service Center for Rebuilding of Deteriorated Military Dependent Quarters has received 457 applications by telephone and 512 applications in written forms in a year. The total 978 applications have been filed and replied in either spoken or written form.

IV. Vision

In order to carry out the “three assurances policy,” aimed at guarantee-

ing safety for the forces, giving servicemen a steady life, and providing military dependents with better living standards, the MND is committed to enhance preferential mortgages extended to servicemen and revamp barracks and official residences for military officers in hopes to provide better ac-



Vista of the Da-peng Dependent Buildings in Hsin-tien, Taipei County

commodation for servicemen who are stationed afar, even though it will stop rebuilding dependent quarters in the future. It is expected that efforts in this regard may relieve servicemen's homesick, focus their attention in their respective duties so as to realize the policies of the government and the military to take good care of the servicemen.

PART SEVEN
ROC ARMED FORCES AND SOCIETY

Summary

1. In view of the implementation of national defense affairs, the MND has been constantly striving for the transparentization of national defense affairs, and doing its best to handle military news with an active attitude to communicate and coordinate with the parties involved. Information regarding defense policies, combat readiness and military trainings, motions of the PLA, rights of servicemen and forces management, etc, will all be properly issued to the public.
2. By the implementation of concrete measures like “reducing the scope of military secrets,” “compensation for the property damages and civilian casualties caused by the services,” and duly handling of “people’s appeals” and “national compensation,” the ROC Armed Forces vows to protect the rights of the people. In response to the global trend of zero-mine, the ROC Armed Forces has examined and surveyed all the minefields that have no tactical value or already been released control for purposes of mine clearance.
3. Generally speaking, the Military Police (MP) is responsible for handling military-related affairs on its role to maintain social security. The MP will still join efforts with security, intelligence, and investigation agencies or organizations so as to purify its internal mechanism, prevent and investigate civil criminal cases, and eliminate public hazards that may threaten the social security.
4. When the people suffer major disasters caused by typhoons, oil pollution, forest fires, air crashes, etc, the ROC Armed Forces, based on “the Calamity Prevention and Rescue Law,” will actively dispatch its forces to assist in disaster relief and rescue efforts. The ROC Armed Forces wholeheartedly devotes all its strength to help in such efforts so as to protect the nation and its people.
5. If an outbreak of epidemic occurs in any region, the ROC Armed Forces will execute investigation and management procedures of emergency epidemic situation according to relevant regulations in the hope of having

the epidemic situation under control and preventing the epidemic from spreading. Besides, the responsible military medical units will conduct operations like quarantine and treatment, distribution of preventive medicine and cleaning up the environment, etc.

6. The military units will hold family reunions and other social activities for families of conscripts to establish a benign interaction with them, and relieve their doubts by making them realize the actual status of their children in the military, so as to further establish cohesion between the conscripts and the their respective units.

Chapter 1

The Transparentization of National Defense Affairs

I. Objectives

For a democratic nation, people are endowed with the right to oversee defense affairs. As a result, the MND has not only been constantly striving for the transparentization of defense affairs by coordinating closely with other government agencies and organizations representing the popular opinion, but also openly delivering explanations on defense policies to make the general public realize the implementation status of the MND's undertaking. In order to respect the people's right to know, the MND will

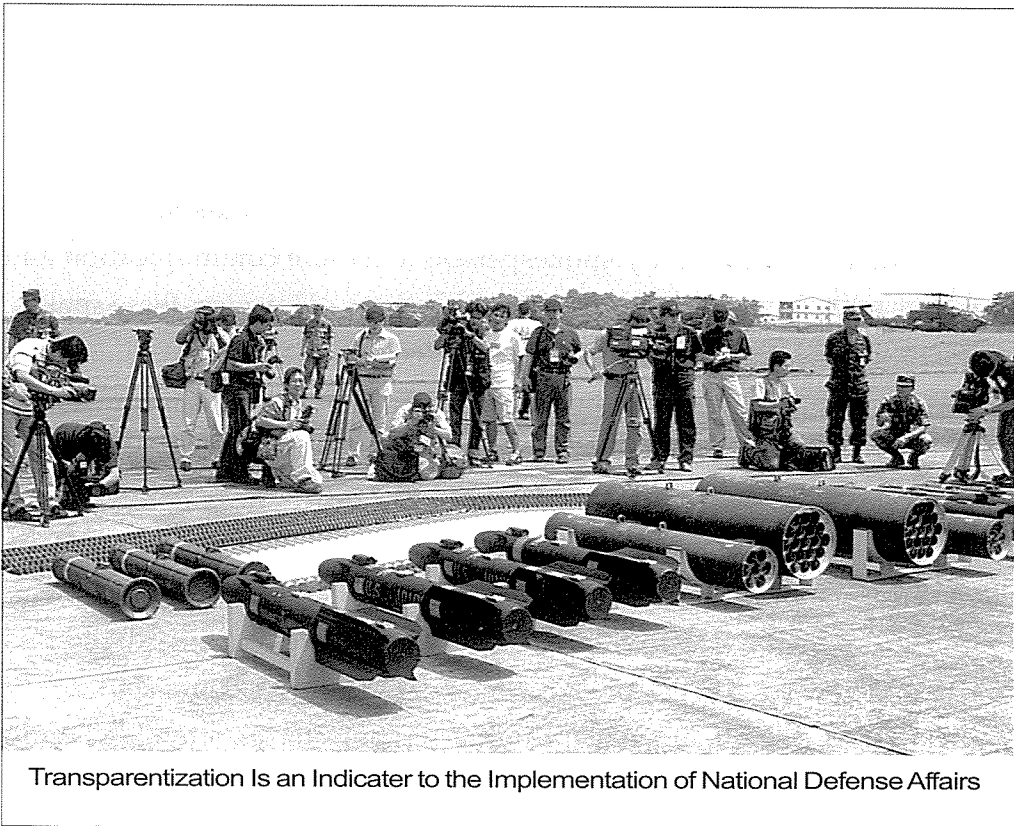

continuously dedicate to the transparentization of defense affairs so as to win their approval and support and foster the consensus on the all-out defense policy among them.

II. Timely Explanation of Policies

In light of contemporary trends in transparentization, the MND will actively deliver timely explanations about major policies of the ROC Armed Forces so as to lead the news media to broadcast the actual facets in the military. Therefore, the general public's understanding on major defense policies can be enhanced. Relevant methods adopted by the MND in this regard are as follows:

1. Observing spokesperson system: The Military Spokesperson Office (MSO) is responsible for delivering explanations on sensitive issues, such as major defense policies, status of combat readiness and training, and the movement of the PLA. On the premise of maintaining national interests and security, the MSO will adequately clarify doubts and confusion in defense affairs faced by the public in order to win their approval. Besides, the MND has authorized units above army corps level dispatch specific personnel to act as military spokesperson to handle communication and contacts with the public, and inquiries from them. However, these spokespersons are not permitted to deliver sensitive information regarding forces deployment, military procurement, international military exchange, sources of intelligence, R&D in weapon systems, and cross-Strait issues.

2. Convening regular press conference: The regular press conference is presided by the Military Spokeperson on every Tuesday morning to deliver information or respond to inquiries from the media. Relevant personnel from the MND and the GHQs of each service will also attend that session. There are total 84 press conferences held in 2000 and 2001.

3. Holding defense lectures for military reporters: To strengthen military reporters' perception of defense affairs, the MND has been holding defense lecture quarterly. The topics in the past include "the impact of

Kosovo war on the future warfare," "the trend of cross-Strait electronic and information warfare," "the recent development of the PRC's ballistic missile and the ROC's countermeasures," "the role of the ROC's servicemen in all-out defense," "the direction of the PRC's military establishment and the analysis on the PLA's upgrade in military strength," "Science, Technology and the Revolution in Military Affair," etc. Through these lectures to promote mutual understanding, the media reporters will thus develop the correct conception of national defense so as to further dedicate themselves to supporting defense policies.

4. Inviting media reporters to visit the ROC Armed Forces: In 2000 and 2001, the MND has arranged 68 tours to military units for media executives and military reporters. Such tours included visits to "the Honorary Model Companies and Groups of the Services," "Hankuang No.16 and 17 Live-fire Exercise," "the Commissioning Ceremonies of the IDF, Mirage and F-16 Wings," "the Reinforced Military Readiness Exercises during the Chinese New Year," "the Navy Hsu-hai Drill," "the Army Hsiung-shih Drill," "the Army Academy Pu-kuang Drill" and "the Army Wu-han Drill of Ku-Kuan Special Forces," etc. Through these tours and broadcasts by news media, it's believed that the public will be more familiar with the ROC's overall military readiness.

In addition, the MND has attached news reports, defense information of public interest to the website of the MND (www.mnd.gov.tw) for the people to inquire. Furthermore, the MND publishes various communiques and periodicals, and offers e-news through e-mail service so as to satisfy the people's right to know.

III. Active Communication and Coordination

Proper management of the aftermath of news equals the risk management. Regarding all the false and negative reports or news that would defame the ROC Armed Forces, the MND will follow its contingent procedures to ac-



Timely Offer Military Information to Establish Consensus on All-out Defense

tively communicate and coordinate the parties involved. The principles of such procedures are as follows:

1. "Giving explanations actively, instantly and clearly:" In order to provide a timely response, military units involved have to find out the facts about such contingencies by 4 hours, give proper response to news media by 8 hours in order to eliminate hearsays and false reports and maintain the upright image of the ROC Armed Forces.

2. "Keeping a humble and sincere attitude:" The units involved are demanded to keep a humble and sincere attitude to handle such contingencies so as to remove the people's doubts and unnecessary imagination or further harms on the parties involved. Records or reports of honorary actions of units or personnel will be actively released to the public.

IV. Vision



Open Visits to the Military for People to Witness Current Readiness Status

After the enactment of the “National Defense Law and the Organization Law of the Ministry of National Defense,” the ROC Armed Forces will adopt “professionalization,” “technologicalization,” “legalization,” and “functionalization” as its guidelines. Therefore, the MND will actively deal with communication and coordination with government agencies and private sector, and properly handle military news or reports to deliver information regarding rights of servicemen, forces management, and other message of public interest so as to foster the consensus on the all-out defense policy. Besides, the MND will continuously coordinate with government agencies, and maintain a sound interaction between each other so as to maintain the positive image of the ROC Armed Forces.

Protecting the Rights of the People

I. Objectives

On the basis of the protection of military secrets and national security, the MND has formulated several concrete measures, such as “classification scope of defense secrets,” “compensation to human casualties caused by military service,” “management of the people’s appeals,” “regulations for applying for national compensation,” and “elimination of obsolete minefields,” etc, to justly and objectively protect the rights of the people.

II. Concrete Policies and Measures

1. Reducing the Scope of Military Secrets

(1). Clear demarcating of military secrets and national defense secrets
Pusuant to Article 78 of the amendment of the “Criminal Laws of the Army, Navy and Air Force,” the MND has planned to draft “Demarcation Guidelines of Category and Scope of the Military Secrets and the National Defense Secrets” to clear the doubts regarding the demarcation of these two kinds. The MND has thus established a special committee consisting of scholars and experts to examine relevant proposals and drafts. Based on rationality and necessity, the special committee has proposed “Demarcation Guidelines of Category and Scope of the Military Secrets and the National Defense Secrets” through clear, well-defined and law-abiding ways to perfect the legal mechanism to protect secrets. The said guidelines will be promulgated in mid-2002.

(2). Establishing “the Deliberative Committee on the Betrayals of National Defense Secrets, MND”

In order to set up the mechanism to secure national defense secrets, the MND has founded “the Deliberative Committee on the Betrayals of National Defense Secrets” in May 2001, pursuant to Article 20, the

Organization Law of the Ministry of National Defense. This committee contains of legislators of the National Defense Committee in Legislative Yuan, professionals and experts from fields of jurisprudence and journalism to take part in the review process of defense secrets in order to draw convincing and objective conclusions to facilitate judiciary and investigation agencies to deal with incidents of betrayal of secrets.

2. Easing the Restrictions on Military Control Zones, No Construction Zones and Limited Construction Zones

(1) Purposes

The purposes to set up a military control zones are to ensure the functions of weapons and equipment, secure mountain and maritime area, and prevent from smuggling and illegal immigration so as to safeguard the nation's political and economical development. However, in light of limited land resources and potential impacts to local development, the MND, in accordance with its adjustment in deployment of forces, has actively downsized or eased the restriction scale of those improper or obsolete military control zone to let government or private sector make the best of land resources.

(2) Policy guidelines

- a. Based on the consideration of national economical development, local development and the people's livelihood, eliminate the unnecessary military control zones while upholding the principle of bilaterally maintaining the national defense and the people's livelihood.
- b. Based on the minimum military demands, complete the revision of "the Regulations on No Construction Zones and Limited Construction Zones," and adjust such zones in stages accordingly.
- c. Based on overall functions of garrisons in wartime, assess their existing values in programmatic ways.
- d. In accordance with the planned merger or downsizing of barracks or

strongpoints, eliminate major military control zones, which are no longer in need or use.

e. Conduct reviews on removing dangerous fuel reserves and ammunition storages to slight mountain slope areas, or adopting relocation ways and safety measures to minimize the the possible damage to the neighboring areas and downsize their respective restriction scale.

(3). The implementation status:

Downsized or eliminated military garrisons and military control zones of the ROC Armed Forces over past three years are as follows:

a. Garrisons:

i. Eliminated: 2 garrisons including one at Da-chu and the other at Shao-chu, Lien-Chan County.

ii. Downsized: 2 garrisons including one at Mountain Tai-wu, Quemoy and the other at Ta-chi, Taipei.

iii. Altered status as military control zones: totally 10 sites, including which at Ho-ping Island in Keelung, at Wai-an of West Reed and Hujung Reef in Penghu, at Shao-kwei Mountain in Kaoshiung City, at Litow Mountain in Hsin-chu County, at 48 (Szu-ba) Highland in Hualien, in Partas Island, in Spratly Island, at Lian-dao and at Kao-den.

b. Major military control zones:

i. Eliminated: totally 12 sites, including 3 in Taipei County, 3 in Tao-yaun County, 2 in Chang-hwa County, 2 in Jia-yi County, and 2 in I-lan County.

ii. Downsized: totally 93 sites in Taiwan, Penghu, Quemoy or Matsu areas.

3. The Compensation for the Property Damages and civilian Casualties Caused by the Services

(1) In order to compensate civilian casualties caused by the services from 1949 to July 1st, 1981, or before the enactment of the "National Compensation Law" (extension allowed to November 7, 1992 for those from Quemoy and Matsu), the MND has stipulated the "Compensation for the

Property Damage, Casualties of the People Caused by the Services" that took effect on December 1st, 1999.

(2) Up to December 2001, the Compensation Committee has dealt with 1,210 cases through regular deliberative meetings. Even with the retroactive effect of the enactment, however, since most of the applicants could hardly provide enough evidence for the events that happened for 20 to 50 years, which surely have hampered the entire investigating process. Therefore, the MND has readjusted the process and given priority to review cases with solid evidence. Totally 157 cases were reviewed and paid NT\$ 21,715,000 in compensation.

4. People's Appeals

(1). The MND's "Appeal and Petition Committee" is specifically responsible for dealing with appeals which might be made by people due to administrative negligence or inappropriate administrative penalties. The purposes of the procedure are to ensure the legal enforcement of public rights, and to protect both the rights of servicemen and the people.

(2). In compliance with the new "Appeal Law," the "Proceeding Guidelines of Examination, Description and Debate for the Appeal and Petition Committee" is hereby formulated by the MND to serve as the guiding principle of various appeal process. Additionally, in order to enhance the justice, objectivity and stringency of the lawsuit procedure, half of the members of the MND's "Appeal and Petition Committee" are scholars, experts and professionals from outside of the MND.

(3). From July 2000 to June 2002, the committee has dealt with 331 cases. Among them, 80 cases were rejected, 106 cases were ignored, 63 cases were either retried, and another 56 cases were either transferred or withdrawn. (Table 7-1)

(4). The general public is welcome to visit the website of the MND for information related to the appeals, and find the verdicts of the withdrawal

Table 7-1 People's Appeal Cases from 2000 to 2002

Category	Rejected	Ignored	Cancellation of Penalties	Transferred and Withdrawn	Total	Percentage
Pension and Allowances	14	33	21	12	79	24%
Seniority Counting and Retirement Request	21	16	14	8	59	18%
Military Dependents Quarters	17	13	14	2	46	14%
Bereavement Fund and Insurance Fund Request	8	7	7	3	25	7%
Cases of Punishment, Dismiss and Rehabilitation	6	3	3	3	15	5%
Military Service	1	6	3	4	14	4%
Promotion	5	3	6	0	14	4%
Land Compensation Fund	0	10	0	0	10	3%
Compensation for Damage and Losses	0	5	0	0	5	2%
Others	8	21	11	24	64	19%
Sub-total	80	116	79	56	331	100%

Source of Duration: July 1, 2000-June 30, 2002

administrative penalties announced by the Appeal and Petition Committee from the MND's communiques. In the future, the MND will post the data of appeals on the internet to improve the quality of inquiry service and provide more information.

5. National Compensation

To carry through the goal of "protecting the people's rights" as stipulated in "National Compensation Law," the MND, the GHQs and the commands of each branch (including the Army, the Navy, the Air Force, Combined Logistics Command, Reserve Command and Military Police Command) have established "National Compensation Deliberative Committee" to deal with national compensation cases. The MND has also enacted Procedure for National Compensation Issues to standardize the procedure of the compensation committees of various echelons and therefore to protect people's interests. From July 2000 to June 2002, the MND has

received 100 cases of requesting national compensation, of which 15 cases were concluded and has paid NT\$ 37,615,346 in compensation. Another 51 cases were denied, 3 cases were withdrawn by the applicants, 15 cases were given the verdict of the defendant, 3 cases were file closed, 6 cases are in the court process of deliberation, and 7 cases are still being handled by National Compensation Deliberative Committee.

6. Resolving the Problems of Obsolete Minefields

To follow the global trend of zero-mine, and to release and open the battlefields on offshore islands to tourism without impact on national security, the MND has radically reviewed and surveyed the minefields that have no tactical value or already been released control. Furthermore, the works of mine clearing have pursued outsource contractors, and the results are as follows:

- (1). Stage one: Clearing the obsolete mines of pile 6th at West Pu-tou Village (near Lee Kwan-chien Temple) in Quemoy by May 1998.
- (2). Stage two: Clearing the five piles of the obsolete mines at West Pu-tou Village, and two abandoned minefields, of which one at Shuan-ru Mountain and the other at Ho-pan Village, Quemoy by June 1999.
- (3). Stage three: Clearing the nine abandoned minefields in Quemoy from June 1st, 2000 to April 30th, 2001.

The clearance of landmines has already been done so that the goal of zero mine has been reached, and the people's safety has further protected.

III. Vision

In consideration of the changes through the interval of space and time, the MND has been taking steps to review the related regulations for protecting people's rights on the principle of ruling and compensating by law. Furthermore, in order to meet people's needs and win their approval and support, the MND has enhanced the justice, objectivity and stringency of the suit proceeding so as to show its attention on the preservation of human rights.

Providing Service to the People.

I. Joining Efforts to Maintain Social Security

1. Pursuant to national laws, regulations as well as agreements between the Military Police (MP) and the governmental police, the MND, in consideration of factors like political status and local situation, will join efforts with the police force to maintain social order and security on the principle of “prevention from social unrest before its outbreak, preemptive control of unstable situation and elimination of possibility of further turbulence.”

2. Generally speaking, the MP is responsible for handling military-related affairs on its role to maintain social security. The MP will still join efforts with security, intelligence, and investigation agencies or organizations so as to purify its internal mechanism, prevent and investigate civil criminal cases, and eliminate public hazards that may threaten the social security.

3. In order to maintain social order and tranquility, the MP has assisted the police force, from 2000 to 2001, to investigate 989 criminal cases, arrest 2,195 criminals, capture 663 deserters from the military, detain 192 gangsters, crack down 149 cases of stowaways from mainland China, seize 265 stowaways, hunt down 75 guns and 533 bullets, inspect 560 cases of drug smuggling (in which consisting of heroin 425.24 grams, amphetamine 13,753.78 grams, and marijuana 35.33 grams.)

II. Disaster Relief and Rescue

Even though combat readiness and military training are major undertakings of the military, the ROC Armed Forces, based on “the Calamity Prevention and Rescue Law,” will actively dispatch its forces to assist in relief and rescue efforts when a severe disaster erupts. From July 2000 to June 2002, the ROC Armed Forces has assisted in many rescue operations, in-



The Participation of the ROC Armed Forces in Disaster Relief Efforts

cluding disasters caused by Xangsane, Tami, Toraji and Nari typhoons; the oil spill caused by freighter "Amorgos" in Kenting region; the forest fires in Lishan and Mountain Shiue; the collapse of Kaoshiung-Pingtung Bridge; the crash a Singapore Airlines jumbo jet in Taoyuan, the crash of the China Airlines Jumbo Jet in Penghu, etc. There were over 490,000 personnel, 1,000 aircraft sorties, 5,900 ship sorties, 17,000 vehicles, and 2,100 sets of machinery, tools and water pumps involved in the relief and rescue operations (including emergent requisition of civil assets). (As Table 7-2)

Loving people and assisting people in distress are natures of the ROC Armed Forces. On the premise of no harm to combat readiness, the ROC Armed Forces will actively provide aids and take part in relief and rescue operations at short notice wherever the location is. The ROC Armed Forces will not only provide sufficient manpower, machinery and tools, but also cooperated with local governments to integrate the resources of military and civilian for rescuing victims, clearing mud and rocks, removing garbage,

Table 7-2
Statistics of Rescue Efforts Conducted by the ROC Armed Forces
from 2000 to 2002

Category		Typhoon Blis	The Collapse of K-P Bridge	Crash of Singapore Airline	Typhoon Xangsane	The Oil Spill Caused by Amorgos	Lishan Forest Fire	Mt. Shive Forest Fire	Typhoon Chebi	Typhoon Tami	Typhoon Toraji	Typhoon Nari	Typhoon Lekima	3.31 Earthquake	Lishan Forest Fire	Crash of China Airline
Aircraft (Sortie)	Aircraft (Sortie)	20	30		11		3	3			716	54			53	396
	Ship (Sortie)	4	4		31					35	10	90				5,735
	Vehicles	1,882	95	10	3,562	338			630	1,176	2,365	4,251	12	8		2,490
	Personnel	55,021	600	937	67,373	8,337	59	31	13,074	19,461	56,181	112,236	286	173	1,763	156,275
Sterilizing Area (Square Meter)	170.9			58.8						136.3	2,217.9	1,426				
Personnel Evacuated		4									450	3,242	1,581			
Sandbag Stacked (Bag)					28,760						1,500	25,981	30,250	7,000		
Garbage Disposed (Vehicles)	4,349			30,392	326.5 (oil 1s lick)				6,436	3,978	9,275.3	56,527				
Civil Residence Cleaned(Household)				3,969					25	3,819	8,950	4,545				
Road and Sewer Cleared (Km)	1,253.8			1,236.1					276.9	318.4	692.8	710.4				

Source of Duration : July 1, 2000-June 30, 2002

cleaning streets, and maintaining public facilities and transportation systems. Obviously, the Armed Forces will do its best to assist in relief and rescue operations to show its solid intention to protect the people and the nation.

III. Rescuing People in Distress

In July 2000, the "Search and Rescue Coordination Center of the Armed Forces" was incorporated into the integrated system of "National Search and Rescue Command Center of the Executive Yuan" for fusing authorities, controlling distress situation, and utilizing limited resources so as to effectively conduct rescue operations at a very short notice. Based on the International Agreement of Search and Rescue at Sea, the Standard of International Civil Aviation Organization (ICAO) and the notion of "Search & Rescue Sans Frontiere and Humanitarianism," the center has also joined efforts with "Coast Guard Administration of the Executive Yuan," "National Fire

Administration and National Police Administration of the Ministry of the Interior” to assist in search and rescue (SAR) operations within Taipei Flight Information Region (FIR) set by the ICAO. Not only is the center in charge of emergent medical evacuations for military personnel and civilian in air and maritime disasters within the Taiwan area (Taiwan, Penghu, Quemoy and Mastu), but also links with rescue coordination centers (RCC) of foreign countries in the vicinity to coordinate rescue and relief operations with each other.

From July 2000 to June 2002, there were about 27,000 military personnel, 500 aircraft sorties and approximate 50 ship sorties involved in rescue work. (As Table 7-3)

IV.Supporting Epidemic Prevention

With regard to the epidemic prevention, the ROC Armed Forces pay primary attention to self-protection and environment sanitation in the barracks. The ROC Armed Forces also assists local governments in cleaning up the

Table 7-3
Statistics of Calamity Rescue Efforts Conducted by the ROC Armed Forces from 2000 to 2002

Category		Maritime SAR	Mountain Disaster	Medical Evacuation	Disaster Rescue	Rescue Drill	Total
Number		129	25	106	76	1	337
Assigned	Aircraft (Sortie)	60	16	81	389	4	550
	Ship (Sortie)	54				1	55
	Personnel	219	44	31	27,248		27,542
People Evacuated		33	8	160	1,441		1,642
Material Shipped (Ton)					59,772		59,772

Source of Duration: July 1, 2000-June 30, 2002

environment so as to prevent epidemics

In order to protect the rescue forces and the victims from epidemics caused by natural disasters (such as typhoons, floods, earthquakes, etc.), the ROC Armed Forces will evaluate the severity of disasters in order to organize adequate sanitation inspection teams, and send such teams to disaster areas to assist in sanitary works and prevent epidemics. These teams will also inspect the sanitation of accommodation and drinking water, give advice for further improvement, assist in disinfectant spraying and provide the victims with other sanitary equipment to enhance their immunity against epidemics.

If an outbreak of epidemic occurs in any region, local military medical (or sanitary) units are demanded to instantly report to the Medical Bureau of the MND and regional sanitary organizations so as to properly control such

Figure 7-1 Procedures of Investigating Epidemics by the ROC Armed Forces

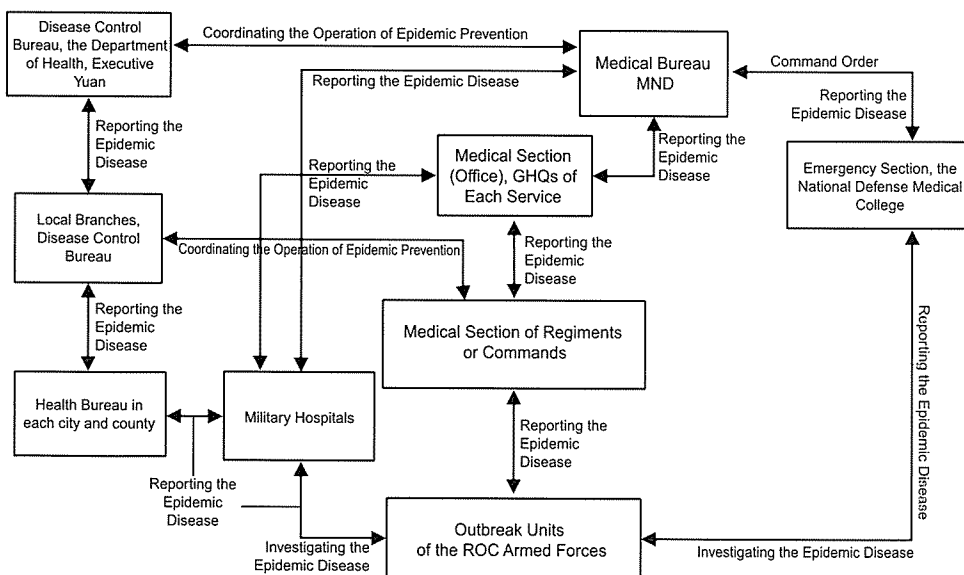

Source from "The Procedure of Investigating Epidemics (Including Food Poison) by the Armed Forces" Issued by the Ministry of National Defence on August 13, 2001.

situation. At the same time, the responsible military medical units will execute investigation and management procedures of emergency epidemic situation (Figure 7-1) in accordance with “the Procedures of Investigation and Management of Contingent Epidemic (including food poisoning) of the ROC Armed Forces” so as to have such situation under control, prevent such epidemic from spreading, and protect the health of military personnel. Besides, the responsible military medical units will conduct operations like evacuation of patients and virus carriers to hospitals, quarantine and treatment, distribution of preventive medicine, cleaning up the environment and the waste, examination of water, and spraying disinfectant. From July 2000 to June 2002, the ROC Armed Forces has participated in the every epidemic prevention operation of Xangsane, Willis, Trami, Torahi and Nari typhoons. There were totally 3,563 military personnel and 1,426 medical personnel being employed, disinfectant spraying of an area of 4,011 hectares being accomplished.

V. Promotion of Amity between the ROC Armed Forces and the People

1. Holding Family Reunions

In view of establishing good interaction and relieving doubts about military service, military units will hold family reunions and other social activities for families of conscripts so as to help them realize the importance of training and mission to protect the nation and its people, and convince them that the life of their children in service will be taken great care of. Through such interaction and communication in a cordial, warm and sincere way, families of conscripts will be comforted because they know the actual status of their children, and these conscripts will be further established cohesion in their respective units.

Basic military training centers (BMTC), military education units, and

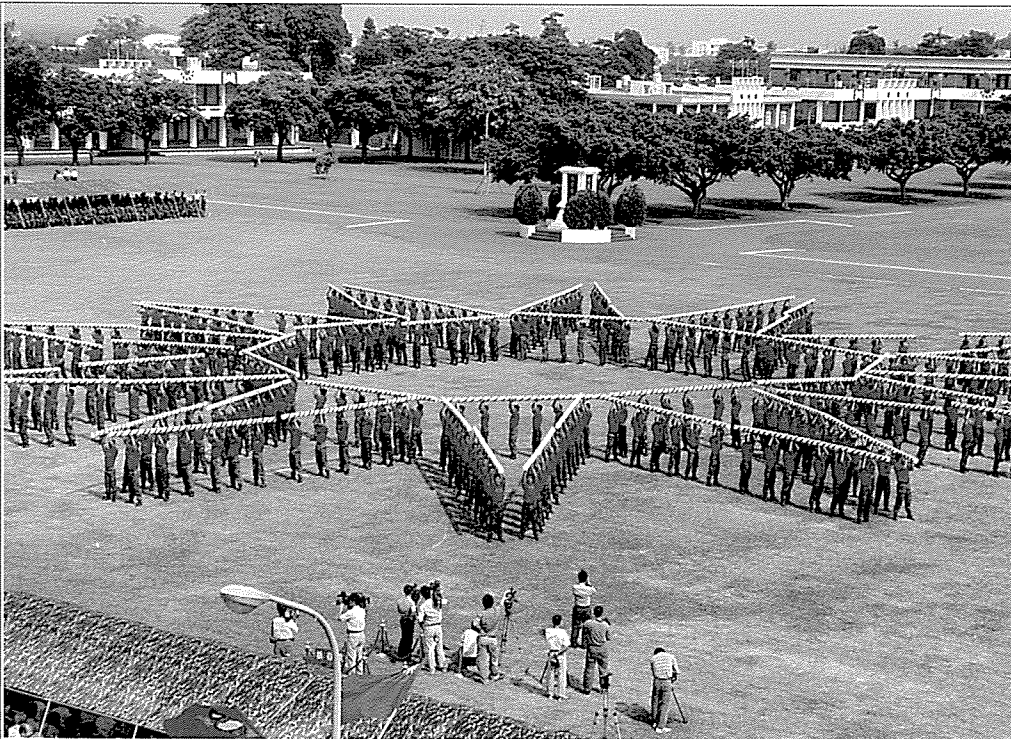

Parade of the ROC Marine Corps in Family Reunion

forces stationed in Taiwan Proper and offshore islands will offer reunions and social activities for families of conscripts after thorough consideration of their respective tasks and special occasions like major festivals, celebration of birth of the units, birthdays, and the opening days of camps. Additionally, in order to make the public understand the MND's efforts in military build-up and combat readiness and to promote sound relationships between the military and the public, various echelons of the ROC Armed Forces hold open sessions and parties in their barracks on festivals and ceremonies. Military dependents, local conscription agencies, local administrators and representatives are all invited to the scene. According to the statistics, there are 2,166 family reunions held by units of the ROC

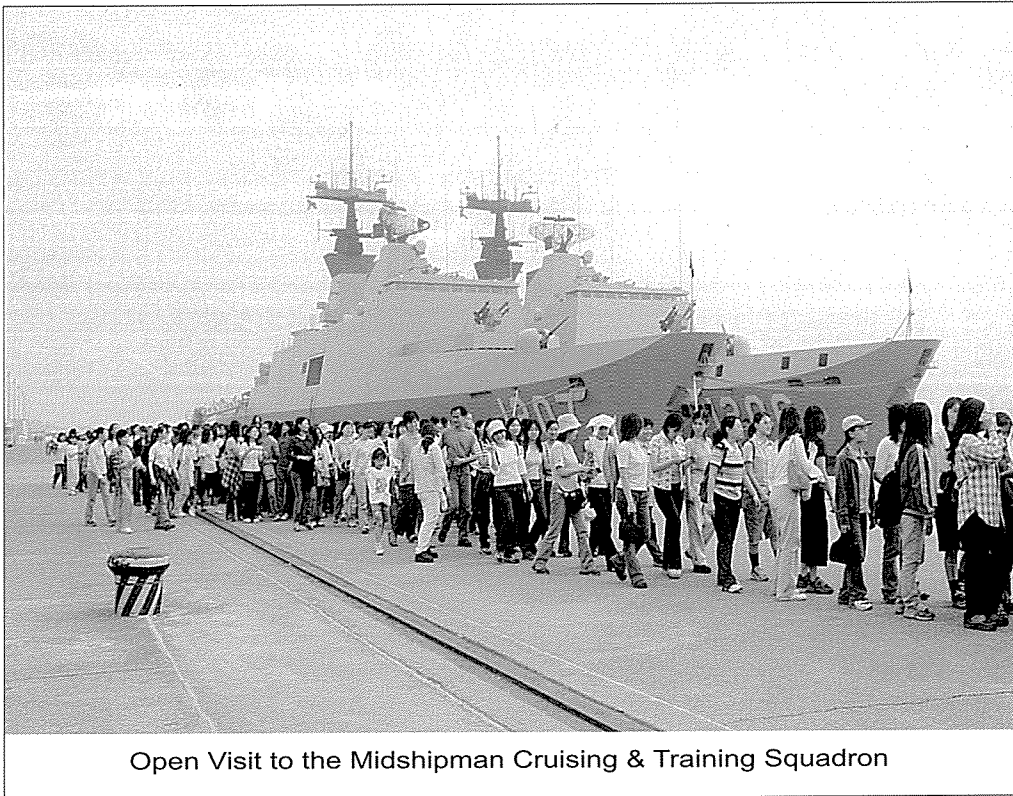

Open Visit to the Midshipman Cruising & Training Squadron

Armed Forces in 2001.

2. Promotion of Friendship

In order to promote friendship and military exchange between friendly countries, “the Fleet of Friendship” of the Navy in 2001 has paid port calls on eight countries, including the Republic of Palau, Guatemala, Saint Vincent, Saint Christopher, Dominican Republic, Belize, Honduras and Marshall Islands. The entire voyage in 2001 was 24,273 nautical miles. As for “the Fleet of Friendship” of the Navy in 2002, it has paid port calls on six countries, including the Republic of Nauru, Tuvalu, Solomon Islands, the Republic of Palau, Indonesia, Singapore, cruised around Nansha Islands, and visited the garrison forces in Ita Aba Islands. The entire voyage in

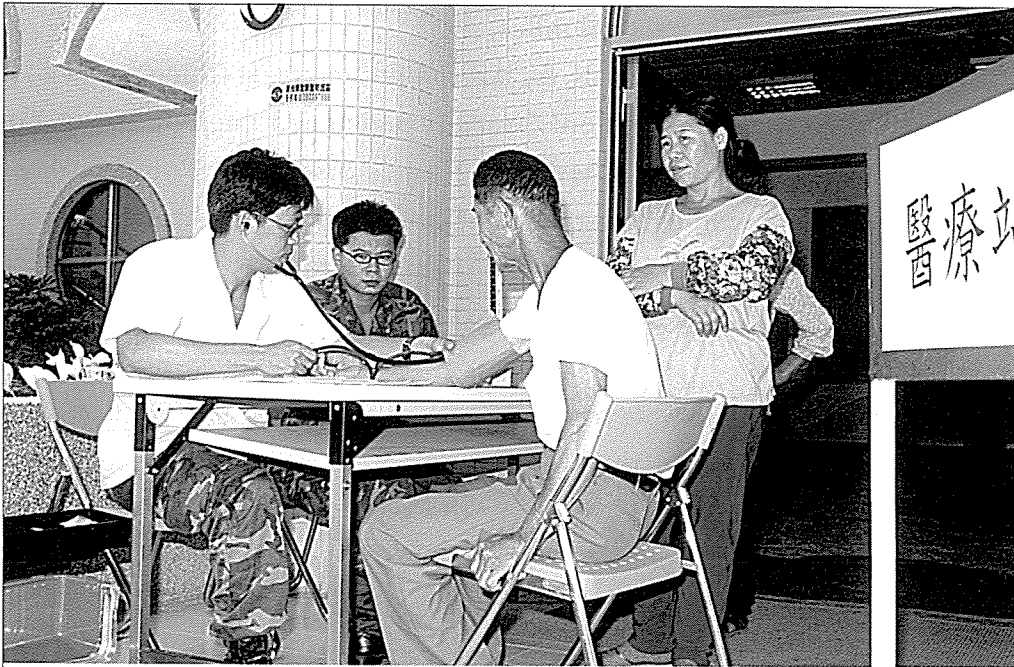

Loving-people and Protecting-people are Glorious Military Traditions

2002 was about 11,000 nautical miles.

During the overseas port calls, local residents, overseas Chinese and government of each country not only warmly welcomed the ROC Navy, but also were deeply impressed with the Navy's discipline. Through these journeys, sailors become more proficient in operating skills, and the Navy's ability to conduct blue water operations is also proved.

VI. Vision

To maintain the honorable traditions of loving the people and providing loyal service to the people, the ROC Armed Forces will always take the initiative to provide timely assistance to those people in need. Affairs like social security, disaster relief, personnel evacuation, epidemic prevention, etc, will be properly managed in a timely fashion. Additionally, through interactions, the ROC Armed Forces and the people not only will raise the relationship and cohesion in between, but also join hand-in-hand to achieve the goal of all-out defense.